



हुगली कोचीन शिपयार्ड लिमिटेड  
(भारत सरकार का उद्यम)  
**HOOGHLY COCHIN SHIPYARD LIMITED**  
(A Govt. of India Enterprise)



भारत सरकार  
ONE EARTH - ONE FAMILY - ONE FUTURE

Tender No: HCSL/OPS/SB/TEN/2024/052

Dt.- 13.12.2024

**NOTICE INVITING TENDER**

**Fabrication, Testing, Installation & Commissioning of Piping Systems for MPV Vessels (2200T) being constructed at Hooghly Cochin Shipyard Ltd, Nazirgunge unit, Howrah**

E-Sealed competitive tenders are invited on behalf of Hooghly Cochin Shipyard Limited (HCSL) from experienced vendors for the under mentioned work, so as to reach the undersigned on or before the date and time mentioned below. Please refer Scope of Work, General Terms and Conditions and Special Terms attached.

Tender No. & date	HCSL/OPS/SB/TEN/2024/052 Dt. 13-12-2024
Scope of work	Fabrication, Testing, Installation & Commissioning of Piping Systems for MPV Vessels (2200T) being constructed at Hooghly Cochin Shipyard Ltd, Nazirgunge unit, Howrah (Detailed specification is enclosed separately)
Type of Tender	Two Bid
Cost of Tender	Nil
Earnest Money to be deposit	Rs. 23,400/-
Last date & time of receipt of tender	03.01.2025 at 15:00 Hrs.
Date & time of opening of tender (Part – I)	03.01.2025 at 15:30 Hrs.
Tenure of contract	Refer Annexure-2, Clause 4.6
Officer - in - Charge (tender)	Name : Samrat Basu Designation : Manager (Mechanical) Email : <a href="mailto:samrat.basu@hooghlycsl.com">samrat.basu@hooghlycsl.com</a> Phone No. : +91 9094362621  Name : Johnson Grandage Designation : Deputy Manager (Mechanical) Email : <a href="mailto:johnson.g@hooghlycsl.com">johnson.g@hooghlycsl.com</a> Phone No. : +91 9562266770



Registered Office: Administrative Building, HCSL, Premises, Sanyal Base Road, P.O. Danesh Sarkin Lane, Nazirgunge, Howrah, West Bengal - 711 109.  
☎ +91 (033)-2688 8282 or contact@hooghlycsl.com | 🌐 www.hooghlycsl.com

Shipyard: Nazirgunge Unit, Sanyal Base Road, P.O. Danesh Sarkin Lane, P.S. Sankrail, Howrah, West Bengal - 711109.  
☎ +91 (033)-2955 8283

CIN - U35900WB2017GO223197 GSTIN - 19AATC136401ZD

Tender to be submitted by E-mail only. No hard copy quotation of the bid will be accepted.

Tender reference should be clearly indicated on the subject of the Mail.

Tenders should be submitted in two separate files as PART-I "TECHNO-COMMERCIAL" & PART-II "PRICE" (Password Protected) indicating the *tender number, due date of the tender and subject as in-line with the scope of supplies* in the Mail addressed to:

johnson.g@hooghlycsl.com / samrat.basu@hooghlycsl.com

The tender documents can be downloaded from HCSL/ CSL website <http://hooghlycsl.com/www.cochinshipyard.com>. The tender documents are available on above mentioned link. All corrigenda, addenda, amendments and clarifications to this tender will be hosted in the website [www.cochinshipyard.com](http://www.cochinshipyard.com) or <http://www.eprocure.gov.in> and not in the newspaper. Bidders shall keep themselves updated with all such developments till the last date and time of submission of tender.

**Tender administration:** Tender procedure/administration/evaluation including correspondences and awarding of contract will be done by M/s. Hooghly Cochin Shipyard Limited, Howrah, West Bengal.



*Samrat Basu*  
*Johnson G*  
**For Hooghly Cochin Shipyard Limited**

**Table of contents**

<b>Sl. No.</b>	<b>Description</b>	<b>Annexure</b>
1	Important Instruction to Bidders	Annexure-1
2	Technical Specification / Scope of Work	Annexure-2
3	Terms & conditions of enquiry	Annexure-3
4	General terms & conditions	Annexure-4
5	Special Terms & Conditions	Annexure-5
6	Techno-commercial check list	Annexure-6
7	Price bid format	Annexure-7A & 7 B
8	List of deviation	Annexure-8
9	Vendor details	Annexure-9
10	NEFT mandate form	Annexure-10
11	Form of Bank Guarantee towards EMD	Annexure-11
12	Format of bank guarantee towards SD	Annexure-12
13	Power of Attorney	Annexure-13
14	Form of self-declaration	Annexure-14
15	Form of legal cases	Annexure-15
16	Indemnity Bond	Annexure-16
17	Drawings	Annexure-17



*Dr. C. S. Srinivasan*  
Johnston Knowledge

**For Hooghly Cochin Shipyard Limited**

**IMPORTANT INSTRUCTION TO BIDDERS**

**Minimum Qualification Criteria for Participating in The Tender Will Be as Follows:**

- 1.1. The Bidder shall be a single firm having experience in various onboard fabrication, installation & commissioning of piping system in Shipyard/Marine application.
- 1.2. Experience as contractor in the successful completion of similar nature of works within the past 3 years ending last day of month previous to one in which applications are invited. (Satisfactory completion certificate along with GST Invoice and Work-order /Purchase Order from the Client for work done to be submitted along with bid). As part of financial capability evaluation vendor should have completed and submit the details of work experience in preceding 03 FY years (2021-22, 2022-23, 2023-24) of similar nature of works as follows:

**01 (one) work order of value at least Rs. 10.40 lakhs in past 3 FY's**

OR

**02 (Two) work orders of value at least Rs. 6.50 lakhs each in past 3 FY's**

OR

**03 (Three) work orders of value at least Rs. 5.20 lakhs each in past 3 FY's**

Similar nature means "Onboard fabrication, installation & commissioning of piping system in Shipyard/Marine application.

- 1.3. The work experience shall comprise of work having comparable nature to that of fabrication, installation & commissioning of piping system. If the experience claimed by the bidder is of no relevance with respect to fabrication, installation & commissioning of piping system, then such experience will not be considered for pre-qualification. Decision taken by HCSL in this regard will be final.

**Common Requirements from the Bidders:**

Following documents are required to be submitted by the bidders along with the Techno-commercial Bid (Part – I) submission:

- 1.4. The Bidder should enclose copy of statutory documents **PAN, GST registration certificate, Income tax returns for last three FY (2021-22, 2022-23, 2023-24) or of AY (2022-2023,2023-2024,2024-2025).**
- 1.5. Audited Balance sheets showing turnover, Profit & Loss account of the firm for the preceding 03 years, FY ((2021-22, 2022-23, 2023-24) should be submitted along with the application for



prequalification. **Net worth of the bidder must be positive as per the latest balance sheet. (MSE/NSIC may get exemptions as per prevailing Govt. norms).**

- 1.6. The average annual turnover of the bidder should be at least **Rs. 6.50 lakhs** during the last three preceding FY years ((2021-22, 2022-23, 2023-24).
- 1.7. Bidder shall not be under a declaration of ineligibility issued by Govt. of India/ State govt./ Public Sector Undertakings etc. The bidder shall not have been debarred / black listed by CSL/HCSL or by any of the Public Sector Undertaking or Government department etc.



*[Handwritten Signature]*

**For Hooghly Cochin Shipyard Limited**

**TECHNICAL SPECIFICATION / SCOPE OF WORK**

**Fabrication, Testing, Installation & Commissioning of Piping Systems for MPV Vessels (2200T) being constructed at Hooghly Cochin Shipyard Ltd, Nazirgunge unit, Howrah.**

**1. DESCRIPTION OF WORK**

- 1.1 This tender enquiry pertains to the awarding of contract for including partial material scope, fabrication, testing, installation & commissioning of piping system onboard (04 Systems) MPV 2200T vessels.
- 1.2 The work includes all Fabrication, Installation, pressure testing & Commissioning of piping system of the vessel in accordance with the indicative specifications and drawings enclosed, delivery schedule, HCSL - General Terms and Conditions in all respects.
- 1.3 The work is to be carried out at Hooghly Cochin Shipyard Ltd facility at Nazirgunge, Howrah.
- 1.4 **Bidder are requested to obtain clarifications, if any, and carefully study the documents and the scope of work of Contractor and HCSL, before submitting your offer.**
- 1.5 The contractors are advised to familiarize themselves with the site conditions before quoting.

**Four Piping Systems:**

**a) Sea Water Cooling System**

**b) Lubrication Oil System**

**c) Sanitary System**

**d) Oil Water separator System**

**2. ABOUT THE VESSELS**

2.1 Yard Nos. 004/22004

Main Particulars of vessel

Length overall - 78 Meter

Breadth molded- 16 meter

Scantling draft- 3.60 meter

2.2 Class: IRS

Class Notation :  $\Psi$  SUL, Indian River Sea Vessel -Type 4, Equipped for carriage of containers.  $\Psi$  IY General cargo vessel.





### **3. MODEL OF CONTRACTING**

- 3.1 Hooghly Cochin Shipyard Ltd (HCSL) proposes to offload fabrication, testing, installation & commissioning of piping system onboard Multipurpose Vessel.
- 3.2 All major pipes and flanges for the piping work will be provided by HCSL, along with relevant WPS/PQR and piping quality standards. **However, the items mentioned as “Scope of supply – Contractor scope relevant to each item / column” shall be supplied by the contractor only. (Refer Annexure- 2 , Enclosure A,B,C & D)**
- 3.3 The work shall be carried out based on the contract specification, Piping drawing, HCSL mentioned standards and Design drawings, up to the entire satisfaction of HCSL / Owner / Class Surveyor, and up to the completion of satisfactory sea trials of the vessel.

### **4. SCOPE OF WORK**

- 4.1 The scope of work under this tender involves:
  - 4.1.1 Complete fabrication, testing, installation & commissioning of piping system for MPV vessel, as per specifications and drawing (Flushing applicable for LO system only. Production drawings will be provided before commencement of work.
  - 4.1.2 All 32 NB and below size piping line will be fitted as per site condition or as instructed by officer in charge. If any bending required then contractor needs to bend the pipe as per site.
  - 4.1.3 Fabrication scope includes Cutting, Bending, Edge preparation of the pipe spools, Fit up survey, full welding, dry survey, acid pickling or galvanizing (for respective systems) and shop floor testing.
  - 4.1.4 Installation scope includes pipe & support installation onboard and including dry survey.
  - 4.1.5 Commissioning scope involves testing of pipe lines, commissioning assistance till completion of the vessel. Flushing of the LO pipe lines. Flushing machine to be arranged by contractor. Any consumable required for flushing including oil and sample testing of oil is in vendor scope.
  - 4.1.6 Galvanization including pickling of spools: Taking from yard, pickling & galvanization of spools and return of material to yard is in contractor scope. Including insurance
  - 4.1.6 Testing scope includes blanking of pipes and pressuring with required medium and offering surveys to the HCSL QC, Owner and Class.
  - 4.1.7 Pipe will be fabricated as per specification and the drawing provided by HCSL.
  - 4.1.8 Collection of material, material movement & accounting of the items.
  - 4.1.9 Fabrication, installation and testing of piping systems as per the details provided in list of pipe works. Fabrication & Installation drawing will be provided post award of work order.
  - 4.1.10 Survey presentation to Yard QC, Client and Class authorities as per yard practices and standards. Documents for the same may be accessed at HCSL. Copies of the same will be provided at the time of awarding contract.



- 4.1.11 Rectification of defects as per the comments from Yard QC, Client & Class authorities.
- 4.1.12 All tools and tackles, Welding machines, Flushing machine, Pressure testing pumps, pressure gauges for pressure testing, cutting tools, all consumables, production aids required for the work are under the scope of the subcontractor.
- 4.1.13 Arranging supporting blocks, jigs fixtures etc. for fabrication shall be to subcontractor scope.
- 4.1.14 Mobilization of entire labor / Workmanship (Skilled/ Semiskilled / Unskilled) required for the piping works.
- 4.1.15 The job includes drilling of holes with reference to all piping works and pipe clamps fixing,
- 4.1.16 Provision of required PPE and safety appliances to workmen,
- 4.1.17 Fabrication, fitment and testing of all piping systems as per the General Arrangement plan and piping drawings.
- 4.1.18 Equipment end connection under the scope of the contractor.
- 4.1.19 Testing of piping systems as per Class requirement.
- 4.1.20 Supply & fixing of all "U" clamp for pipe support with necessary nut, washers, rubber sheet are in contractor scope as per required sizes
- 4.1.21 Industrial LPG, CO2 gas any other required gases, Tig welding consumables, grinding wheel, gaskets all required consumables portable oven other machines & tools are under the scope of the contractor.
- 4.1.22 Welding of all other bulkhead/deck penetration piece iwo piping to Hull will be under firm scope.
- 4.1.23 For pipe installation all gaskets under contractor scope.
- 4.1.24 Removal and refit of pipes if required.
- 4.1.25 Hot dipped galvanization of CS pipes is in contractor scope.
- 4.1.26 The last spool shall be kept loose to adjust at site to prevent mismatch and onsite fouling issues. Drawings to be matched with onboard measurements.
- 4.1.27 The materials as mentioned are to be supplied and installed by the Piping contractor and the material test certificate (Mill Certificate) shall be submitted to HCSL for approval before delivering.
- 4.1.28 Welding machines, grinding machines, cutting machines and other equipment and tools required for the successful commissioning of piping system shall be positioned by the piping contractor only. Including wheels for grinding & cutting.

## **4.2. SCOPE OF HCSL**

- 4.2.1. Supply of drawings , materials & equipment as per enclosure A,B,C & D, Remaining items as per list (mentioned as scope of contractor) is in contractor scope.
- 4.2.2. Welding coil (consumable for Mig machine) & welding rods (6013 & 7018)





- 4.2.3. Quality Assurance Plan (QAP) and applicable Welding Procedure Specification (WPS) will be provided.
- 4.2.4. Yard facility like Place for work, Power Supply, Drinking Water, Crane & MHE Support, compressed Air (at available pressures)
- 4.2.5. Pipe ,Plates, Bolts, Valves, Nuts & Washer as mentioned in enclosure A,B,C,D
- 4.2.6. Angle / Channels for Pipe Support.
- 4.2.7. Required space for storage of materials inside the Yard (if required)
- 4.2.8. Staggering / scaffolding (as per requirement)

### **4.3. COMMON REQUIREMENTS**

4.3.1. The work shall be undertaken by only qualified welders of the contractor. Towards this, HCSL will provide the WPS and PQR. Welders will have to be qualified by Class IRS at Contractor's cost. **The welder qualification will be carried out at HCSL and the contractor would have to pay for the testing and certification charges.**

4.3.2. Work will be undertaken and inspected as per the quality standards provided by HCSL, and approved by Class and Owner of the vessels. The same may be seen prior bidding, if required. Copy of the standards will be provided while awarding contract.

4.3.3 The Bidder shall have sufficient TIG welding machine with pressure regulators for Argon gas, Helium Gas with flow meter.

4.3.4 Lifting tackles like Chain Pulley (up to 10 Ton), Lifting Belt, Wire rope and D Shackles / Bow Shackles is in contractor scope.

4.3.5 Housekeeping work at respective work areas.

4.3.6 Pressure Testing arrangement is in contractor scope as well as need to show the pressure test in front of HCSL QC and Class surveyor.

### **4.4. INSPECTION / TESTING/ QA AND QC**

4.4.1. Contractor to maintain the required dimensional accuracy and surface finish as per quality standards provided by HCSL

4.4.2. All test and Inspections shall be carried out as per approved QAP.

4.4.3. All works shall be as per strict compliance to weight control and approved HCSL drawings.

4.4.4. All correspondence with the Shipyard to be in English language. All documents and plans to be in English language and in metric units.



#### **4.5. SYSTEM SPECIFIC SCOPE**

**(MS Plate and CS pipe for system specific works shall be provided by yard)**

- 4.5.1. Supply and installation of Flexible hoses & Hose clamps for SW Cooling System and Spare Flexible hoses each size 1.5 Mtrs. (Approximate Dia of hoses 75 mm, 45 mm, 35 mm)
- 4.5.2. Pad plate for Stern Tube to be machined & fitted at designated location for SW System
- 4.5.3. Machining and welding of MS pad plate at designated location near stern tube area for Sanitary System.
- 4.5.4. Fabrication & Installation of 80NB/50NB deck scuppers Sanitary System.
- 4.5.5. Welding of MS pad / BHD Piece iwo Lub oil tank for LO system.
- 4.5.6. Fabrication, fitment, welding and dry survey of LO manifold -1 No (40NB).
- 4.5.7. For Lub oil piping acid pickling and flushing to be done, including flushing arrangement and sample testing, for another systems galvanization to be done (85 to 100 Micron).
- 4.5.8. Supply & installation of Con Reducer for various system.

#### **4.6 WORK COMPLETION SCHEDULE**

**Note:** These Days after issue of PO/LOI or intimation of site clearance by Project Manager/OIC for piping works.

System	Stage 1	Days for stage 1	Stage 2	Days for stage 2	Total Days
a. Sea Water Cooling System	Fabrication, dry survey, Galvanizing work	45	Erection, Installation, commissioning & Testing	15	60
b. Lubrication oil system	Fabrication, dry survey, pressure testing, acid picking and flushing work	15	Erection, Installation, pressure testing, commissioning & Trial run	15	30
c. Sanitary System	Fabrication, dry survey, Galvanizing work	45	Erection, Installation, commissioning & Testing	20	65
d. Oil Water separator System	Fabrication, dry survey, Galvanizing work	30	Erection, Installation, commissioning & Testing	15	45



SW cooling system						
S#	ITEM	SIZE & SCH	MATERIAL	Qty	UOM	Scope of Supply
<b>Carbon Steel Pipes</b>						
1	Pipe	65NB SCH 80	SMLS Carbon Steel ASTM A106 Gr.B	12	Mtr	HCSL YARD
2	Pipe	32NB SCH 80	SMLS Carbon Steel ASTM A106 Gr.B	60	Mtr	
3	Pipe	25NB SCH 80	SMLS Carbon Steel ASTM A106 Gr.B	1	Mtr	
4	Pipe	15NB SCH 80	SMLS Carbon Steel ASTM A106 Gr.B	1	Mtr	
<b>*SMLS- Seamless</b>				<b>Total (Pipes)</b>	<b>74</b>	<b>Mtr</b>
<b>Flat Face Flanges</b>						
5	Flat Face Flanges	65 NB, PN10	IS2062 Gr.A, CS Welded EN 1092-1 Type 1 FF FLG	12	Nos.	HCSL YARD
6	Flat Face Flanges	25 NB, PN10	IS2062 Gr.A, CS Welded EN 1092-1 Type 1 FF FLG	2	Nos.	
<b>Valves &amp; Fasteners for Main Pipe</b>						
7	SDNR Valve	65 NB	C.I /G.M	2	Nos.	HCSL YARD
8	SDSL Valve	15 NB	G.M	2	Nos.	
9	SDNR Valve	32 NB	C.I /G.M	2	Nos.	
10	SDSL Valve	32 NB	C.I /G.M	2	Nos.	
11	SDSL Valve	65NB	C.I /G.M	2	Nos.	
12	SDNR Valve OBD RT	32 NB	G.M	4	Nos.	
13	Nuts And Bolts With Washer	Respect to pipe & flange size	MS, Electroplated	As per requirement (Except for pipe supports)		HCSL YARD
14	Equal Angle	Respect to pipe size	MS	As per requirement (For pipe supports fab)		HCSL YARD
<b>Other Misc.</b>						
1	Elbow	65NB SCH 80	CS Butt Weld LR 80 SCH 65NB 90deg	12	Nos.	VENDOR SCOPE
2	Concentric Reducer	65 x 25	MS Galvanised Pipe Yard Scope	2	Nos.	
3	U-Clamp (with Nuts And Bolts With Washer for pipe supports)	As per respective pipe size	GI	As per requirement for every support		
4	Gasket	As per requirement	PN10 DIN 2t Aramid Fiber Outer CIR GSK On CS Pipe For Gen Use	As per requirement		
5	Rubber pad for supports	As per requirement	Neoprene Rubber	As per requirement		
6	Nuts And Bolts With Washer for pipe supports	As per requirement		As per requirement		

Sanitary system							
S#	ITEM	SIZE & SCH	MATERIAL	Qty	UOM	Scope of Supply	
<b>Seamless black MS Pipes</b>							
1	Pipe	50NB SCH 40	ERW PIPE HEAVY {C CLASS}, GI	19	Mtr	HCSL YARD	
2	Pipe	80NB SCH 40	ERW PIPE HEAVY {C CLASS}, GI	3	Mtr		
3	Pipe	100NB SCH 40	ERW PIPE HEAVY {C CLASS}, GI	15	Mtr		
<b>Total (CS Pipes)</b>				<b>37</b>	<b>Mtr</b>		
<b>Valves &amp; Angle for Main Pipe</b>							
4	SDSL Valve	32 NB	C.I /G.M	2	Nos.	HCSL YARD	
5	SDNR Valve	32 NB	C.I /G.M	1	No.		
6	SDSL Valve	50 NB	C.I /G.M	7	Nos.		
7	SDNR Valve	50 NB	C.I /G.M	1	No.		
8	SDSL Valve	100 NB	C.I /G.M	1	No.		
9	SDSL Valve	65 NB	C.I /G.M	1	No.		
10	STORM VALVE	50 NB	G.M	1	No.		
11	STORM VALVE	100 NB	G.M	1	No.		
12	Equal Angle	Respect to pipe size	MS	As per requirement (For pipe supports fab)			
<b>Flat Face Flanges</b>							
1	Flat Face Flanges	50 NB, PN10	IS2062 Gr.A, CS Welded EN 1092-1 Type 1 FF FLG	42	Nos.		VENDOR SCOPE
2	Flat Face Flanges	80 NB, PN10	IS2062 Gr.A, CS Welded EN 1092-1 Type 1 FF FLG	10	Nos.		
3	Flat Face Flanges	100 NB, PN10	IS2062 Gr.A, CS Welded EN 1092-1 Type 1 FF FLG	32	Nos.		
<b>Other Misc.</b>							
1	Elbow 45 deg LR	50 NB	GI	14	Nos.	VENDOR SCOPE	
2	Elbow 45 deg LR	100 NB	GI	4	Nos.		
3	Elbow 90 deg LR	50 NB	GI	15	Nos.		
4	Elbow 90 deg LR	100 NB	GI	8	Nos.		
5	Pipe Sleeve	65 NB	GI	22	Nos.		
6	Pipe Sleeve	125 NB	GI	13	Nos.		
7	Deck Scupper	80 x 50	MS Galvanised	10	Nos.		
8	Concentric Reducer	80 x 50	MS Galvanised Pipe Yard Scope	1	No.		
9	U-Clamp (with Nuts And Bolts With Washer for pipe supports)	As per respective pipe size	GI	As per requirement for every pipe support			
10	Nuts And Bolts With Washer	Respect to pipe & flange size	MS, Electroplated	As per requirement for both pipe joints and supports			



11	Gasket	As per requirement	PN10 DIN 2t Aramid Fiber Outer CIR GSK On CS Pipe For Gen Use	As per requirement		VENDOR SCOPE
12	Rubber pad for supports	As per requirement	Neoprene Rubber	As per requirement		
13	FO Manifold	To be fab as per drg	MS Plate will only be provided by yard for Fab.)	1	No.	

Enclosure C

Lub oil system						
S#	ITEM	SIZE & SCH	MATERIAL	Qty	UOM	Supply
<b>Seamless black MS Pipes</b>						
1	Pipe	25NB SCH 40	SEAMLESS BLACK MS	20	Mtr	HCSL YARD
2	Pipe	10NB SCH 40	SEAMLESS BLACK MS	4	Mtr	
Total (Pipes)				24	Mtr	
<b>Flat Face Flanges</b>						
3	Flat Face Flanges	25 NB, PN6	IS2062 Gr.A, CS Welded EN 1092-1 Type 1 FF FLG	22	Nos.	HCSL YARD
4	Flat Face Flanges	10 NB, PN6	IS2062 Gr.A, CS Welded EN 1092-1 Type 1 FF FLG	8	Nos.	
<b>Valves &amp; Fastners for Main Pipe</b>						
5	SDSL Valve	25 NB	C.I /G.M	6	Nos.	HCSL YARD
6	PR Valve	10 NB	C.I /G.M	5	Nos.	
7	Ball Valve	25 NB	C.I /G.M	1	No.	
8	Ball Valve	10 NB	C.I /G.M	5	Nos.	
9	Nuts And Bolts With Washer	Respect to pipe & flange size	MS, Electroplated	As per requirement (Except for pipe supports)		HCSL YARD
10	Equal Angle	Respect to pipe size	MS	As per requirement (For pipe supports fab)		HCSL YARD
<b>Other Misc.</b>						
1	Elbow	65NB SCH 80	CS Butt Weld LR 80 SCH 65NB 90deg	12	Nos.	VENDOR SCOPE
2	Concentric Reducer	65 x 25	MS Galvanised Pipe Yard Scope	2	Nos.	
3	U-Clamp (with Nuts And Bolts With Washer for pipe supports)	As per respective pipe size	GI	As per requirement for every pipe support		
4	Gasket	As per requirement	Non asbestos aramid fiber oil gasket , non reactive to chemicals and oil, 2 or 3mm thick	As per requirement		
5	Rubber pad for supports	As per requirement	Neoprene Rubber	As per requirement		
6	FO Manifold	To be fab as per drg	MS Plate and CS Pipe only Yard Scope	1	No.	

OWS system						
S#	ITEM	SIZE & SCH	MATERIAL	Qty	UOM	Scope of Supply
<b>Seamless black MS Pipes</b>						
1	Pipe	15 NB SCH 40	SEAMLESS BLACK MS	30	Mtr	VENDOR SCOPE
2	Pipe	25 NB SCH 40	SEAMLESS BLACK MS	3	Mtr	
3	Pipe	32 NB SCH 40	SEAMLESS BLACK MS	18	Mtr	
<b>Total (Pipes)</b>				<b>37</b>	<b>Mtr</b>	
<b>Flat Face Flanges</b>						
4	Flat Face Flanges	15 NB, PN6	IS2062 Gr.A, CS Welded EN 1092-1 Type 1 FF FLG	38	Nos.	VENDOR SCOPE
5	Flat Face Flanges	25 NB, PN6	IS2062 Gr.A, CS Welded EN 1092-1 Type 1 FF FLG	4	Nos.	
6	Flat Face Flanges	32 NB, PN6	IS2062 Gr.A, CS Welded EN 1092-1 Type 1 FF FLG	18	Nos.	
<b>Valves &amp; Fastners for Main Pipe</b>						
7	Globe Valve	15 NB	C.I /G.M	7	Nos.	HCSL YARD
8	Globe Valve	15 NB	C.I /G.M (Class Approved)	1	No.	
9	Globe Valve	25 NB	C.I /G.M	1	No.	
10	Globe Valve	32 NB	C.I /G.M	1	No.	
11	NRV Valve	32 NB	C.I /G.M	1	No.	
12	Storm Valve	15 NB	C.I /G.M	1	No.	
13	Equal Angle	Respect to pipe size	MS	As per requirement (For pipe supports fab)		HCSL YARD
14	Pipe Sleeve	15 NB,25NB, 32 NB	CS	As per requirement		HCSL YARD
<b>Other Misc.</b>						
1	Concentric Reducer	80 x 50	MS Galvanised Pipe	1	No.	VENDOR SCOPE
2	U-Clamp (with Nuts And Bolts With Washer for pipe supports)	As per respective pipe size	GI	As per requirement for every pipe support		
3	Gasket	As per requirement	PN10 DIN 2t Aramid Fiber Outer CIR GSK On CS Pipe For Gen Use	As per requirement		
4	Y-Strainer	15 NB	Brass	1	No.	
5	Nuts And Bolts With Washer	Respect to pipe & flange size	MS, Electroplated	As per requirement for both pipe joints and supports		
6	Rubber pad for supports	As per requirement	Neoprene Rubber	As per requirement		



**TERMS & CONDITIONS**

1. Fabrication, installation, testing & commissioning of four piping system onboard for multipurpose vessels being constructed at Hooghly Cochin Shipyard Limited, Nazirgunge Unit, Howrah.

2. **METHOD OF AWARDING CONTRACT**

2.1. Contract will be concluded with bidder qualifying technically (including eligibility criteria), agreeing to commercial conditions and emerging as L1 as per Annexure-7 of this tender document.

2.2. Order will be placed on one bidder only.

2.3. If any contractor, to whom the work is awarded, is not performing as per HCSL work plan, HCSL officer in charge has the right to modify / cancel the scope of work or volume of work in WO/PO and allocate to another contractor/bidder as required. HCSL reserves the right to split the work / percentage of work to any number of bidders (up to H1) upon matching of L1 price.

3. **PLACE OF WORK**

**Place of fabrication, welding, Pressure testing, Commissioning:**

Hooghly Cochin Shipyard Limited  
131/1, Satyen Bose Rd, Nazirgunje,  
Guabaria, Mourigram, Howrah- 711109, India.

**Galvanisation or Acid Pickling at Vendor's workshop outside HCSL Yard.**

4. **WORK PLAN / WORK COMPLETION SCHEDULE**

4.1. Within days as per annexure-2 clause 4.6 for each stage

4.2. **Work on all four systems is to be mandatorily progressed simultaneously in line with yard priority.**

4.3. Associated Material positioning in scope of contractor, has to ensure that it should not withhold production.

4.4. HCSL shall indicate the master construction schedule of completion of the work of vessel after awarding the contract. The contractor in turn shall submit their detailed schedule of completion of the work, in consultation with the officer in-charge. The progress of work shall be made in tandem with the progress of completion of the vessel allowing sufficient time for other interface activities / works.

4.5. Yard has the right to change the schedules of the project in the interests of the company and the firm should be capable of adjusting the resources according to the instructions from the yard contact person.

4.6. Progress of work to be updated to officer in charge in requested format (MS Project /MS Excel/ MS Word) twice in a month/ as and when a review meeting is called for.



## 5. VALIDITY OF OFFER

The offer shall be valid for acceptance for a period of 60 days from the date of opening of the Part-I Techno-Commercial Bid.

## 6. VALIDITY OF CONTRACT

Once the contract is awarded, the price offered and mutually agreed shall remain firm till **completion of work** and no escalation in labour, transportation cost etc. shall be allowed by HCSL on whatsoever reason thereafter.

## 7. PAYMENT TERMS

Payment will be made for each system separately.

7.1. Payment will be made in **stages**:(Below percentage is of total contract value of vessel)

### SW cooling System

Sl. No	Payment Terms for <u>SW cooling System</u>	Percentage
1	Fabrication & required galvanizing of spools of full <b>SW Cooling System Piping Works</b>	40
2	Erection of full system including Pipe Supports	35
3	Dry survey & Press. Testing of full SW Cooling System	15
4	Commissioning of SW Piping System	5
5	Defect Liability Period	5
	Total	100

### Lub Oil System

Sl. No	Payment Terms for Lub Oil System	Percentage
1	Fabrication and dry survey of Lub oil pipe spool	30
2	Pressure testing of LO system pipe at shop floor	10
3	Acid pickling and flushing of LO system	10
4	Erection of LO system including Pipe Supports	25
5	Commissioning of LO Piping System	20
6	Defect Liability Period	5
	Total	100

### Sanitary System

Sl. No	Payment Terms for Sanitary System	Percentage
1	Fabrication & required galvanizing of spools of full <b>Sanitary System Piping Works</b>	40
2	Erection of full system including Pipe Supports	35
3	Dry survey & Testing of full Sanitary System	15
4	Commissioning of LO Piping System	5
5	Defect Liability Period	5
	Total	100



## OWS System

Sl. No	Payment Terms for Oily Water Separator System	Percentage
1	Fabrication & required galvanizing of spools of full <b>Oily Water Separator System</b>	40
2	Erection of full system including Pipe Supports	35
3	Dry survey & Testing of full OWS Cooling System	15
4	Commissioning of OWS System	5
5	Defect Liability Period	5
	Total	100

Deliverables: Completion of defect liability period and Nil liability certification by HCSL officer in-charge. **OR** upon submission of Performance Bank Guarantee of equivalent amount, valid till completion of defect liability period. (Refer Clause17 of Annexure-3)

7.1.1. Payment shall be made on the basis of certification by HCSL officer in-charge. Contractor shall submit work completion certificate issued by HCSL authority.

7.1.2. The payment will be made within 30 days from submission of invoice along with the work completion certificate.

7.1.3. All claims for payment for the work/ additional work (if any as per special instruction from OIC) shall be submitted by the contractor within one month of completion of work.

7.1.4. Payment will be made by RTGS/NEFT to the account of agency. The name of the bank, branch, A/C No., IFSC code & other particulars shall be furnished by the agency in the proforma of HCSL.

7.1.5. Above % payment of order value with applicable taxes will be released against original invoice subject to the full satisfaction and acceptance of work / items by Officer -In-Charge. Original tax invoice should contain GST number of both parties and submit in triplicate.

7.1.6. Statutory levies such as I.T, Contribution towards PF, ESI etc., shall be paid by contractor and documents as a proof to be submitted along with invoice.

7.1.7. The Contractor shall provide the minimum wage rate of the Central Govt. and submit the Bank account statement of the wage payment along with the bill;

7.1.8. Contractor shall indicate details such as PAN, GST. required for processing payment. HCSL reserves the right for the deduction of taxes and duties as applicable from the bill or invoice.

7.1.9. The firm must comply with statutory requirements, like ESI/EPF etc., and other labor laws/regulations in force and as amended from time to time.

7.1.10. **The contractor shall provide the minimum wage rate of the Central Government & submit the bank statement of wage payment along with the bill.**

7.2. Quantum of work indicated at Annexure-2 and Enclosure A, B, C & D is final, however additional works as per clause 8 of Annexure-3, also to be considered while quoting, actual quantum of work executed at site shall be considered for the payment purpose.

## **8. ADDITIONAL WORKS**

Additional works up to 5% growth of work on the piping works in terms to be envisaged and is to be undertaken without any additional price impact.

8.1. Any minor modifications, resulting from the change in statutory regulations prevailing at the time of final inspection of work by classification society, to be carried out by the contractor free of cost. In case of rework/modification /additional work, the same is to be discussed and clearance to be obtained from the Officer-In-Charge before commencement of the work.

8.2. Contractor shall carry out the complete work in accordance with shipyard's approved drawings. Any minor modifications from drawing or any other work or supply of material, which is not specified hereunder, but is considered incidental and essential for the successful completion of the job shall be carried out by the contractor without any additional charge.

8.3. Contractor shall execute, during or after completion of the work, any minor job connected with the work, that is considered necessary by shipyard and/or classification society.

## **9. GROWTH OF WORK**

HCSL shall be at liberty to place additional work to the extent of contract value at the same rate, terms and conditions of the contract within contractual period and bidder shall have to honor it. Such additional work shall be entrusted to the contractor through a separate Order to that effect or through an amendment to the Order. In any case, the contractor should not undertake any (additional) work beyond the Contractual period without prior intimation by the Officer in charge. This additional work is considered beyond the total order quantity. Unit inch dia. Rates for various sizes and material to be submitted by vendor with price bid.

## **10. GUARANTEE FOR THE MATERIAL TAKEN OUT FROM HCSL**

The successful bidder should furnish Indemnity Bond i.e **15% of total material cost for material taken out from HCSL (for galvanization etc) in the approved format of HCSL (Annexure-16)**

"All risk Insurance cover for "Material lying down at contractor premises during the work/till dispatch shall be covered under the scope of the piping Contractor only. The approximate cost of material to be insured will be intimated at the time of dispatch for outward." However, Transit insurance to and fro shall be borne by HCSL.

## **11. TAXES & DUTIES**

GST shall be applicable extra on the prescribed work. Bidders are requested to furnish the following details in the invoice/Bill.

- Applicable rate of GST/SAC Code
- Firms GST Reg. NO.
- Service accounting code (SAC) as prescribed by statutory authorities
- GST Registration Number of Hooghly Cochin Shipyard Limited is **19AAECH3640L1ZD**

12. **MSE/ NSIC BENEFITS (If and only if the certificate issued is in the relevant field)**

A. The following benefits are extended for all the firms who are registered with district industries center and come under the category of **Micro and Small Enterprises** holding a valid Entrepreneurs Memorandum (EM) Part ii certificate or Udyog Aadhaar Certificate. However, in order to avail the benefits as per public procurement policy for MSE's orders, 2012, all MSE bidders are required to declare their Udyog Aadhaar Memorandum (UAM) number in Central Public Procurement Portal (CPPP) compulsorily.

- Tender Forms Shall Be Issued Free of Cost.
- Payment of earnest money deposit (EMD) is exempted.

B. For all firms who are registered with National Small Industries Corporation (NSIC) and come under Micro and Small Enterprises holding a valid NSIC certificate, the below benefit also extended in addition to above.

Waiver of security deposit (SD) for the performance of the contract (5% of the order value by the way of bank guarantee till the supplies are completed), up to financial limit as mentioned in NSIC certificate.

C. This tender shall be based on MSE order dated 23<sup>rd</sup> march 2012, pertaining to public procurement policy.

D. MSE's quoting price band L1 + 15% (in the ascending order) may be awarded complete work, considering spirit of policy for enhancing the government procurement from MSE's.

E. Traders are exempted from the benefits from Public Procurement Policy, for MSEs Order, 2012. As mentioned in O.M. No. 5/2(2)/2021-E/P & G/Policy dated 02.07.2021, Retail and Wholesale traders can register on Udyam Registration Portal for the purpose of Priority Sector Lending (PSL) only.

13. **COST OF TENDER AND EMD (EARNEST MONEY DEPOSIT)**

- a) Cost of Tender: Nil
- b) Tenderers shall deposit an amount of **Rs.23,400/- (Rupees Twenty three thousand four hundred only)** as Earnest Money Deposit (EMD) along with the tender.
- c) The EMD can be remitted in the form of Demand Draft (DD) / Banker's Cheque / Fixed Deposit Receipt (FDR)/ Bank Guarantee drawn in favor of 'Hooghly Cochin Shipyard Ltd. payable at Kolkata and shall be valid for a period of 6 (Six) months from the due date of opening of Techno-commercial Bids from any Nationalized/ Scheduled Bank or paid online through e-gateway of -

**HOOGLY COCHIN SHIPYARD LIMITED  
STATE BANK OF INDIA  
COCHIN SHIPYARD BRANCH  
ACCOUNT NO: 37354232301  
IFSC CODE: SBIN0003229**

- d) EMD of bidders (unsuccessful during first stage i.e. technical evaluation etc.) shall be returned after declaration of result of first stage i.e. technical evaluation.



- e) EMD of bidders (unsuccessful after price bid opening) will be released after issuance of work order and its acceptance by the contractor to whom the work is awarded.
- f) EMD of the successful bidder will be refunded after remittance of the security deposit.
- g) EMD deposited with the Client will be forfeited,
  - (i) if a bidder withdraws or modifies his bid during the period of validity specified or
  - (ii) if the successful bidder fails within the time limit to sign the agreement document or fails to furnish the required security deposit.
  - (iii) Request for enhancement in the quoted rates or bringing in new conditions after tender opening or unnecessary delayed acceptance of the order / commencement of work / submission of Security Deposit.
- h) The relevant documents pertaining to the EMD should be enclosed with Techno-commercial Bid. TENDERS RECEIVED WITHOUT EMD WILL NOT BE CONSIDERED FOR FURTHER EVALUATION.

14. **SECURITY DEPOSIT/WARRANTY BANK GUARANTEE** (Not applicable if order value is less than 20 Lakhs)

The successful tenderer shall remit 5% of the value of the contract as security deposit within 07 days of receipt of the work order. This amount after adjusting the EMD may be remitted by way of demand draft or bank guarantee (in approved proforma of HCSL) from any of the scheduled banks, valid till the satisfactory completion of the entire work i.e. completion of sea trials. The Security Deposit will be released after satisfactory completion of the contract i.e. completion of sea trials of vessel and on certification of nil liability to HCSL by Officer-in charge.

15. **LIQUIDATED DAMAGES**

In case of delay in supply of ordered materials or execution of work beyond the stipulated completion period, which is not attributable to HCSL, supplier is to pay Liquidated Damages (and not by way of penalty) a sum equivalent to ½% (half percent) per week or part of the week of the total basic price of the contract value subject to a maximum of 10% of the total basic price of the contract value (Total basic price is the order value excluding freight, taxes, other charges etc.). Further GST will be applicable upon LD and the same also will be deducted along with LD. However, LD applicability is without prejudice to HCSL right to terminate contract for delayed delivery or other actions as per Risk Purchase clause.

16. **RISK PURCHASE**

If the contractor fails to commence the work in time, as per the terms in work order or violate any other terms & conditions of work order OR If the firm's performance is found not satisfactory with regard to the progress of work, quality, and time factor, labour dispute with their workers, poor safety record, contract shall be terminated with 7 day notice and no claim whatsoever will be entertained in this regard from the firm. HCSL shall have the following rights.

- a) To terminate the contract within 7 days of notice forfeiting the Security Deposit
- b) To initiate alternative arrangements at the risk and cost of the contractor.



## **17. DEFECT LIABILITY PERIOD**

The contractor has to guarantee the workmanship for a minimum period of 8 months or delivery whichever is the earlier from the date of successful completion of work, against defective workmanship. Respective % of the Contract value shall be released to the Contractor on completion of the Defect Liability Period. Any trouble or defect originating with the workmanship of any facilities installed arises at any time up to 8 months from the date when the work is successfully completed, and the CONTRACTOR is notified thereof, the CONTRACTOR shall at his own expense and as quickly as possible make such alteration / repairs and replacements as may be necessary to comply with the above guarantees and shall reimburse any costs and expenses incurred by HCSL in connection with such trouble or defect. If the contractor fails to take action as above as HCSL shall direct, HCSL shall be free to take corrective/alternative action at the contractor's cost and risk within a reasonable time.

## **18. FORCE MAJEURE**

18.1. Should failure in performance of the contract or part thereof arise from war insurrection, restraint imposed by government, act of legislature or other statutory authority or illegal strike, riot, legal lock-out, flood, fire, explosion, act of God or any inevitable or unforeseen event beyond human control which may be construed as reasonable ground for an extension of time, HCSL may allow such additional time as is mutually agreed to be justified by the circumstances of the case. The occurrence/cessation of force majeure situation is to be informed with documentary evidence within 15 days from the date of occurrence/cessation.

## **19. TERMINATION & LIMITATION OF LIABILITY**

19.1. This contract may be terminated upon the occurrence of any of the following events.

19.1.1. By agreement in writing of the parties hereto;

19.1.2. By the non-defaulting party, upon default by the other party, of any clauses of this contract, if not remedied within fifteen (15) days, or such longer time as may be agreed upon by the parties, after receipt of notice thereof in writing from the non-defaulting party.

19.1.3. By the other party, upon either party:

- (i) Making the assignment for the benefit of creditors, being adjudged a bankrupt or becoming insolvent; or
- (ii) Having a reasonable petition filed seeking its' dissolution or liquidation, not stayed or dismissed within sixty (60) days; or
- (iii) Ceasing to do business for any reason.

19.1.4. In cases where maximum limit of LD is reached and still the items are not delivered or service not executed.

19.1.5. For fraud and corruption or other unacceptable practices.

19.1.6. Upon expiry or termination of this Contract, neither party shall be discharged from any antecedent obligations or liabilities to the other party under this Contract unless otherwise agreed in writing.

19.2. HCSL may by notice in writing to supplier terminate the order after issuing due notice i.e. '7 days' notice period. HCSL shall be entitled to compensation for the loss limited to the order value.

19.3. Liability maximum that can be claimed by the supplier shall be limited to what is due to be and has been paid by HCSL for the material delivered /work done as per the payment milestones.

## **20. STORAGE OF MATERIAL AND EQUIPMENT**

20.1. The contractor shall arrange the storage of the materials/ equipment etc. if any, at a suitable location assigned by HCSL and shall ensure the safe and secure possession and handling of the items thus handed over to contractor. HCSL shall allot storage space within HCSL premises, if available.

20.2. As regards the equipment/ materials stored by him as above as also in use by him, HCSL will not be responsible for any damage, pilferage, accident that may take place during the course of execution of the work. It will be entirely his responsibility to keep all the equipment, materials etc., in safe custody as also hold them duly insured at his expense.

## **21. POWER OF ATTORNEY**

The tenderer(s) shall have to sign in each page of the tender documents with official stamp as a token of his acceptance of the conditions stated therein. The person signing the tender form on behalf of another or on behalf of a firm, shall enclose to the tender, a Power of Attorney or the said deed duly executed in his favor or the partnership deed giving him such power showing that, he has the authority to bind such other persons or the firm, as the case may be, in all matters pertaining to the contracts. If the Person so signing the tender, fails to enclose the said Power of Attorney, his tender shall be liable for being summarily rejected. The Power of Attorney shall be signed by all partners in the case of partnership concern, by the proprietor in the case of a proprietary concern, and by the person who by his signature can bind the company in the case of a Limited Company.

## **22. ARBITRATIONS**

22.1. Any disputes arising during the execution of the contract shall, in the first instance be settled by mutual discussions and negotiations. The results of such resolution of dispute shall be incorporated as an amendment to the contract, failing which the parties can resort to arbitration.

22.2. If any dispute, disagreement or question arising out of or relating to or in consequence of the contract, or to its fulfillment, or the validity of enforcement thereof, cannot be settled mutually or the settlement of which is not herein specifically provided for, then the dispute shall within thirty days from the date either party informs the other in writing that such disputes, disagreement exists, be referred to arbitration. The arbitrators shall be appointed and the arbitration proceedings shall be conducted in accordance with and subject to the Arbitration and Conciliation Act, 1996 (No. 26 of 1996) as amended from time to time and the decision of the Arbitrators shall be final and binding on the parties here to. The arbitration will be done by a Board comprising one officer nominated by each party, and a mutually agreed Umpire. Each party shall bear its own cost of preparing and presenting its case. The cost of arbitration shall be shared equally by the parties unless the award provides otherwise. The enforcement of the award shall be governed by the rules and procedures in force in the State in which it is to be executed. Performance under this Contract shall however, continue

during arbitration proceedings and no payment due or payable by the parties hereto shall be withheld unless any such payment is or forms a part of the subject matter of arbitration proceedings.

22.3. In case of disputes, the same will be subjected to the jurisdiction of courts at Kolkata, West Bengal, India only. Governing law should be Indian law and place and seat of arbitration is at Kolkata, West Bengal. Language of arbitration should be English.

### **23. LABOUR LICENSE**

The Agency has to take Labour License from the appropriate Authority for the said work under Contract Labour Regulation & Abolition Act 1970. Further the Agency has to apply for Form III to the Principal Employee with the intimation to the commencement of the work. While applying for FORM III the Agency has to submit PAN No, LIN No, registered Address and other information as desired by the Principal Employer. While Submitting the Bills The agency has to submit all the relevant documents to the HR Dept of HCSL for statutory Clearance of Bills.

### **24. LABOUR LAW & REGULATIONS**

**(Time to time amendments by Govt. to be strictly followed)**

24.1. The contractor shall undertake and execute the work with contract labour only after taking license from the appropriate authority under the contract labour (regulation & abolition) act 1970.

24.2. The contractor shall observe and comply with the provisions of all labour and industrial laws and enactments and shall comply with and implement the provisions of the factories act , 1948, employees provident funds at miscellaneous provisions act, 1952, employees state insurance act, payment of gratuity act, minimum wages act, payment of bonus act, contract labour (regulation and abolition) act and all other enactments as are applicable to his and his workmen employed by him.

24.3. All contract workmen, shall necessarily be insured under the ESI scheme and be made members of the EPF scheme from the day of their engagement as contract workmen in the company. All such insured contract workmen should carry with them their ESI identity card for verification by the authorities. No contract workmen without a valid ESI identity card for verification by the authorities will be permitted to work in the company.

24.4. The Contractor shall submit the labour reports/ returns as required by the company from time to time in respect of their workmen in standard format to the concerned contracting officer so as to enable the same to reach personnel department by the 5th of every month. Delayed submission of the same shall attract penal interest /damages at the rate as levied by the respective authorities under the relevant Acts.

24.5. The Contractor shall maintain the records viz. muster roll, acquittance roll with full details, account books etc., in original. These are required for inspection by the concerned authorities under each scheme.

24.6. If the Contractor fails to pay any contributions, charges or other amounts payable under any of the aforementioned provisions of law, HCSL shall deduct or adjust amounts equivalent to such contribution, charges or amounts from amount payable to him by HCSL, including any deposit or amounts payable against bills and make payments on his account to the appropriate authority. He

shall not be entitled to question or challenge such deductions, adjustments or payment made by HCSL.

24.7. Any other amount payable under any law or in respect of any person employed by the Contractor, if not paid by him, shall be deducted or adjusted by HCSL out of any amount payable to the Contractor including any Security Receipt and paid ever or withheld for payment by HCSL.

24.8. The Contractor shall be fully responsible for the conduct and discipline of the workmen employed by him in the Company premises. If such workmen commit any misconduct or criminal act inside the Company, the Contractor shall take appropriate action against such workmen. The contractor shall abide by the instructions/ guidelines issued by the Company for maintenance of discipline and good conduct among the workmen employed by him.

24.9. All person who are engaged for various works in HCSL either directly or through contractors, should produce the following documents prior to issuing their entry passes:

Aadhar/attested copy of Aadhar with photo and address particulars. **OR**

Police clearance certificate with photo and address particulars. (Police clearance certificate to the effect that the concerned person is staying in the area of jurisdiction of the certificate issuing police station and that the person is not involved in any criminal offences as per the records available therein.)

Application and declaration for enrolling under employee's provident fund and ESI Scheme.

24.10. Contractors are requested to familiarize themselves with the labour rules & regulations prevailing in HCSL including the labour wage pattern of contract labours.

## **25. SAFETY OF PERSONNEL AND FIRST AID**

25.1. The contractor shall be entirely responsible for the safety of all the personnel employed by him on the work. In this regard, he may adopt all the required safety measures and strictly comply with the safety regulations in force. Detailed information and references available with HSE department of HCSL.

25.2. The Contractor may arrange to suitably insure all his workmen/ other personnel in this regard. HCSL will not be responsible for any injury or illness to the Contractor's workmen/other personnel during execution of the works due to whatsoever reasons.

25.3. In this regard, the Contractor will have to fully indemnify HCSL against any claims made by his workmen/other personnel.

25.4. The Contractor shall provide and maintain so as to be readily accessible during all working hours, a first aid box with prescribed contents at every place where he employs contract labour for executing the works.

25.5. Occupational Health, Safety & Environmental Requirements: Contractor is deemed to comply with the occupational health, safety and environmental policy of the company.



## **26. IMS GUIDELINES**

26.1.HCSL implemented an Integrated Management System (IMS) consisting of Environmental Management system (EMS), Occupational Health and Safety Management System (OHSMS) and the Quality Management System (QMS) within the yard. As part of IMS, subcontractors shall comply with the following measures related to the Quality, Health, and Safety & Environment (QHSE) policy of HCSL.

26.1.1. Preventing occupational ill health and injuries.

26.1.2. Ensuring safe work sites.

26.1.3. Handling and disposal of Hazardous wastes safely.

26.1.4. Complying with statutory & regulatory and other requirements.

26.2. If any contractor failed to comply with or violated any clauses/requirements of occupational health, safety and environmental rules effective in the state, in their activities or at work sites and the same shall be exposed to the government or any competent authorities upon inspections, the contractor shall be solely responsible for all liabilities caused by his/her action and shall be responsible for paying the penalty and taking stipulated corrective actions insisted by the authorities within the specified time, at their own cost. Any liability to the company in this regard needs to be compensated by the contractor.

## **27. ELECTRICITY RULES & REGULATION**

27.1. The contractor shall adhere to the various rules in respect of electrical installation as per the Indian Electricity Rules and Regulations and Electrical Inspectorate Standards in order to make sure that men and materials are safe from hazards.

## **28. SUB CONTRACTING AND ASSIGNMENT**

28.1. Contractor shall neither assign nor transfer the Purchase Order/ Work Order nor shall any share or interest therein in any manner or degree be transferred or assigned by Contractor to a third party without prior consent in writing of HCSL.

28.2. Contractor shall not contract with any subcontractor and/or vendor without the prior written consent of HCSL. Such consent shall not relieve the Contractor from any of his responsibilities and liabilities under the Purchase Order/ Work Order. In addition, Contractor shall ensure that the terms and conditions of any such contract shall comply with and correspond to the terms and conditions of the Purchase Order/ Work Order.

## **29. INDEMNITY**

29.1.The firm shall indemnify HCSL and keep harmless against any or all claims, liabilities, damages, losses, costs, charges, expenses, proceedings and actions of any nature whatsoever made or instituted against HCSL directly or indirectly by reason of:

- a Any wrongful, incorrect, dishonest, criminal, fraudulent or negligent work, misfeasance, disregard of duties by personnel of the firm; and/or

b. Any theft, robbery, fraud or wrongful act or omission by personnel of the firm.

29.2. The service provider shall indemnify HCSL or its officers against any claims arising out of accidents or injuries to workmen or other persons or damage to other property which may arise during the execution of the contract or from breach of any Law or Regulation prior to delivery and acceptance of the items at HCSL.

29.3. Under no circumstances HCSL will be responsible for any statutory compliance related to Labor, Central/State Government if any.

### **30. OVERWRITING & CORRECTIONS**

Tenders shall be free from overwriting or erasures. Corrections and additions, if any, shall be duly attested and a separate list of such corrections shall be attached with the offer.

### **31. SECRECY CLAUSE**

31.1. The CONTRACTOR shall be responsible to ensure that all persons employed by them in the execution of any work in connection with this contract are aware of the provisions of the official secrets act 1923 and to comply with the same. The CONTRACTOR shall also ensure secrecy of design, construction, equipment and completion of the vessel. Any information provided to you under this contract is to be treated as strictly confidential and is not to be disclosed to any person or persons not concerned therewith.

31.2. All documents under this Contract transferred between the parties shall be treated as UNCLASSIFIED unless explicitly marked.

31.3. The CONTRACTOR shall ensure that their organization, suppliers/ installation agency/test and trials teams etc. shall not communicate for use in advertising, publicity, sales release or in any other medium, system details, photographs and reproduction of equipment and their fitment on board Navy/coast guard/private owner vessels except without written approval from the competent authority of HCSL.

### **32. DAMAGE OF MATERIALS / EQUIPMENTS**

The contractor will ensure that no damage is caused to the materials, due to negligence and / or any reason whatsoever by the contractor's man. The cost of damage will be suitably recovered from vendor's bills.

### **33. INDIVIDUALITY OF CONTRACT**

This Contract should be treated as an individual contract and should not be related with other orders with HCSL in respect of progress of work or payment.

34. Acknowledgement of the Purchase order/Work order by signing and returning a copy of same within 3 days is required once the order is placed to vendor. If acknowledgement is not received, it will be presumed as accepted.

For Hooghly Cochin Shipyard Limited



**GENERAL TERMS & CONDITIONS**

1. Specific resources required/employed for the job: The contractor shall deploy and submit details of resources (equipment and manpower) of adequate capacity and quantity to be specifically provided for subject works. Details to be submitted after award of order, prior start of work.
2. The contractor/bidder must have a site-in charge/ supervisor to execute work, with a minimum experience of 3 yrs. In similar works;
3. The Contractor shall provide the minimum wage rate as prescribed by the Central Govt. to their workmen/s.
4. The Contractor shall have to engage men on round the clock basis and also on Sundays and holidays, if required. Work has to be completed to the satisfaction of Hooghly Cochin Shipyard Engineers deputed for the job. The job should be completed at the time specified by the supervising Engineer for each stage of work.
5. The upper age limit of all workers and supervisors employed by the contractor and those contractors who do or supervise the job themselves shall be as per the prevailing rules of HCSL.
6. The work will be undertaken by only qualified welders of the contractor. Towards this, HCSL will provide the WPS and PQR. Welders will have to be qualified by Class by HCSL. **The subcontractor must pay for the welder qualification, testing and certification charges to HCSL on actuals. The contractor must retain the qualified welders till the completion of the project.**
7. Work will be undertaken and inspected as per the quality standards provided by HCSL, and approved by CLASS and Owner of the vessels.
8. Area and steel skids will be provided by HCSL, leveling of the skid will be undertaken by contractor to the satisfaction of HCSL QC. Required production aids shall be arranged by Contractors.
9. The contractor shall arrange to collect and clean up every day all waste, scraps, debris, etc. generated by the work men while working onboard the vessel and other locations and dispose the same suitably at his cost to the full satisfaction of HCSL. In case any failure on his part to comply with this requirement, HCSL will arrange the required cleaning entirely at the contractor's cost.
10. Assistant General Manager (P&P) or his authorized representative will be the Officer-in-charge of this Contract.
11. Material supplied by HCSL may not be in the required size and shape. These may be cut and prepared after proper nesting by the Contractor. Special care to be taken to reduce wastages. Shortage of any material (supplied by HCSL) arising out of excess wastages due to improper planning shall have to be made up by Contractor free of cost.
12. The contractor shall be responsible for any damage caused to the material supplied by HCSL. Compensation with penalty for damage or loss of the item will be recovered from the Contractor, in the event of loss or damage.

13. Any particulars/literature/information/certificates required by the Shipyard in connection with the work is to be forwarded free of cost.

14. All correspondence with the Shipyard to be in English language. All documents and plans to be in English language and in metric units.

15. Contractor to provide all personnel protective items like safety helmets, gloves, welding shields, goggles, leg guards, safety belts, boiler suit, safety shoes etc. to their employees.

16. The firm shall be solely responsible for the payment of wages, salaries and other legal dues of its personnel who are employed or deployed by it from time to time. The firm shall promptly pay all due salaries and wages to its personnel providing service. HCSL reserves the rights to ask the firm to submit satisfactory evidence of payment due, salaries etc. In any event, HCSL shall not be liable for any payments, dues, wages and salaries of the personnel deployed by the firm.

17. Necessary Insurance Coverage for the contractor's materials / equipment / vehicle including Third Party liability and for the workmen (covering Workmen's Compensation Act) engaged by the Contractor are to be taken at his cost. If any accident/injury occurs to any other persons/public due to proven negligence/non-adherence to relevant safety and other precautions on the part of Contractor/it's employees, the contractor shall remain liable to pay necessary compensation and other expense, as decided by appropriate authorities.

  
 **For Hooghly Cochin Shipyard**

**SPECIAL TERMS & CONDITIONS (TWO-BID SYSTEM)**

**1. MODE OF SUBMISSION OF TENDERS:**

- Tenders should be submitted in two separate files as **PART-I "TECHNO-COMMERCIAL"** & **PART-II "PRICE"** indicating the tender number, due date of the tender in the e-Mail and addressed to The Assistant General Manager (Materials), Hooghly Cochin Shipyard Limited, Nazirgunge Unit, Howrah. Tender to be submitted by Email only.
- Bidders are requested to submit the bid by e-mail (**Price part password protected**) to the following email addresses clearly mention the tender reference in the subject line for easy identification:

[johnson.g@hooghlycsl.com](mailto:johnson.g@hooghlycsl.com) / [samrat.basu@hooghlycsl.com](mailto:samrat.basu@hooghlycsl.com)

- While submitting the bid, bidders are requested to note that the e-mail ID starting with following words may probable be treated as spam, not always necessary-  
*info, support, admin, sales, customer support, helpdesk, mail, mail admin, billing, hello, careers.*

**2. TECHNO-COMMERCIAL PART SHOULD CONTAIN FOLLOWING DETAILS:**

- a. Stamped and signed copy of all pages of tender document and corrigenda (if any) with all supporting documents (as applicable);
- b. Financial documents as mentioned in "Common Requirements" of Annexure-1;
- c. **Signed Copy of un-priced Price bid (Annexure-7) (Price bid without price & with percentage of taxes & duties and details like "quoted/Nil/included" need to be mentioned for each line item.)**
- d. Signed and stamped copy of Technical Specification / Scope of Work as per Annexure 2 with supporting documents if required
- e. Signed and stamped copy of tender terms and conditions as per Annexure 3, 4 & 5;
- f. Checklist duly undersigned with remarks, if any applicable as per Annexure-6;
- g. List of Deviation (if Any) as per Annexure-8;
- h. Vendor Details as per Annexure-9;
- i. NEFT mandate Form as per Annexure-10;
- j. Format of BG towards SD per Annexure-11;
- k. Security Deposit formats per Annexure-12;
- l. Power of Attorney document as per Annexure-13;
- m. Self-Declaration as per Annexure-14;
- n. Details of Legal Case(s) pending Format as per Annexure-15;
- o. Indemnity Bond as per Annexure-16.

**All documents provided along with techno-commercial part should be stamped and undersigned. HCSL reserves the right the reject the bid in case of any discrepancies on the mentioned aspect.**

### **3 PRICE PART:**

The price part should contain the following details:

- The price correspondent to each item;
- Taxes as applicable

**The price bid to be offered in the given format (Annexure – 7). Deviations to the format as given would be liable to decline of the bid so submitted.**

4. **Validity:** The offer should be valid for a minimum period of 2 (Two) months of date of tender opening.
5. HCSL reserves the right to alter, modify the scope of supply, at their discretion.
6. **Un-priced bid** to be submitted along with techno-commercial part (Part – I – Techno-commercial Bid) with details like percentage of taxes & duties applicable & details like "quoted/nil/included" to be mentioned for each line item as per Annexure-7.
7. **Tenders should be submitted through E-mail only. No hard copy of the tender documents will not be accepted** and may subject to rejection of the bid as a whole by the HCSL authority.
8. **Price part should be submitted exactly in the Price Format as provided (Annexure 7).** Price should be quoted separately for each item shown in the format. Combining of figures against more than one item and ambiguous clauses will lead to rejection of the bid.
9. **Unprotected Price Bids/ Price Bids which are not password protected** will be subject to rejection/disqualification of bid and HCSL as a whole reserve the right to cancel out such bids.
10. Check lists, technical & commercial, duly filled & signed should be submitted along with Part-I "Techno-Commercial" bid. Non-receipt of this document may lead to rejection of the offer.
11. The Techno-commercial part alone will be opened initially on the due date of tender. The price part will be opened only after evaluation of the Techno commercial part. Firms will be intimated the date of opening of the price part, whose Techno-commercial bid is acceptable, in due course. *Tenderers shall not be allowed to attend the Techno commercial bid opening.*
12. After submission of quotation / price opening, no unsolicited correspondence will be entertained.
13. Bidders can contact Officer-in-charge of the work which is indicated in the Tender Notice for any clarification before submitting the offer. If clarifications/details are not obtained before the offer is submitted, no claim on this account will be admitted.
14. The bidder shall be deemed to have carefully examined the scope of work, technical specifications, general & special terms and conditions, and other necessities mentioned in the tender and have to satisfied himself as to the nature and character of the works to be carried out, the site conditions and all relevant matters & details.
15. All pages of offers including price bids, supporting documents etc. are to be signed by authorized signatory in each page and company seal should be affixed on each page. In case of non-compliance, offer is liable for rejection.



16. Bidder should make sure that they comply with all the techno-commercial details in addition to adhere to all technical specifications during the whole process (i.e. Starting from bid submission to carry out scope of work as per work agreements and as applicable) and provide necessary MSE/NSIC Certificates to avail exemptions, if applicable.
17. Participants/Vendors are requested to obtain clarifications, if any, and carefully study the documents and the scope of services and HCSL, before submitting your offer.
18. If any case of the above conditions is not acceptable to the tenderer, it should be specifically indicated in the tender, failing which it will be presumed that all the terms and conditions are acceptable.
19. HCSL have full right upon deviations, if any, including rejecting the partial scope/ complied offers.
20. Offers should be clear and unambiguous. Incomplete/ambiguous offers are likely to be rejected.
21. Bid Submission shall include Amendment / corrigendum / response to pre bid query duly signed and accept (if any).
22. After scrutinization of documents (Part – I) provided by the bidders, and after successful techno-commercial qualification, bidders will be contacted prior to opening of price bid. Passwords will be asked before opening of price bid. Authorized representor is required during the opening of price bid.
23. The bidders are advised to familiarize themselves with the site conditions before quoting.
24. Supplier should depute only persons who are entitled for exemption for income tax in India or any site work. In case the supplier does not depute such persons, the tax liability will be to supplier's account.
25. After submission of tender, no unsolicited correspondence will be entertained.
26. Hooghly Cochin Shipyard Limited does not bind itself to accept the lowest or any tender but reserves to itself the right to reject any or all or a part of any tender at its discretion.
27. During the evaluation of tender, officer-in-charge may seek clarifications from the bidders. Clarification if any shall be given in writing/e-mail. Officer-in-charge's decision will be final and binding on the bidder.
28. All applicable taxes, duties, transportation, delivery, etc at HCSL Nazirgunge, should be included in the rate quoted, unless specified otherwise. HCSL reserves the right for the deduction of taxes and duties as applicable from the bill or invoice.
29. Bidders to note that no advance payment will be made by HCSL against purchase order issued.



**For Hooghly Cochin Shipyard Limited**

Techno-Commercial Checklist for Tender for Fabrication, Installation, Testing & Commissioning of Four Piping Systems for MPV at HCSL				
Sl. No.	DESCRIPTION	COMPLIANCE		REMARKS
		YES	NO	
1	Submission of Tender in two (2) parts – Techno-commercial & Price (Password protected)			
2	Work Completion Period as per Tender			
3	EMD			
4	Validity of offer – 60 Days			
5	Payment Terms acceptance			
6	The Prices offered should remain firm till the completion of work, in case the work order is placed with you.			
7	Have you specified Taxes, duties, levies etc., if any, in the offer?			
8	Signed and stamped copy of unpriced bid (mentioning taxes and duties) and “quoted/nil/included” against each line item as per Annexure 7 to be included in the techno- commercial offer. Please confirm			
9	Compliance with Pre-qualification criterion with supporting documents			
10	Self-attested copy of PAN Card, GST, ESI, EPF and MSME/NSIC registration certificate.			
11	Disputes in connection with contract subject to jurisdiction of courts at Kolkata, India.			
12	Defect Liability Period as per relevant clause in the terms of enquiry.			
13	L.D. payable as per relevant Clause in the General terms of enquiry.			
14	Termination of contract/Risk purchase as per relevant clause in the General terms of enquiry.			
15	Contractor to provide minimum wage structure as prescribed by <b>Central Govt.</b>			
16	ITR, Balance Sheets, Profit & loss statement for <b>2021-22, 2022-23, 2023-24</b> submitted with the Bid.			
17	List of Deviations to be submitted as per Annexure 8			
18	Supplier should have minimum average annual turnover of <b>Rs. 6.5 Lakhs</b> as on 31 <sup>st</sup> March (FY <b>2021-22, 2022-23, 2023-24</b> ) Supporting document to be submitted along with technical bid			
19	Confirm all other terms and conditions of enquiry are acceptable.			

**PRICE BID FORMAT****Fabrication, Erection, Dry Survey and Pressure Testing of Various Pipe System for 2200T MPV at HCSL, Howrah**

Description of Works	Qty	U O	Unit Rate	Amount (without GST) (INR)	GST Amount (INR)	Total Amount (Including GST) (INR)
	(A)	M	(B)	(C=A*B)	(D)	(E= C+D)
Fabrication and Erection, Dry Survey and Pressure Testing of <b>SW Cooling System</b> for 2200T MPV at HCSL, Howrah	LS	1				
Fabrication and Erection, Dry Survey and Pressure Testing of <b>Lub Oil System</b> for 2200T MPV at HCSL, Howrah	LS	1				
Fabrication and Erection, Dry Survey and Pressure Testing of <b>Sanitary System</b> for 2200T MPV at HCSL, Howrah	LS	1				
Fabrication and Erection, Dry Survey and Pressure Testing of <b>Oil Water System</b> for 2200T MPV at HCSL, Howrah	LS	1				
Supply of all Material as per enclosures A, B , C & D	LS	1				
<b>Total Amount without GST (INR) (C1+C2+C3+C4+C5)</b>						
<b>Total GST Amount (INR) (D1+D2+D3+D4+D5)</b>						
<b>Total Amount Including GST (INR) (E1+E2+E3+E4+E5)</b>						
<b>Total Amount Including GST (INR) (In Words)</b>						

te:

The quoted price will be valid for a period of 2 (Two) months.

Quoting for all serials is mandatory. Partially quoting for few serials shall result in rejection of the bid.

1 Bidder will be evaluated based on the combined cost of all the items excluding GST.

Rate agreed upon as per quotation shall remain firm and fixed till conclusion of contract.

Bidders shall quote total amount in figures and in words. Corrections and additions if any must be attested / duly signed by the bidder. In the case of error in multiplication / addition in amount calculated, unit rate quoted will be considered as correct and the amount will be calculated accordingly. Conditional rebates & discounts, incomplete/ambiguous offers are likely to be rejected. Bidder has to submit the price bid as mentioned in the format only, otherwise bid will be rejected

7. Un-priced bid to be submitted along with techno-commercial part (**Part – I – Techno-commercial Bid**) with details like **“quoted/nil/included”** to be mentioned for each line item

\*Any modifications or alterations or additional notes added to the above format will straight away leads to rejection of the offer.

Signature:

Address of the contractor:

Seal:



Following information is required for applicable rates and will be used in case if any modifications or growth of work is required.

This won't be used for L1 determination for this tender:

Size	SMLS Carbon Steel ASTM A106 Gr.B /A53 Gr.B (INR without GST) Per Inch Dia. Rates	Size	SMLS Carbon Steel ASTM A106 Gr.B / A53 Gr.B (INR without GST) Per Inch Dia. Rates
15NB SCH 40		15NB SCH 80	
20NB SCH 40		20NB SCH 80	
25NB SCH 40		25NB SCH 80	
32NB SCH 40		32NB SCH 80	
40NB SCH 40		40NB SCH 80	
50NB SCH 40		50NB SCH 80	
65NB SCH 40		65NB SCH 80	
80NB SCH 40		80NB SCH 80	
100NB SCH 40		100NB SCH 80	
125NB SCH 40		125NB SCH 80	
150NB SCH 40		150NB SCH 80	
200NB SCH 40		200NB SCH 80	
250NB SCH 40		250NB SCH 80	
Acid Pickling (Per KG)		Galvanizing Cost (per KG)	

Signature:

Address of the contractor:

Seal:

COMPLIANCE STATEMENT- LIST OF DEVIATIONS		PAGE 1 OF 1
<b>Tender Name:</b> Fabrication, Installation, Testing & Commissioning of Piping Systems for Multipurpose Vessels at HCSL, Nazirgunge unit, Howrah.		
<b>TENDER NO:</b> HCSL/OPS/SB/TEN/2024/052		<b>DATE:</b> 13-12-2024
We hereby confirm and truly declare that our Offer / Bid No. ....dated .....is in full compliance with the documents issued against the Tender No. ....dated -----, except for the deviations listed below:		
<b>LIST OF DEVIATIONS</b>		
Sl. No.	Description / Tender Reference	Reasons for Deviation
Name of tenderer: Date: Signature		
Name & Designation		Seal &
(Company Seal)		

**Vendor details (to be submitted along with TECHNICAL BID)**

1	Name of Bidder/Firm	
2	Registered office Address of Company/firm in Kolkata/Howrah: Local office address at Kolkata/Howrah (if held):	
3	Telephone No./Fax No./Mobile No	
4	E-mail address:	
5	Names of the contact person & Designation: (of person in connection with this tender) :	1) 2) 3)
6	Type of Entity-Pro praetorship/Partnership firm/company/NSIC/MSE Category etc. (Please attach registration certificate of Firm/Partnership agreement/proprietorship documents)	
7	Cost of Tender Details (DD No. Name of Bank)	
8	EMD Details (DD No. Name of Bank)	
9	PAN Card Number (Self-attested copy of PAN card has to be Submitted)	
	GST Registration No. (Self-attested copy has to be Submitted)	
10	Whether the agency has been blacklisted/debarred or given tender holiday or contract terminated before expiry of the contract period by any govt. autonomous bodies/organizations where bidder has provided services earlier due to deficiencies in service or misconduct etc.	Yes/No (Please tick as applicable) If yes, please furnish details on a separate sheet

**Certified that the above information is true to the best of our belief and information.**

**Place:**

**Date:**

**Signature of Supplier/Authorized signature of firm/agency:**

**Name of Supplier or authorized signatory of firm/agency:**

**Designation:**

NEFT mandate form  
(ON THE LETTER HEAD OF THE BIDDER)

**Electronic Payment Mandate Form**

(Mandate for receiving payments through RTGS/NEFT Hooghly Cochin Shipyard Ltd)

- 1) Vendor Name
- 2) Vendor Address with Phone No
- 3) Vendor Code
- 4) Permanent Account No. (PAN)
- 5) Particulars of Bank Account
  - a. Name of the Bank
  
  - b. Name of the Branch
  
  - c. Branch Code
  - d. NEFT Code of the Bank
  - e. City Name
  - f. Branch Location
  - g. Branch Telephone No.
  - h. Bank IFSC Code
  - i. 9-Digit MICR Code

**(Where MICR is starting with "0". Please take the correct code from your bank for proper identification of city, bank, branch)**

i. Type of the Account (S.B  
Current or

Cash Credit) with code  
(010/011/013)

j. Account Number (as  
appearing on the cheque book)



- 6) Email Address of Vendor
- 7) Date of Effect of RTGS/NEFT in your Bank

We hereby declare that the particulars given above are correct and complete. If the transaction is delayed or lost because of incomplete or incorrect information, we would not hold the company responsible.

(.....)  
Signature of Employee

**Bank Certificate**

We certify that \_\_\_\_\_ has an Account No. \_\_\_\_\_ with us and we confirm that the details given above are correct as per our records.

Date:

Place:

(.....)  
Authorized official of Bank

**Note: Please enclose a cancelled un-signed cheque leaf to enable us to verify the details mentioned above.**

**Form of bank Guarantee towards EMD**

(On stamp paper of value Rs. 200/-)

This deed of GURANTEE made on ..... day of ..... Two thousand Eighteen between HCSL on the one part and ..... (Name and address of the bank) of the other part is as follows: -

In consideration of the HCSL having allowed M/s..... (Hereinafter referred to as 'the Supplier') to submit Tender No..... to them without Earnest Money according to the conditions of such Tender Notification.

We..... (here enter the name of 'the Bank') a Company incorporated under the .....Act and having its registered office at .....(hereinafter referred to as 'the bank') undertake to pay to HCSL on demand at Kolkata the sum of money payable as Earnest Money in respect of the Tender No.....made by the Supplier, in case the Supplier withdraws the tender before the date of firmness stipulated or when the tender is accepted by or on behalf of the HCSL the Supplier makes default in furnishing the Security Deposit or in entering into an agreement as required by the HCSL or otherwise commits any breach of the terms and conditions of the tender.

We, .....Bank Guarantee to pay the amount due and payable under this guarantee without any demur merely on demand from the HCSL. Any such demand made on the Bank shall be conclusive as regards the amount due and payable by the Bank under this guarantee. The liability of the surety shall be restricted to Rs .....(Rs..... only)

This guarantee shall not be avoided, released or affected by any variation in the terms of the tender, acceptance or the contract between the Contractor and the HCSL or any neglect indulgence or forbearance by the HCSL.

This guarantee shall remain in full force and effect during the period that would be taken for the finalization of the tender and till the HCSL certifies that the terms and conditions of the said tender have been fully and properly carried out by the Supplier and accordingly discharges this guarantee or for Six Months from the date of issue of this guarantee whichever is earlier. A notice of the claim under this guarantee may be served on the Bank within Six Months after the said period in which

case the same shall be enforceable against the Bank notwithstanding the fact that the same is enforced after the expiry of the said period.

The decision of the CEO, HCSL as to whether the occasion or the ground has arisen for the demand of the surety form Bank shall be final. The HCSL shall be at liberty to act as though the Bank were the principal debtor.

We, the said Bank lastly undertake not to revoke this guarantee during its currency except with the previous consent of the HCSL in writing and agree that any change in the constitution of the said contractor or the said Bank shall not discharge our liability hereunder.

In witness whereof we have hereunto set our hand and seal this ..... day  
.....of..... Two thousand and

Place:

Date:

**Bank guarantee in lieu of security deposit/  
Warranty guarantee**

To  
HOOGHLY COCHIN SHIPYARD LTD  
(Govt. of India Enterprise)  
Satyen Bose Road,  
Danesh SK Lane (PO),  
Nazirgunge, Howrah,  
West Bengal - 711109.

WHEREAS ..... (Name & Address of Supplier) (hereinafter called "the Supplier")  
has ..... undertaken, ..... in ..... pursuant ..... of  
Contract..... No..... Dated:..... to execute ..... (Name  
of Contract and brief description of works) (hereinafter called "the Contract").

AND WHEREAS it has been stipulated by HOOGHLY COCHIN SHIPYARD LTD (The Buyer –  
hereinafter called "HCSL") in the said contract that the Supplier shall furnish HCSL with a Bank  
Guarantee for the sum specified therein as security for compliance with the Supplier's  
obligations in accordance with the Contract.

AND WHEREAS we have agreed to give the Supplier such a Bank Guarantee.

NOWTHEREFORE we.....(Name of the Bank) having its Head Office  
at.....(Address of Head Office) and acting through its branch office  
at.....(Address of the executing branch)(hereinafter called "the Bank") hereby  
affirm that we are the Guarantor and responsible to HCSL, on behalf of the Supplier upto a total  
of.....(amount of Guarantee) in words).

We, the bank, hereby irrevocably undertake to pay you any amount not exceeding in total the  
Guarantee Amount upon receipt by us of your demand in writing accompanied by the following  
documents:

1. Your signed statement certifying that the Supplier is in breach of his obligation(s) under  
the Contract and the respect in which the Supplier is in breach.
2. Your signed statement certifying that the Supplier has been given a prior written notice by  
email from you to make good the aforesaid breach and that the Supplier still failed to fulfill  
the Contract within 30 days of such notice. A copy of such notice given by email to the  
Supplier shall be attached to the demand for payment.

Any demand for payment should contain your authorized signatures which must be authorized by  
your bankers or by a notary public.

We, the Bank, further agree that no change or addition to or other modification of the terms of  
the Contract or of the Works to be performed there under or of any of the Contract documents  
which may be made between HCSL and the Supplier shall in any way release us from any  
liability under this guarantee, and we hereby waive notice of any such change, addition or  
modification. We, the Bank, further agree that any change in the constitution of the said  
contractor or the said bank shall not discharge our liability hereunder.

**Notwithstanding** anything contained herein:

1. Our liability under this Bank Guarantee shall not exceed .....(only).



2. This Bank Guarantee shall be valid upto (date) and

3. We are liable to pay the guaranteed amount or any part thereof under this bank guarantee only and only if HCSL serve upon us a written claim or demand on or before.....(validity date).

Any demand for payment under this guarantee must be received by us at this office during working hours on or before the validity date. Should we receive no claim from you by the validity date, our liability to you will cease and the guarantee will definitely become null and void whether returned to us or not.

Yours truly,

Signature and seal of the guarantor:.....

Name of Bank:.....

Address:.....Date:.....

<sup>[1]</sup>An amount shall be inserted by the Guarantor, representing the percentage of the Contract Price specified in the Contract and denominated in respective Dollars / Indian Rupees/Other Currency.

**POWER OF ATTORNEY**

*(On Applicant's Letter head)*

(Date and Reference)

To  
The Assistant General Manager  
Hooghly Cochin Shipyard Limited  
Nazirgunge, Howrah-711109, West  
Bengal.

**Subject: Power of Attorney**

Mr. / Mrs. / Ms..... (Name of the Person(s),  
domiciled at ..... (Address),  
acting as..... (Designation and name of the company), and  
whose signature is attested below, is hereby appointed as the Authorized Representative and  
authorized on behalf of .....  
(Name of the company) to provide information and respond to **enquiries etc.** as may be required by  
the Employer for the project of .....  
(Project title) and is hereby further authorized to sign and file relevant documents in respect of the  
above.

(Attested signature of Mr. \_\_\_\_\_).

For.....

(Name & designation)

(Company Seal)

**Self-Declaration to be given by the bidder in Letter head**

Bid's Reference No. & Date:

Bidder's Name & Address:

Person to be contacted:

Designation:

Telephone No.:

Fax No.:

Email:

1. We do hereby declare that we have not been debarred/black listed by HCSL or by any of the Public Sector Undertaking or Government department etc.

2. If HCSL finds that, we have been blacklisted/ debarred by any of the Public Sector Undertaking or Government department, and then HCSL can reject the offer or terminate the contract at any point of time. In such case, we are aware that, EMD, security deposit, performance guarantee etc will be forfeited by HCSL. Further we are confirming herewith that, any loss that has happened to HCSL due to this will be compensated by us.

For and on behalf of the firm  
(Firms Name & Address)

(Signature of Authorized Signatory)

Name:

Designation

Phone No.:

Seal:

Date: .....

Place: .....

**Form of Legal Case (Sample Format)**

Details of legal cases pending against the firm for the last five years

<b>SL. NO.</b>	<b>ORGANISATION AGAINST WHOM THE LITIGATION IS INVOLVED</b>	<b>BRIEF DETAILS OF DISPUTE</b>	<b>AMOUNTS INVOLVED (Rs. ....)</b>	<b>PRESENT STATUS</b>	<b>Remarks</b>

- If no Cases pending please mention as "NIL" and submit the above form.

**SIGNATURE OF BIDDER**



**INDEMNITY BOND**

To  
Hooghly Cochin Shipyard Ltd  
(Govt. Of India Enterprise)  
Sateyn Bose Road, Danesh Shaikh Lane  
Nazirgunge, Howrah  
West Bengal-711109

Gentlemen:

In accordance with the Conditions of Contract No. ....  
Date..... (Hereinafter called the Contract) for the supply/ work of...  
..... (Name of the item), M /s .....  
..... (Name and address of  
Contractor ) ( herein after called the Contractor) shall deposit with HOOGLY COCHIN  
SHIPYARD LTD, HOWRAH, ( herein after called ' HCSL') An Indemnity Bond to indemnify HCSL  
under the Contract for an amount of Rs ..... (amount of Bond... ( in  
words ) , in consideration of HCS L effecting advance payment/ free issue of materials a  
mounting to Rs .....(in figures ; ( Rupees.....( 1 ) words , being 1 5 % (   
fifteen percent ) of contract value.

NOW THEREFORE we ...  
..... (Name of the contractor) having registered office at ...  
..... (Add res s of the Registered Office) and acting  
through its branch office at ... (Address of the executing branch if any),  
agree unconditionally y and irrevocably to indemnify HCS L on its first demand without  
whatsoever right of objection on our part in the amount not exceeding Rs .....  
..... (Amount of Bond)  
Rupees..... only (in words)

We, the Contractor, further agree that no change or addition to or other modification of the terms  
of the Contract or of Works to be performed there under or of any of the Contract documents  
which may be made between HOOGLY COCHIN S HIPYARD LTD, HOWRAH and us shall in

~~any way release us from any liability under this Indemnity Bond, and we hereby waive notice of any such change, addition or modification.~~

The guarantee shall remain valid and in full effect from the date of the advance payment under the Contract until HOOGLY COCHIN SHIPYARD LTD, HOWRAH receives full quantity from the Contractor under the said Contract

Notwithstanding anything contained herein:

1. Our liability under this Indemnity Bond shall not exceed Rs.....(Rupees..... only)
2. This Indemnity Bond shall be valid up to ( date) and
3. We are liable to pay the amount of this Bond or any part thereof under this Bond only and only under the above items if you serve upon us a written claim or demand on or before.....(date).

Signature & Company's Common seal

Name of Contractor

Address -----  
-----

Date-----

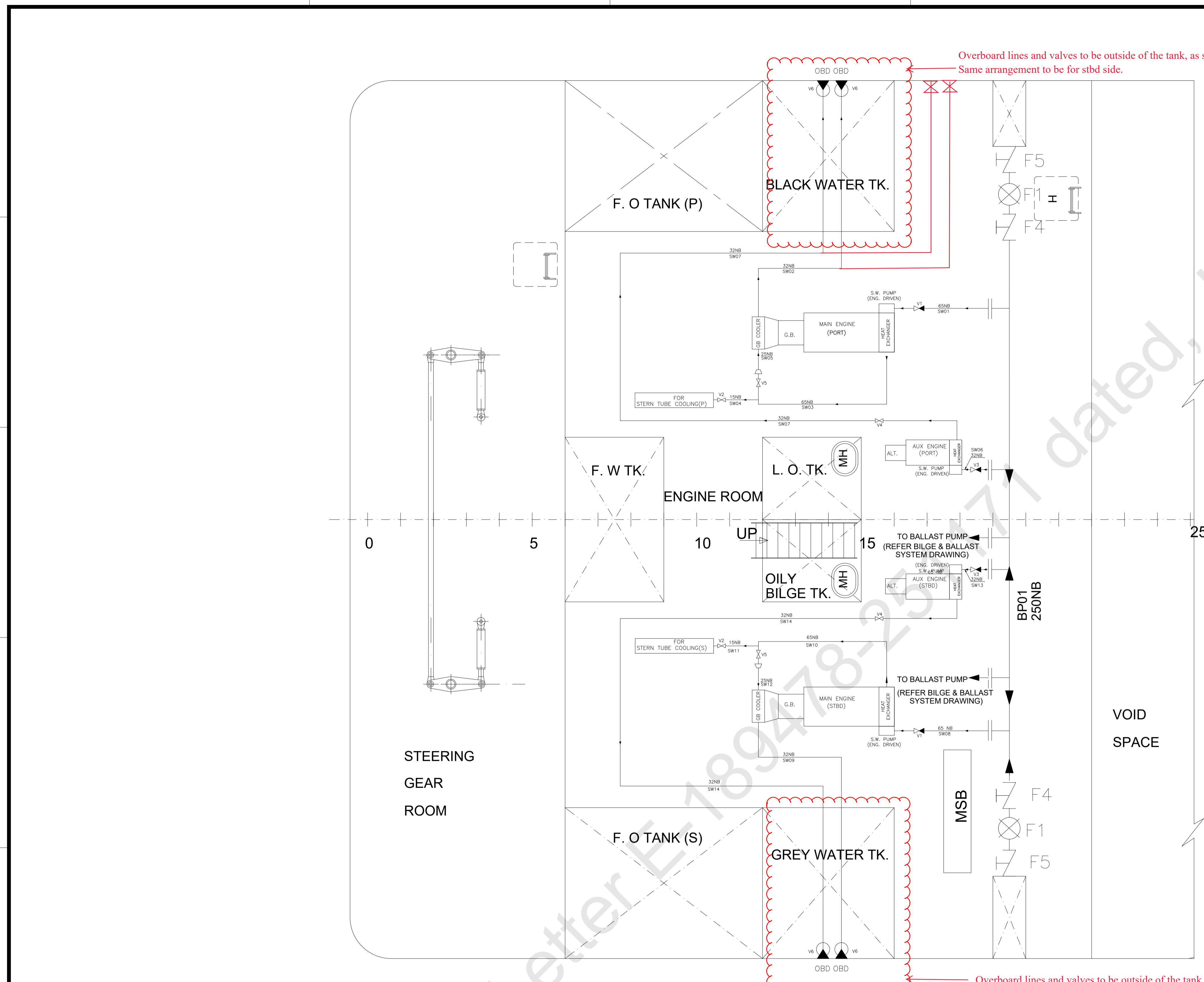

Overboard lines and valves to be outside of the tank, as shown  
Same arrangement to be for stbd side.

Overboard lines and valves to be outside of the tank.

VALVE SPECIFICATION

VL NO.	DESCRIPTION	SIZE	MATERIAL	QTY	REMARKS
V1	SDNR VALVE	65 NB	CI/G.M	2 NOS.	--
V2	SDSL VALVE	15 NB	G.M	2 NOS.	CLASS APPROVED
V3	SDNR VALVE	32 NB	CI/G.M	2 NOS.	--
V4	SDSL VALVE	32 NB	CI/G.M	2 NOS.	--
V5	SDSL VALVE	65 NB	CI/G.M	2 NOS.	--
V6	SDNR RT.ANGLE VALVE (OBD)	32 NB	G.M	4 NOS.	CLASS APPROVED

PIPE SPECIFICATION

SIZE	THICKNESS (mm)	MATERIAL	REMARKS
65 NB	3.65	M.S. GALV.	
32 NB	3.25	M.S. GALV.	
25 NB	2.65	M.S. GALV.	

THE REMAINING REQUIREMENTS OF THE RULES FOR PUMPING AND PIPING TO BE COMPLIED WITH SO FAR AS THEY ARE APPLICABLE

FLEXIBLE HOSES TO BE OF APPROVED TYPE AND ONE SPARE OF EACH TYPE TO BE CARRIED ON BOARD READY FOR MOUNTING

MATERIALS TO BE MANUFACTURED AND TESTED IN ACCORDANCE WITH THE RULES OF THE SOCIETY

SEE LETTER E-189478-251171



AS AMENDED

SYM	DESCRIPTION
	SDSL VALVE
	SDNR VALVE
	SDNR RT.ANGLE VALVE (OBD)

NOTE:

1. ALL PIPES WILL BE SUITABLY CLAMPED & FITTINGS TO PREVENT VIBRATION.
2. EXACT SIZE OF THE COOLING PIPE TO BE AS PER ENGINE, DG & GB MANUFACTURER'S RECOMMENDATION.
3. OBD WILL BE AT 300MM ABOVE FROM LWL.

REV	MODIFICATION	BY	CHK'D	DATE	
PROJECT	2200 TONNE / 128 TEU MULTIPURPOSE VESSEL				
TITLE	SW COOLING SYSTEM				
DRAWN BY :	KDG	DRG NO :	22004/410	SCALE :	1 : 100
CHECKED BY :	JR	SHEET :	01	SIZE :	A1
		DATE :	15/05/2023	REV. :	0
THIS DOCUMENT AND THE INFORMATION IT CONTAINS IS COPYRIGHT AND REMAINS THE PROPERTY OF MARITCONS PRIVATE LIMITED. IT IS NOT TO BE COPIED IN WHOLE OR IN PART OR DISCLOSED TO ANY THIRD PARTY FOR ANY PURPOSE WHATSOEVER WITHOUT PRIOR WRITTEN CONSENT.					
CLIENT	JAK MARITIME & LOGISTICS PRIVATE LIMITED.			HULL NO.	004/22004
BUILDER	HOUGHLY COCHIN SHIPYARD LIMITED				
DESIGNER	Maritcons Private Limited				
	TEL : (+91)9007227123 webmail.maritcons.com				



STP CONNECTION DETAILS			
Description	Size	Type	
TP01	SEWAGE INLET 1	DN150,PN10	FLANGE, EN 1092
TP02	SEWAGE INLT 2	DN65,PN10	FLANGE, EN 1092
TP03	EFFLUENT DISCHARGE	DN25,PN10	FLANGE, EN 1092
TP04	SLUDGE DISCHARGE	DN25,PN10	FLANGE, EN 1092
TP05	TECHNICAL WATER INLET	DN25,PN10	FLANGE, EN 1092
TP06	VENTILATION	DN65,PN10	FLANGE, EN 1092
TP07	OVERFLOW	DN50,PN10	FLANGE, EN 1092
TP08	COMPRESSED AIR INLET (OPTIONAL)	DN25,PN10	FLANGE, EN 1092

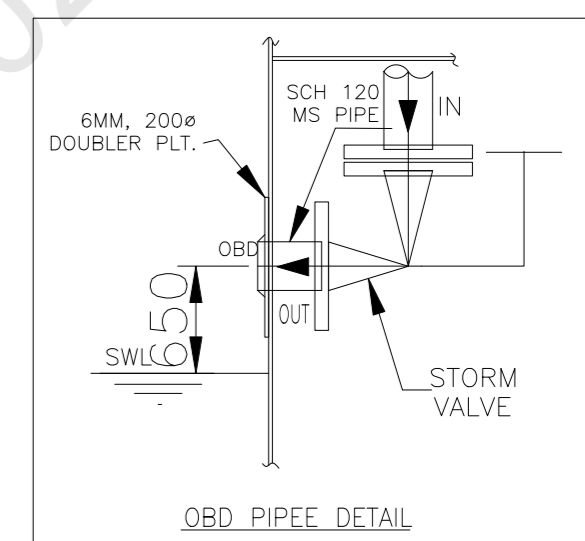
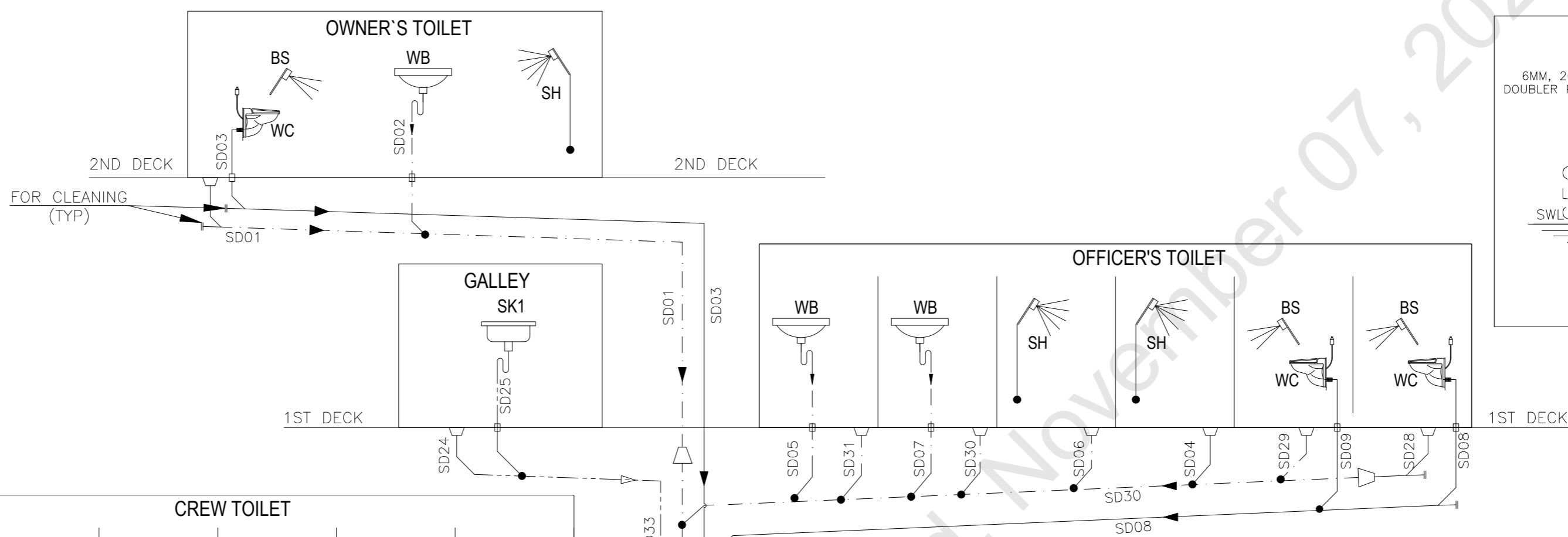

MARPOL STANDARD CONNECTION

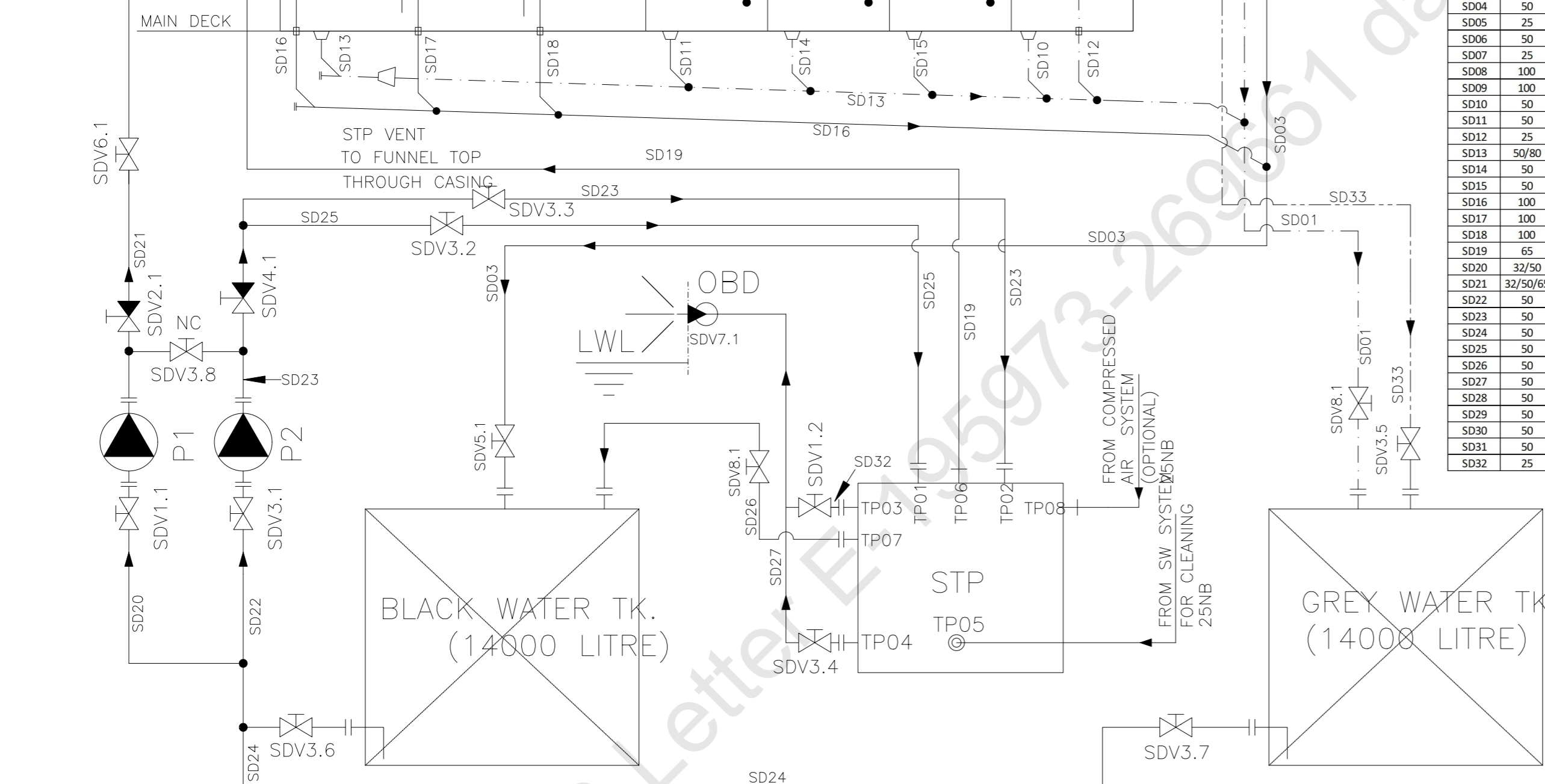

PIPE NO.	N.B.	THICKNESS	MATERIAL	REMARKS
SD01	50/80	4.47/4.85	GI, ERW PIPE, HEAVY (C-CLASS)	
SD02	25	4.05	GI, ERW PIPE, HEAVY (C-CLASS)	
SD03	100	5.4	GI, ERW PIPE, HEAVY (C-CLASS)	
SD04	50	4.47	GI, ERW PIPE, HEAVY (C-CLASS)	
SD05	25	4.05	GI, ERW PIPE, HEAVY (C-CLASS)	
SD06	50	4.47	GI, ERW PIPE, HEAVY (C-CLASS)	
SD07	25	4.05	GI, ERW PIPE, HEAVY (C-CLASS)	
SD08	100	5.4	GI, ERW PIPE, HEAVY (C-CLASS)	
SD09	100	5.4	GI, ERW PIPE, HEAVY (C-CLASS)	
SD10	50	4.47	GI, ERW PIPE, HEAVY (C-CLASS)	
SD11	50	4.47	GI, ERW PIPE, HEAVY (C-CLASS)	
SD12	25	4.05	GI, ERW PIPE, HEAVY (C-CLASS)	
SD13	50/80	4.47/4.85	GI, ERW PIPE, HEAVY (C-CLASS)	
SD14	50	4.47	GI, ERW PIPE, HEAVY (C-CLASS)	
SD15	50	4.47	GI, ERW PIPE, HEAVY (C-CLASS)	
SD16	100	5.4	GI, ERW PIPE, HEAVY (C-CLASS)	
SD17	100	5.4	GI, ERW PIPE, HEAVY (C-CLASS)	
SD18	100	5.4	GI, ERW PIPE, HEAVY (C-CLASS)	
SD19	65	4.47	GI, ERW PIPE, HEAVY (C-CLASS)	
SD20	32/50	4.05/4.47	GI, ERW PIPE, HEAVY (C-CLASS)	
SD21	32/50/65	4.05/4.47/4.47	GI, ERW PIPE, HEAVY (C-CLASS)	
SD22	50	4.47	GI, ERW PIPE, HEAVY (C-CLASS)	
SD23	50	4.47	GI, ERW PIPE, HEAVY (C-CLASS)	
SD24	50	4.47	GI, ERW PIPE, HEAVY (C-CLASS)	
SD25	50	4.47	GI, ERW PIPE, HEAVY (C-CLASS)	
SD26	50	4.47	GI, ERW PIPE, HEAVY (C-CLASS)	
SD27	50	4.47	GI, ERW PIPE, HEAVY (C-CLASS)	
SD28	50	4.47	GI, ERW PIPE, HEAVY (C-CLASS)	
SD29	50	4.47	GI, ERW PIPE, HEAVY (C-CLASS)	
SD30	50	4.47	GI, ERW PIPE, HEAVY (C-CLASS)	
SD31	50	4.47	GI, ERW PIPE, HEAVY (C-CLASS)	
SD32	25	4.05	GI, ERW PIPE, HEAVY (C-CLASS)	

FITT. NO.	N.B.	DESCRIPTION	MATERIAL	QTY	REMARKS
SD01 TO SD09	50	DECK SCUPPER	M.S. GALV.	9	
SDV1.1, 1.2	32	SDSL VALVE	CI/GM	2	
SDV2.1	32	SDNR VALVE	CI/GM	1	
SDV3.1, 3.2, 3.3, 3.4, 3.5, 3.6, 3.7 & 3.8	50	SDSL VALVE	CI/GM	7	
SDV4.1	50	SDNR VALVE	CI/GM	1	
SDV5.1	100	SDSL VALVE	CI/GM	1	
SDV6.1	65	SDSL VALVE	CI/GM	1	
SDV7.1	50	STROM VALVE	GM	1	
	100	STROM VALVE	GM	1	

SEE LETTER E-195973-269661



MATERIALS TO BE MANUFACTURED AND TESTED IN ACCORDANCE WITH THE RULES OF THE SOCIETY

SYM	DESCRIPTION	SYM	DESCRIPTION
⊗	DECK SCUPPER	⊗	STROM V/V
OBD	OVERBOARD DISCHARGE	⊗	SDNR VALVE
⊗	SDSL VALVE		

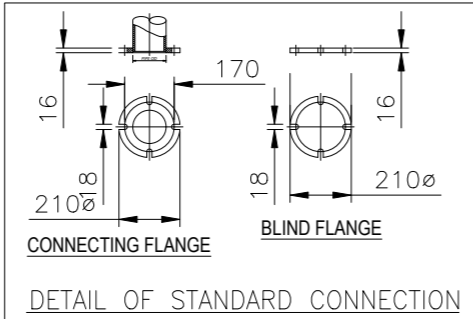

DESCRIPTION	DIMENSION
OUTSIDE DIAMETER	210MM
INSIDE DIAMETER	170MM
FLANGE THICKNESS	16MM
FLANGE TO FACE	18MM
FLANGE TO CENTER	210MM

PUMP SPECIFICATION	
P1	WASTE DISCHARGE PUMP CAPACITY: 2M <sup>3</sup> /HR AT 15 MWC
P2	SANITARY DISCHARGE PUMP CAPACITY: 2M <sup>3</sup> /HR AT 15 MWC

- NOTES :-
- ALL PIPES ARE GI, ERW PIPE, HEAVY (C-CLASS)
  - ALL FLANGES ARE DIN TYPE
  - SYSTEM TO BE TESTED AT NORMAL WORKING PRESSURE AFTER INSTALLATION.
  - INCLINATION OF SOIL PIPES TOWARDS DISCHARGE POINT TO BE MAINTAIN.
  - PUMP SHALL BE FITTED WITH SUCTION AND DISCHARGE PRESSURE GAUGES WITH A ROOT COCK SCUPPERS AND DISCHARGE PIPES SHOULD NOT NORMALLY PASS THROUGH FUEL OIL OR CARGO OIL TANKS WHERE SCUPPERS AND UNAVOIDABLY, THROUGH FUEL OIL OR CARGO OIL TANKS, AND ARE LED THROUGH THE SHELL WITHIN THE TANKS, THE THICKNESS OF THE PIPING SHOULD BE HEAVY(SCH120).
  - OBD PIPE PIECE SHOULD BE GALVANISED.
  - OBD VALVES ARE NORMALLY CLOSED.
  - BLACK WATER TAK & GREY WATER TK CAPACITY 14000 LITRE (APPROX)

REV	MODIFICATION	BY	CHK'D	DATE
B	IBS COMMENTS INCORPORATED. VIDE E-MAIL DATED-29.09.2023	KDG	PM	02/10/2023
A	GENERALLY REVISED & COMMENTS INCORPORATED	AS	JR	26/07/2023

PROJECT: 2200 TONNE / 128 TEU MULTIPURPOSE VESSEL

TITLE: SANITARY DISCHARGE SYSTEM

DRAWN BY: KDG | DRG NO: P008/409 | SCALE: NTS  
 CHECKED BY: JR | SHEET: 01 | SIZE: A2  
 DATE: 28/02/2023 | REV.: B

THIS DOCUMENT AND THE INFORMATION IT CONTAINS IS COPYRIGHT AND REMAINS THE PROPERTY OF MARITCONS PRIVATE LIMITED. IT IS NOT TO BE COPIED IN WHOLE OR IN PART OR DISCLOSED TO ANY THIRD PARTY FOR ANY PURPOSE WHATSOEVER WITHOUT PRIOR WRITTEN CONSENT.

CLIENT: JAK MARITIME & LOGISTICS PRIVATE LIMITED. | HULL NO. 004/22004  
 BUILDER: HOOGHLY COCHIN SHIPYARD LIMITED  
 DESIGNER: Maritcons Private Limited  
 TEL: (+91)9007227123 | webmail.maritcons.com

1

2

3

4

5

6

A

B

C

D

E

F

A

B

C

D

E

F

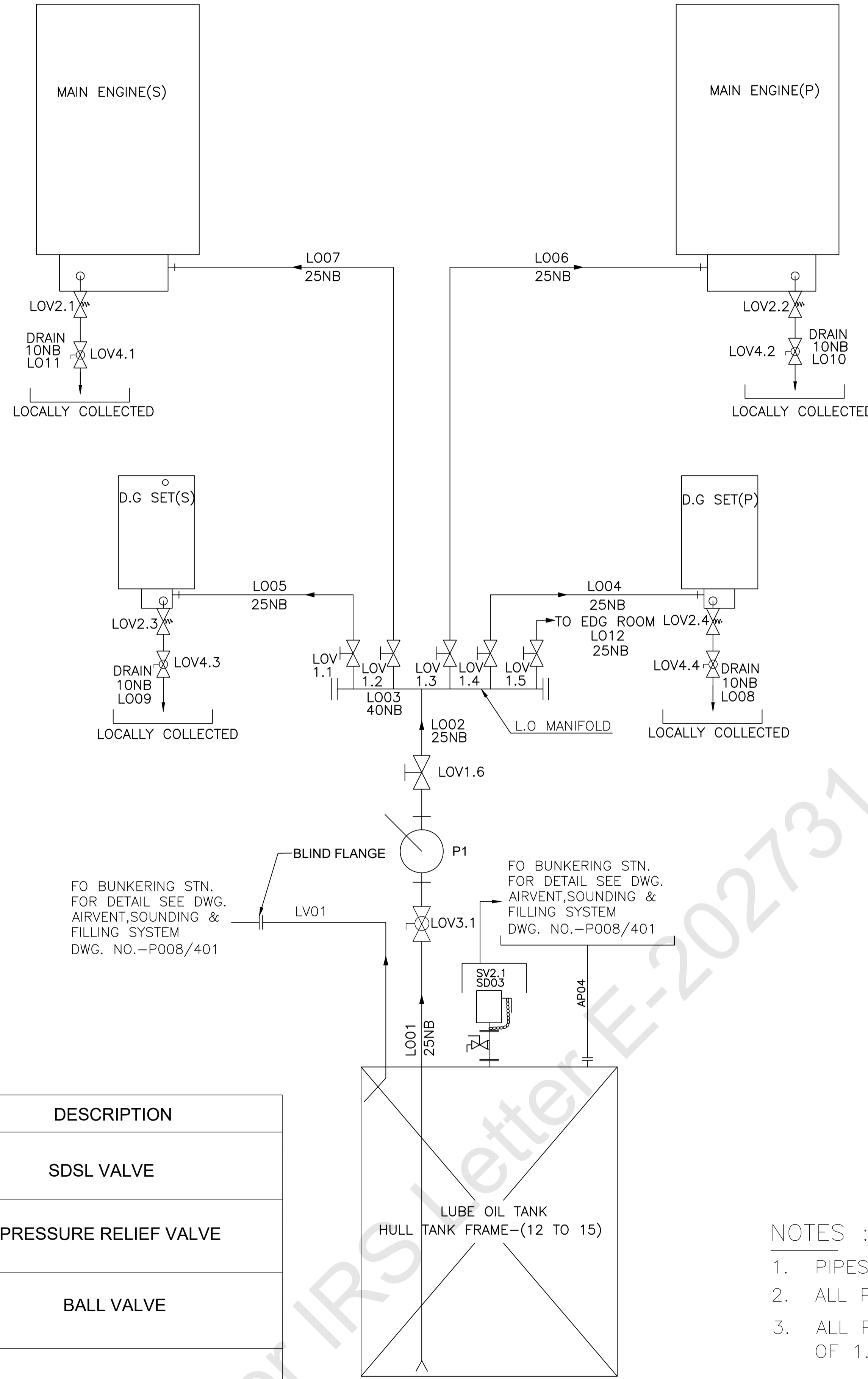

FITT. NO.	N.B.	DESCRIPTION	MATL.	QTY.	REMARKS
LOV1.1 TO 1.6	25	SDSL VALVE	CI/GM	6	
LOV2.1 TO 2.5	10	PRESSURE RELIEF VALVE	CI/GM	5	
LOV3.1	25	BALL VALVE	CI/GM	1	
LOV4.1 TO 4.5	10	BALL VALVE	CI/GM	5	

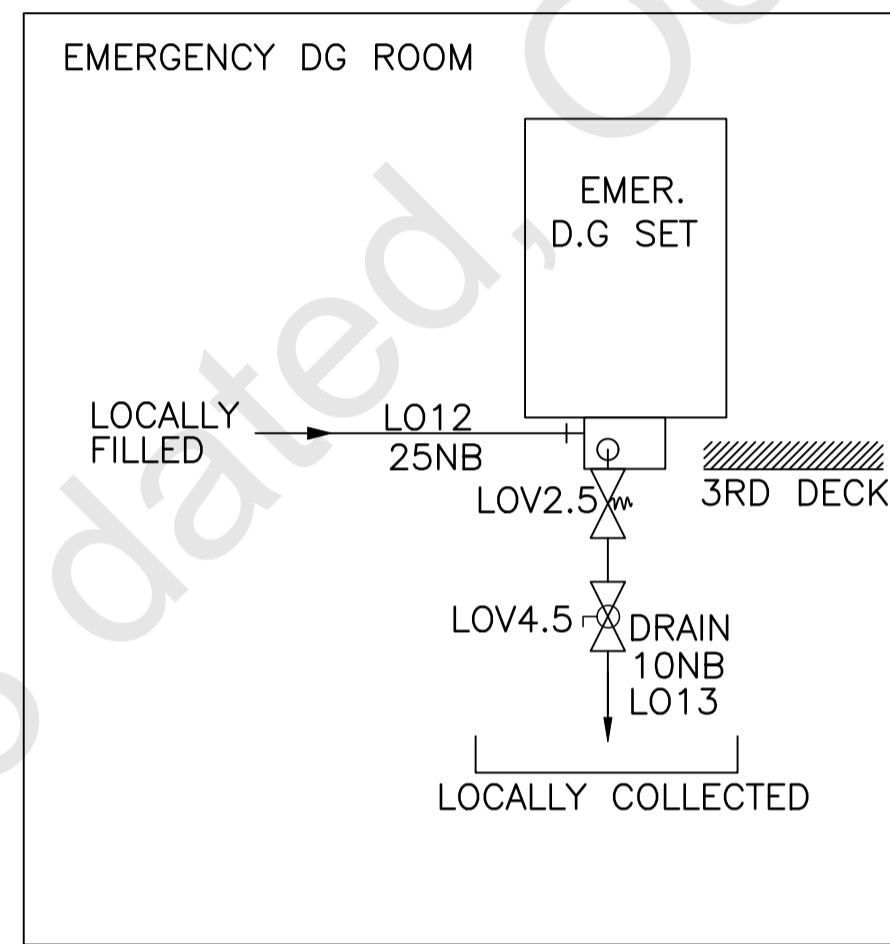

**EQUIPMENT LIST**

ITEM	SYMBOL	DESCRIPTION	CAPACITY	QTY.
P1		SEMI ROTARY HAND PUMP	-	1

SEE LETTER E-202731-268493  
**APPROVED**  
 DATE: 10 Oct 2023  
 INDIAN REGISTER OF SHIPPING  
 MUMBAI

MATERIALS TO BE MANUFACTURED AND TESTED IN ACCORDANCE WITH THE RULES OF THE SOCIETY

**NOTES :-**

- PIPES MATERIAL ARE ASTM 106 GRADE B.
- ALL PIPES ARE SEAMLESS BLACK MS SCH. 40.
- ALL PIPES & FITTINGS ARE TESTED AT A PRESSURE OF 1.5 TIMES THAN THE WORKING PRESSURE.
- THE PIPES ARE ACID PICKLED

SYM	DESCRIPTION
	SDSL VALVE
	PRESSURE RELIEF VALVE
	BALL VALVE
	SDSL VALVE

REV	MODIFICATION	BY	CHK'D	DATE
PROJECT 2200 TONNE / 128 TEU MULTIPURPOSE VESSEL				
TITLE LUBE OIL SYSTEM				
DRAWN BY : KDG		DRG NO : P008/414		SCALE : 1:75
CHECKED BY : JR		SHEET : 01		SIZE : A1
DATE : 21/09/2023			REV. : NIL	
THIS DOCUMENT AND THE INFORMATION IT CONTAINS IS COPYRIGHT AND REMAINS THE PROPERTY OF MARITCONS PRIVATE LIMITED. IT IS NOT TO BE COPIED IN WHOLE OR IN PART OR DISCLOSED TO ANY THIRD PARTY FOR ANY PURPOSE WHATSOEVER WITHOUT PRIOR WRITTEN CONSENT.				
CLIENT JAK MARITIME & LOGISTICS PRIVATE LIMITED.				HULL NO. 004/22004
BUILDER HOOGHLY COCHIN SHIPYARD LIMITED				
DESIGNER Maritcons Private Limited				
TEL : (+91)9007227123 webmail.maritcons.com				

1

2

3

4

5

6



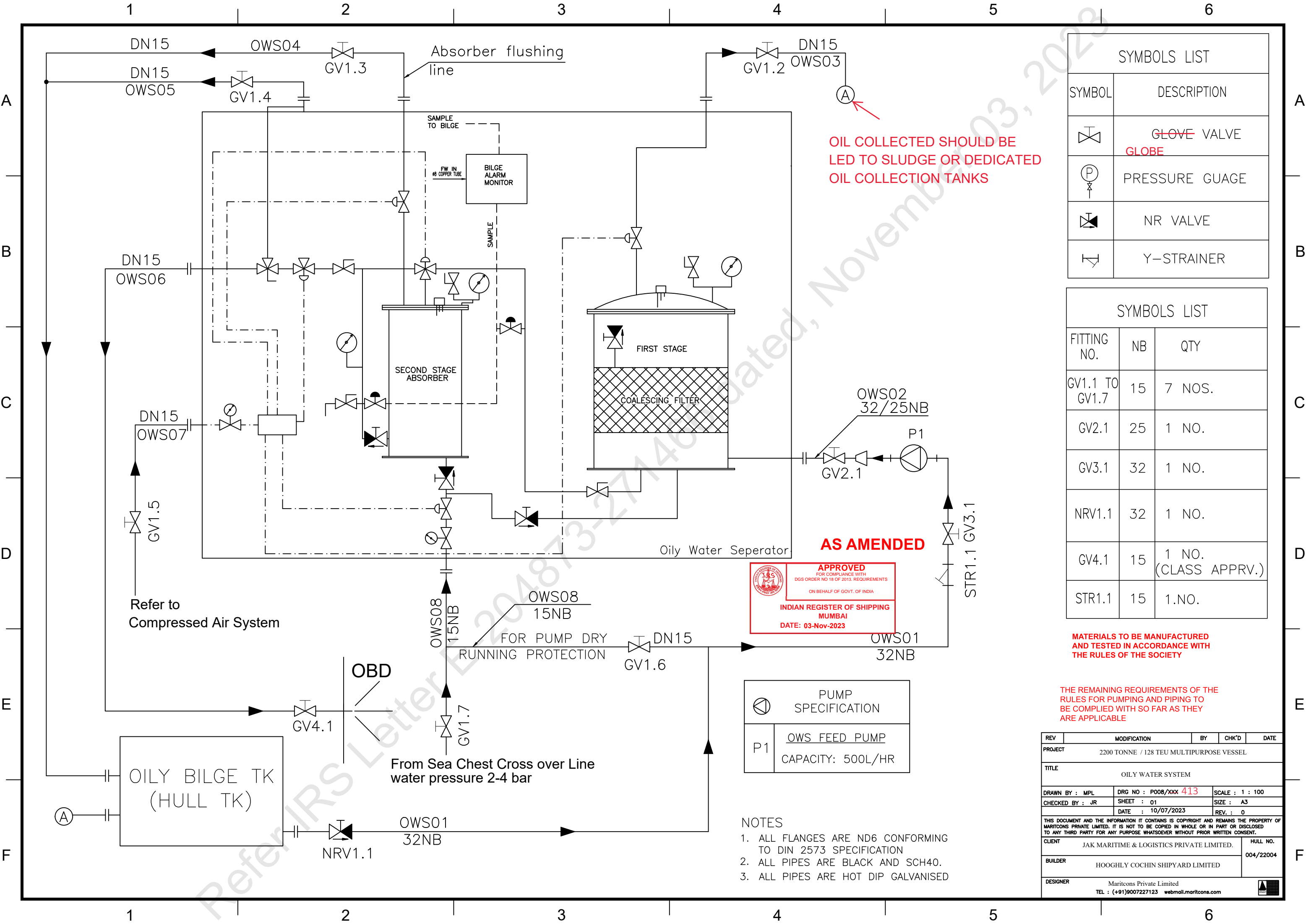

SYMBOLS LIST	
SYMBOL	DESCRIPTION
	GLOBE VALVE
	PRESSURE GAUGE
	NR VALVE
	Y-STRAINER

SYMBOLS LIST		
FITTING NO.	NB	QTY
GV1.1 TO GV1.7	15	7 NOS.
GV2.1	25	1 NO.
GV3.1	32	1 NO.
NRV1.1	32	1 NO.
GV4.1	15	1 NO. (CLASS APPRV.)
STR1.1	15	1.NO.

**APPROVED**  
FOR COMPLIANCE WITH  
DGS ORDER NO 18 OF 2013, REQUIREMENTS  
ON BEHALF OF GOVT. OF INDIA  
**INDIAN REGISTER OF SHIPPING**  
MUMBAI  
DATE: 03-Nov-2023

**PUMP SPECIFICATION**  
P1 OWS FEED PUMP  
CAPACITY: 500L/HR

- NOTES**
1. ALL FLANGES ARE ND6 CONFORMING TO DIN 2573 SPECIFICATION
  2. ALL PIPES ARE BLACK AND SCH40.
  3. ALL PIPES ARE HOT DIP GALVANISED

**OIL COLLECTED SHOULD BE LED TO SLUDGE OR DEDICATED OIL COLLECTION TANKS**

**AS AMENDED**

**MATERIALS TO BE MANUFACTURED AND TESTED IN ACCORDANCE WITH THE RULES OF THE SOCIETY**

**THE REMAINING REQUIREMENTS OF THE RULES FOR PUMPING AND PIPING TO BE COMPLIED WITH SO FAR AS THEY ARE APPLICABLE**

REV	MODIFICATION	BY	CHK'D	DATE
PROJECT: 2200 TONNE / 128 TEU MULTIPURPOSE VESSEL				
TITLE: OILY WATER SYSTEM				
DRAWN BY : MPL	DRG NO : P008/XXX 413	SCALE : 1 : 100		
CHECKED BY : JR	SHEET : 01	SIZE : A3		
	DATE : 10/07/2023	REV. : 0		
THIS DOCUMENT AND THE INFORMATION IT CONTAINS IS COPYRIGHT AND REMAINS THE PROPERTY OF MARITCONS PRIVATE LIMITED. IT IS NOT TO BE COPIED IN WHOLE OR IN PART OR DISCLOSED TO ANY THIRD PARTY FOR ANY PURPOSE WHATSOEVER WITHOUT PRIOR WRITTEN CONSENT.				
CLIENT	JAK MARITIME & LOGISTICS PRIVATE LIMITED.	HULL NO.		004/22004
BUILDER	HOOGHLY COCHIN SHIPYARD LIMITED			
DESIGNER	Maritcons Private Limited TEL : (+91)9007227123 webmail.maritcons.com			