

कोचीन शिपयार्ड लिमिटेड/COCHIN SHIPYARD LIMITED
कोची/COCHIN - 682 015

पोत निर्माण प्रभाग/SHIP BUILDING DIVISION
आउटसोर्सिंग विभाग
OUTSOURCING DEPARTMENT



निविदा दस्तावेज़/TENDER DOCUMENT

TENDER NO. SB-OSD/MPV/883/2024 Dtd 15-07-2024

**ONBOARD INSTALLATION AND FITMENT OF CARGO HOLD
FITTINGS AND LASHING ITEMS IN MULTI PURPOSE
VESSELS 7K MPV – 8 NO VESSELS [SH 029 – SH 036]**

July - 2024



विषय – सूची / CONTENTS

क्र.सं. Sl.No.	विवरण DESCRIPTION	संदर्भ REFERENCE
1	निविदा सूचना TENDER NOTICE	
2	जांच के नियम और शर्तें TERMS & CONDITIONS OF ENQUIRY	अनुलग्नक ANNEXURE I
3	सामान्य शर्तें GENERAL CONDITIONS	अनुलग्नक ANNEXURE II
4	कार्यों का विषय क्षेत्र/ तकनीकी विनिर्देश SCOPE OF WORKS / TECHNICAL SPECIFICATION	अनुलग्नक ANNEXURE III
5	वाणिज्यिक जांच सूची COMMERCIAL CHECK LIST	अनुलग्नक ANNEXURE IV
6	मूल्य बोली प्रारूप PRICE BID FORMAT	अनुलग्नक ANNEXURE V
7	अखंडता समझौता INTEGRITY PACT	अनुलग्नक ANNEXURE VI
8	बयान DECLARATION	अनुलग्नक ANNEXURE VII
9	अनुपालन के लिए मैट्रिक्स COMPLIANCE MATRIX	अनुबंध APPENDIX A
10	वित्तीय क्षमता के लिए प्रारूप FORMAT FOR FINANCIAL CAPABILITY	अनुबंध APPENDIX B
11	प्रासंगिक चित्र RELEVANT DRAWINGS	अनुबंध APPENDIX C

**TENDER ENQUIRY NOTICE – On-board Installation and Fitment of Cargo Hold Fittings and Lashing Items in in Multi-Purpose Vessels- MPV****निविदा सूचना / TENDER NOTICE****कोचीन शिपयार्ड लिमिटेड / COCHIN SHIPYARD LIMITED****पोत निर्माण प्रभाग / SHIP BUILDING DIVISION****आउटसोर्सिंग विभाग****OUTSOURCING DEPARTMENT**

SB-OSD/MPV/883/2024

15 July - 2024

निविदा सूचना / TENDER NOTICE**संक्षिप्त विवरण / BRIEF DETAILS**

निविदा जांच संख्या और तारीख Tender enquiry No. and date	SB-OSD/MPV/883/2024 Dtd: 15.07.2024
कार्य का नाम Name of work	Onboard Installation and Fitment of Cargo Hold Fittings and Lashing Items in Multi-Purpose Vessels 7k MPV – 8 No Vessels [SH 029 – SH 036]
निविदाएं प्राप्त करने की अंतिम तिथि और समय Last date & time of receipt of Tenders (भाग/Part I – तकनीकी-वाणिज्यिक बोली और भाग – II मूल्य बोली/ Techno-Commercial Bid & Part II-Price Bid)	29 July - 2024 at 15.00 Hrs IST
पूर्व बोली बैठक की तारीख Date of Pre bid meeting	22 July - 2024 at 11.00 Hrs IST
भाग I (तकनीकी-वाणिज्यिक) बोली खोलने की तिथि और समय Date & time of opening of Part I (Techno – Commercial) Bid	29 July - 2024 at 15.30 Hrs IST
संपर्क व्यक्ति Contact Person	<i>For Commercial queries:</i> Mr. Adarsh S, Mob No : 87146 30926, AM (Outsourcing Department) <i>For Technical queries:</i> Mr. Aravind Vijay, Mob. No: 81292 70895, SM (OF)



TENDER ENQUIRY NOTICE – On-board Installation and Fitment of Cargo Hold Fittings and Lashing Items in in Multi-Purpose Vessels- MPV

नोट: इस निविदा के खिलाफ उद्धृत करने से पहले, संभावित बोलीदाता से अनुरोध है कि वे निविदा जांच दस्तावेज़ (और अनुलग्नक, यदि कोई हो) को पूरी तरह से और सावधानी से पढ़ लें। निविदा के नियमों और शर्तों में विचलन अत्यधिक हतोत्साहित किया जाता है। इसलिए, निर्धारित किसी भी नियम और शर्तों, योग्यता मानदंड, ईएमडी जमा करने से छूट के लिए पात्रता, दस्तावेज़ीकरण/प्रक्रियात्मक आवश्यकताओं आदि के संबंध में स्पष्टीकरण, यदि कोई हो, के संबंध में उत्पन्न होने वाले किसी भी संदेह को संभावित बोलीदाता द्वारा बोली जमा करने से पहले निरपवाद रूप से उपरोक्त सूचित व्यक्तियों के माध्यम से अनिवार्य रूप से स्पष्ट किया जाएगा।

Note: Before quoting against this Tender, the prospective bidder is requested to go through the Tender Enquiry document (& Annexes, if any) thoroughly & carefully. Deviations to the Terms & Conditions of the Tender are highly discouraged. Therefore, any doubts arising in respect of any of the Terms & Conditions stipulated, Qualification Criteria, Eligibility for exemption from submission of EMD, clarification if any w.r.t. Documentation / Procedural requirements, etc. shall get clarified by the prospective bidder through above noted contact persons invariably before the submission of the Bid.

1. कोचीन शिपयार्ड लिमिटेड, एक प्रमुख पोत निर्माण और पोत मरम्मत उद्योग और वैश्विक पोत निर्माण के मोर्चे पर विख्यात, इच्छुक, प्रतिष्ठित, संसाधन संपन्न और वित्तीय रूप से सक्षम कंपनियों/ठेकेदारों को एकल चरण दो भाग बोलियों को प्रस्तुत करने हेतु आमंत्रित करता है।

Cochin shipyard Limited, a leading Ship Building & ship repair industry and also well known player on the global ship building front, invites interested, reputed, resourceful and financially solvent firms/contractors to submit single stage two part bids.

2. निर्धारित प्रपत्र में मुहरबंद प्रतिस्पर्धी निविदाएं निविदा जांच के अनुलग्नक में उल्लिखित नियम और शर्तों के अनुसार होनी चाहिए।

The Sealed competitive tenders in the prescribed form should be as per the terms and conditions as mentioned in the annexure to tender enquiry.

3. निविदा के कार्यक्षेत्र के विस्तार पर चर्चा करने के लिए निविदा पूर्व बैठक दिनांक **22.07.2024** को सीएसएल के योजना सम्मेलन कक्ष में पूर्वाह्न **11.00** बजे से आयोजित की जाएगी। पूर्व निविदा बैठक में भाग लेने के इच्छुक ठेकेदारों को अपने पूर्व निविदा प्रश्नों (यदि कोई हो) को दिनांक **19.07.2024** तक सकारात्मक रूप से सूचित और अग्रेषित करना चाहिए।

The pre-bid meeting will be held on 22.07.2024 at SB Conference Hall of CSL from 11.00 hrs to discuss the detail scope of work of the tender. The Contractors interested to participate in Pre-bid meeting should inform and forward their Pre-bid queries (if any) by 19.07.2024 positively.

4. पूर्व निविदा बैठक में भाग लेने के लिए सूचना और पृष्ठताछ, यदि कोई हो, तो निम्नलिखित मेल आईडी ashtal.antony@cochinshipyard.in & adarsh.s@cochinshipyard.in पर समय पर अग्रेषित की जानी चाहिए।

TENDER ENQUIRY NOTICE – On-board Installation and Fitment of Cargo Hold Fittings and Lashing Items in in Multi-Purpose Vessels- MPV

Information to participate in pre-bid meeting and queries, if any should be forwarded in time to following mail ID: ashtal.antony@cochinshipyard.in & adarsh.s@cochinshipyard.in

5. निविदाएं दो बोली प्रणाली में प्रस्तुत की जानी हैं; भाग I : तकनीकी वाणिज्यिक बोली और भाग II : सॉफ्ट कॉपी के रूप में मूल्य बोली और निर्धारित तिथि और समय पर या उससे पहले अधोहस्ताक्षरी के पास पहुंच जानी चाहिए :

The tenders are to be submitted in two bid system; **Part I : Techno Commercial Bid** and **Part II : Price Bid** as Soft copy and should reach the undersigned on or before the date and time as stipulated:

6. **MODE OF SUBMISSION OF BIDS**

- a. निविदा केवल ई-मेल के माध्यम से सॉफ्ट कॉपी में प्रस्तुत की जानी चाहिए। सीएसएल किसी अन्य प्रकार की निविदा स्वीकार नहीं करेगा।

Tender should be submitted in soft copy via E-mail only. CSL will not accept any other mode of tender.

- b. ई-मेल के विषय में स्पष्ट रूप से निविदा पृष्ठताछ संख्या और जमा करने की देय तिथि का उल्लेख होना चाहिए। मूल्य बोलियों को पासवर्ड से सुरक्षित किया जाना चाहिए और जब तक मांगा नहीं जाता तब तक पासवर्ड अग्रेषित नहीं किया जाना चाहिए।

The subject of the E mail should clearly state the tender enquiry number and due date of submission. Price Bids are to be password protected and password is not to be forwarded unless asked for.

- c. निविदा दस्तावेज़ पीडीएफ प्रारूप में प्रस्तुत किया जाना चाहिए और पीडीएफ प्रारूप से सीधे खोला जा सकता है। उपरोक्त का अनुपालन न करने वाले प्रस्तावों को बिना किसी सूचना के सरसरी तौर पर खारिज कर दिया जाएगा।

Tender Documents should be submitted in PDF Format and Directly openable from the PDF format. Offers not complying with the above shall be summarily rejected without further intimation.

- d. निविदाएं, तकनीकी – वाणिज्यिक बोली (भाग-I) और मूल्य बोली (भाग-II) अलग से ई-मेल के माध्यम से **“SB-OSD/MPV/883/2024”** विषय के साथ प्रस्तुत की जाएगी।

Tenders, Techno- commercial bid (Part-I) and Price bid(Part -II) shall be submitted separately via email , with subject as **“ SB-OSD/MPV/883/2024”** to:

- (i) ashtal.antony@cochinshipyard.in

- (ii) adarsh.s@cochinshipyard.in

प्रतिलिपि / Copy to:

- (ii) madhu.pk@cochinshipyard.in

- (iii) philip.thomas@cochinshipyard.in

7. बोलियां दिनांक 29 जुलाई- 2024 को अपराह्न 15.00 बजे या उससे पहले कोचीन शिपयार्ड लिमिटेड में प्राप्त की जाएंगी और भाग I तकनीकी – वाणिज्यिक बोली उसी दिन अपराह्न 15.30 बजे खोली जाएगी।

TENDER ENQUIRY NOTICE – On-board Installation and Fitment of Cargo Hold Fittings and Lashing Items in in Multi-Purpose Vessels- MPV

The Bids shall be received at Cochin Shipyard Ltd on or before 15.00 Hrs on 29 July - 2024 and Part I Techno-Commercial Bid will be opened at 15.30 Hrs on the same day.

8. देर से आनेवाली निविदाएं/शर्तों वाली निविदाएं सरसरी तौर पर खारिज कर दी जाएंगी।
Late tenders / tenders with conditions will be summarily rejected.
9. सीएसएल ई-मेल द्वारा भेजी गई निविदाओं के विलंब, खो जाने या प्राप्त न होने की कोई ज़िम्मेदारी नहीं लेगा।
CSL takes no responsibility for delay, loss or non-receipt of tenders sent by e-mail.
10. मूल्य बोली खोलने के लिए केवल तकनीकी रूप से योग्य बोलियों पर विचार किया जाएगा। तकनीकी पहलुओं और वाणिज्यिक शर्तों दोनों के लिए बोलियों का मूल्यांकन करने के बाद, तकनीकी-व्यावसायिक रूप से योग्य बोलीदाताओं को भाग-II

Only technically qualified bids will be considered for price bid opening. After evaluating the bids for both technical aspects and commercial terms, the techno-commercially qualified bidders will be intimated regarding the date and time of opening of Part II - Price Bid.

11. केवल तकनीकी – वाणिज्यिक बोली खोलने को अनुबंध देने के लिए प्रस्ताव की स्वीकृति के रूप में नहीं माना जा सकता है।
Merely opening of Techno-Commercial Bid cannot be construed as acceptance of offer for awarding of contract.
12. भाग I (तकनीकी-वाणिज्यिक) बोली के साथ निम्नलिखित प्रस्तुत किया जाएगा :

The following shall be submitted along with Part I (Techno-commercial) Bid:-

- i. अनुलग्नक I, II, III, IV, V,VI और परिशिष्ट –A, B & C में रखे गए पूछताछ के नियम और शर्तें, सामान्य शर्तें, तकनीकी विनिर्देश और आरेखण सहित सभी पृष्ठों पर विधिवत हस्ताक्षरित मूल निविदा दस्तावेज़।

Original tender document duly signed on all pages - including Terms & conditions of enquiry, general conditions, technical specification and drawings placed at Annexure I, II, III, IV, V,VI & Appendix- A, B & C

- ii. अनुलग्नक IV में तकनीकी वाणिज्यिक जांच सूची पूरी तरह से भरी हुई है और विधिवत हस्ताक्षरित है। विधिवत भरी हुई तकनीकी वाणिज्यिक जांच सूची प्रस्तुत न करने पर बोलियों को अस्वीकार कर दिया जाएगा।

The techno commercial Check List at Annexure IV filled up completely and duly signed. The non submission of duly filled techno commercial checklist will lead to the rejection of the bids.

- iii. गैर-मूल्य बोली प्रारूप की प्रतिलिपि (कीमत/अंकों के बिना मूल्य बोली)।

Copy of un-priced bid format (price bid WITHOUT prices/numerals)

- iv. निविदा पूछताछ नियम और शर्तों से विचलन/बहिष्करण की सूची (यदि कोई हो)।

List of deviations/exclusions from the tender enquiry terms and conditions (if any).

13. पूर्व अनुबंध अखंडता संधि / PRE CONTRACT INTEGRITY PACT

निविदा में भाग लेने वाले बोलीदाताओं को पूर्व अनुबंध अखंडता समझौते पर हस्ताक्षर करना होगा, यदि बोली 1 करोड़ रुपए से अधिक है।

TENDER ENQUIRY NOTICE – On-board Installation and Fitment of Cargo Hold Fittings and Lashing Items in in Multi-Purpose Vessels- MPV

The bidders who are participating in the tender shall sign the pre contract integrity pact, in case the bid is above Rs 1 crore.

14. एमएसएमई – विशेषाधिकार / MSME- PRIVILEGES

सीएसएल वेबसाइट (www.cochinshipyard.in) के अनुसार एमएसएमई, स्टार्ट-अप आदि से संबंधित भारत सरकार की सार्वजनिक खरीद नीति पहल इस निविदा के लिए लागू होगी।

Public procurement policy initiatives of Govt. of India, pertaining to MSME's, Start-up etc. as per CSL website (www.cochinshipyard.in) shall be applicable for this tender.

15. कोचीन शिपयार्ड लिमिटेड (सीएसएल) ने ट्रेड्स पोर्टल अर्थात आरएक्सआईएल, एम1 एक्सचेंज और इनवॉयस मार्ट में पंजीकरण कराया है। वे विक्रेता जिन्होंने ट्रेड्स पोर्टल में पंजीकरण कराया है, वे ट्रेड्स पोर्टल के ज़रिए भुगतान को संसाधित करने के लिए संबंधित निष्पादन अधिकारी को सूचना के तहत संबंधित पोर्टल में चालान अपलोड कर सकते हैं। आपूर्तिकर्ताओं से अनुरोध है कि ट्रेड्स पोर्टल में चालान अपलोड करने से पहले, जहां भी लागू हो, गुणवत्ता निरीक्षण स्थिति के संबंध में संबंधित निष्पादन अधिकारी से जांच करें।

Cochin Shipyard Limited (CSL) has registered in the **TReDS Portal viz., RXIL, M1xchange and Invoice Mart**. Those vendors who have registered in the TReDS portal may upload the invoice in the respective portal under an intimation to concerned executing officer for processing the payment through TReDS portal. Suppliers are requested to check with the concerned executing officer regarding the Quality inspection status, where ever applicable, before uploading the invoices in TReDS portal.

16. सीएसएल के पास पूरा ऑर्डर देने या ऑर्डर की मात्रा का कुछ हिस्सा देने या काम को दो या दो से अधिक फर्मों/उपठेकेदारों में विभाजित करने या किसी भी निविदा को स्वीकार या अस्वीकार करने, या निविदा खोलने की तारीख बढ़ाने, और या कुल निविदा प्रक्रिया को रद्द करने और सभी को अस्वीकार करने का अधिकार सुरक्षित है। अनुबंध प्रदान करने से पहले किसी भी समय निविदाएं। सीएसएल प्रभावित फर्म(फर्मों) के प्रति कोई दायित्व नहीं निभाएगा, सीएसएल की कार्रवाई के आधार के बारे में प्रभावित फर्म(फर्मों) को सूचित करने का कोई दायित्व नहीं होगा। बोलीदाताओं से अनुरोध है कि वे नोट करें और तदनुसार बोली लगाएं।

CSL reserves the right to place order whole or part of order quantity or split the work on two or more firms/subcontractors or to accept or reject any tender, or extend the tender opening date, and or to cancel the total tender process and reject all tenders at any time prior to award of the contract. CSL will not incur any liability to the affected firm(s), any obligation to inform the affected firm(s) of the grounds for CSL's action. Bidders are requested to note and quote accordingly.

17. मुख्य महाप्रबंधक, पोत निर्माण प्रभाग, कोचीन शिपयार्ड लिमिटेड, निविदा या उसके हिस्से को स्वीकार करने हेतु अधिकृत व्यक्ति है, जो न्यूनतम निविदा को स्वीकार करने हेतु स्वयं को बाध्य नहीं करता है और बिना कोई कारण बताए प्राप्त किसी या सभी निविदाओं को अस्वीकार करने का अधिकार सुरक्षित रखता है।



TENDER ENQUIRY NOTICE – On-board Installation and Fitment of Cargo Hold Fittings and Lashing Items in in Multi-Purpose Vessels- MPV

Chief General Manager, Ship Building Division, Cochin Shipyard Limited, is the authorized person to accept the tender or part thereof, who does not bind himself to accept the lowest tender and reserves the authority to reject any or all of the tenders received without assigning any reason.

कृते उप महाप्रबंधक / For Deputy General Manager
आउटसोर्सिंग विभाग / Outsourcing Department



ANNEXURE- I

जांच की नियम और शर्तें / TERMS & CONDITIONS OF ENQUIRY

**ONBOARD INSTALLATION AND FITMENT OF CARGO HOLD FITTINGS
AND LASHING ITEMS IN MULTI PURPOSE VESSELS**

7K MPV – 8 NO VESSELS [SH 029 – SH 036]

1. कार्य का विवरण / DESCRIPTION OF WORK

1.1. This tender enquiry pertains to the awarding of contract for Onboard Installation and Fitment of Cargo Hold Fittings and Lashing Items in Multi-Purpose Vessels 7k MPV – 8 No Vessels [SH 029 – SH 036] as per the following documents:

- 1.1.1. Cochin Shipyard Ltd - Terms and conditions (Annexure I)
- 1.1.2. Cochin Shipyard Ltd - General conditions (Annexure II)
- 1.1.3. Enquiry specification (Annexure III)
- 1.1.4. Relevant drawings and other data as enclosed.

1.2. The scope of work includes Onboard Installation and Fitment of Cargo Hold Fittings and Lashing Items in Multi-Purpose Vessels 7k MPV – 8 No Vessels [SH 029 – SH 036] in accordance with the Scope of work specified at Annex-III and drawings, delivery schedule, CSL - Terms and conditions in all respects.

1.3. **Bidders are requested to study the scope of work before submitting their offer. Clarification, if any, required may be obtained from SM (OF) before quoting.**

2. विक्रेताओं के लिए पात्रता मानदंड / QUALIFICATION CRITERIA FOR VENDORS

The Bidder should qualify the following PQ Criteria:

2.1. GENERAL

- 2.1.1. Bidder shall be a single firm.
- 2.1.2. Bidder shall not be under a declaration of ineligibility issued by Govt. of India/ State govt./Public Sector Undertakings etc. The bidder shall not have been debarred / black listed by CSL or by any of the Public Sector Undertaking or Government department etc. The declaration of eligibility at Annexure VII shall be submitted in this regard.

TENDER ENQUIRY NOTICE – On-board Installation and Fitment of Cargo Hold Fittings and Lashing Items in in Multi-Purpose Vessels- MPV

2.1.3. All the qualifying documents indicated in the tender shall be strictly in the name of bidding firm. Qualifying documents submitted in the name of any other than bidding firm will not be considered for bidding firm's qualification.

2.2. TECHNICAL EXPERIENCE

Technical pre-qualification requirement is given below:

- 2.2.1. The Bidder shall having minimum three (03) year experience in structural/ structural outfitting works in steel on ships in Ship Building area continuously or in fragments, during the past seven (07) years ending on 31st January 2024 and also, the value of works completed in a year by the firm for min Rs.10 Lakhs in the last three years.
- 2.2.2. The bidder also needs to agree, to qualify their welders to the requirement as per work allocation and scope of work.
- 2.2.3. Documents to prove credentials of the firm to undertake the subject work. eg: Details of available equipment's & facilities, Skilled / qualified Manpower, Work experience of similar job, etc. The firm has to submit the documents which validate the above mentioned Clause 2.2.1 and 2.2.2 requirements. Work order for material supply will not be considered.
- 2.2.4. The similar works experience of parent company / subsidiary / Sister Company of the Bidder shall not be considered.
- 2.2.5. CSL reserves the right to demand hardcopies of any of the above documents and any other related documents, if required. Bidders shall comply with the same.

2.3. FINANCIAL CAPABILITY

- 2.3.1. The bidder shall have an average annual financial turnover of **Rs. 21 Lakhs** during the last three years ending on 31st March 2023.
- 2.3.2. The Bidder shall enclose with its Proposal, certificate issued by Chartered Accountant with their seal and signature, stating its positive net worth, turnover and profit during the past three years. Certificate shall be as per the format placed at Appendix – B.
- 2.3.3. The applicant shall furnish a positive net worth certificate (from Chartered Accountant), to the effect that the tenderer is financially sound and has sufficient resources for security deposit / retention money and for executing the work as per schedule.

TENDER ENQUIRY NOTICE – On-board Installation and Fitment of Cargo Hold Fittings and Lashing Items in in Multi-Purpose Vessels- MPV

2.4. OTHER CONDITIONS

- 2.4.1. The bidding firm shall have key personnel having single point of contact with contract details. He/she shall have adequate and specialized experience capable of discharging their responsibilities.
- 2.4.2. The bidding firm should have valid PAN and GSTIN and details of PAN / GST Registration Number and current valid Tax Clearance Certificate shall be submitted along with the offer.
- 2.4.3. Bidder should submit duly signed compliance matrix placed at Appendix – A for technical deviation/queries if any along with the offer.
- 2.4.4. If required, the documents / certificates submitted by bidder will be verified with source directly by CSL. Misleading or false representations in the forms, statements and attachments submitted in proof of eligibility requirements will result in summarily rejection / disqualification of the submitted offer at any point of time whatever may be the status of the process. Also, the firm will not be considered for further tendering for a period of three (3) years henceforth.
- 2.4.5. The Bidder should furnish the required work-specific information and satisfactory documentary evidence such as copy of work order / agreement and a certificate from the employer for satisfactory completion of work or any other relevant document indicating completion of work shall be submitted to CSL in support of its claim of experience.
- 2.4.6. RIGHT TO VERIFICATION: CSL has the right to verify the authenticity of bidder/ documents submitted by them and/or inspect the facilities if felt necessary. Based on this CSL reserves the right to accept and reject any and all bids, which in its opinion, appears to be most advantageous to CSL.

3. प्रस्ताव की वैधता/VALIDITY OF OFFER

- 3.1. The offer shall be valid for acceptance for a period of 90 days from the date of opening of the Part-I Techno-Commercial Bid.

4. अनुबंध प्रदान करने का तरीका / METHOD OF AWARDING CONTRACT

- 4.1. Total vessels under this contract are 8 Nos MPV vessels (SH-29 - 36).
- 4.2. The category of work under the tender for vessels SH.29 - 36 is classified as follows :-
- (i) Part A - Fitment and welding of Dovetail ISO Container Sockets and Lashing D-rings.
- (ii) Part B - Fitment and welding of Flush Lashing pots.

TENDER ENQUIRY NOTICE – On-board Installation and Fitment of Cargo Hold Fittings and Lashing Items in in Multi-Purpose Vessels- MPV

- 4.3. Contract will be concluded with the Bidder qualifying to techno-Commercial conditions and emerging as L1 for each part / bidder willing to match with L1 rate.
- 4.4. Considering the limited time period available for project completion, CSL reserves the right to split order at L1 rate as per clause 4.5, 4.6 & 4.7 below.
- 4.5. **Part A :** The scope of work corresponding to 30% of total work of Part A per vessel is assured for L1 bidder. Balance 70% will be awarded in the order of 20%, 20%, 20% and 10% to other four bidders who are willing to match the L1 rate. Selection of this bidder will be in the sequence of ascending order of lowest rate quoted (L2, L3, L4....).
- 4.6. **Part B :** The scope of work corresponding to 30% of total work of Part B per vessel is assured for L1 bidder. Balance 70% will be awarded in the order of 20%, 20%, 20% and 10% to other four bidders who are willing to match the L1 rate. Selection of this bidder will be in the sequence of ascending order of lowest rate quoted (L2, L3, L4....).
- 4.7. Work distribution/ allocation based on number of firms willingness to match L1 rate is detailed below :

	Description	Approximate percentage of work distribution per vessel for Part A and Part B				
		Firm-A	Firm-B	Firm-C	Firm-D	Firm-E
Case-1	If, four firms are willing to match L1 rate.	30%	20%	20%	20%	10 %
Case-2	If, three firms are willing to match L1 rate.	40%	20%	20%	20%	-
Case-3	If, two firm are willing to match L1 rate.	40%	30%	30%	-	-
Case-4	If, only one firm is willing to match L1 rate.	60%	40%	-	-	-
Case-5	If, no firm is willing to match L1 rate.	100%	-	-	-	-

NOTE : Firm A means L1 firm, Firm B,C,D & E means L1 rate matching firm in ascending order of lowest rate quoted.

TENDER ENQUIRY NOTICE – On-board Installation and Fitment of Cargo Hold Fittings and Lashing Items in in Multi-Purpose Vessels- MPV

- 4.8. In case, if no other bidder is willing to match the L1 rate, CSL reserves the right to place order in part/ full on L1 firm or retender the requirement depending upon project schedule, priorities, etc.
- 4.9. The decision for on the same will be taken based on verification of the performance, financial capabilities, etc of L1 firm.
- 4.10. The decision for award of works as per clause 4.5 - 4.7 above will be based on experience/ performance of awarded work under this contract and financial capacity of the firm/ successful bidder. CSL's decision in this regard will be final and legally binding on the bidders.
- 4.11. **L1 will be identified separately for Part A and Part B and work will be allotted separately for part-A & part-B based on cases noted at Clause 4.7 above.**
- 4.12. CSL reserves right to reduce/ increase the percentage work or cancel the order based on the performance of work undertaking firms at site.
- 4.13. CSL reserves the right to cancel the tender at any stage without assigning any reasons whatsoever based on CSL requirement. The decision of CSL regarding the same shall be final and conclusive.

5. **कार्य की प्रगति तथा समापन की समय-सारणी/WORK PROGRESS AND SCHEDULE OF COMPLETION**

- 5.1. All Works corresponding to each vessel for Part - A should be completed within 40 days and Part - B should be completed within 28 days from the date of working area readiness at CSL/ on receipt of materials from CSL. In the case of split order, the firm should work in line with CSL requirement as per the instruction of officer-in -charge.
- 5.2. Yard has the right to change the schedules of the project to the interests of the company and the firm should be capable of adjusting the resources according to the instructions from the Yard contact person.
- 5.3. Detailed working schedule (Weekly/monthly) etc to be prepared and submitted to yard personnel. However, a detailed overall schedule, in a reasonable manner should be submitted prior to commencement of work.

6. **कार्य प्रक्रिया / WORK PROCEDURE**

- 6.1. Detailed for each category of works are mentioned in the Annexure III to the tender enquiry.
- 6.2. Necessary job instructions, drawings etc. for the work will be issued by CSL.

TENDER ENQUIRY NOTICE – On-board Installation and Fitment of Cargo Hold Fittings and Lashing Items in in Multi-Purpose Vessels- MPV

- 6.3. Contractor is to carry out the work as per the specifications / drawings supplied, and to the satisfaction of CSL.
- 6.4. Contractor should maintain the quality as per CSL Quality Standards, yard quality procedures. Inspection will be carried out during fabrication by CSL.
- 6.5. Contractor shall submit the weekly /monthly progress reports to CSL.

7. अनुबंध की वैधता / VALIDITY OF CONTRACT

- 7.1. Once the contract is awarded, the price offered and mutually agreed shall remain firm (Contract concluded price as per Annex-V) till completion of work and no escalation in rate shall be allowed by CSL on whatsoever reason thereafter.

8. निरीक्षण / INSPECTION

- 8.1. The complete work has to be carried out under the survey of ship classification society / owner / CSL.

9. बोलियां जमा करने के लिए दिशानिर्देश / GUIDELINES FOR SUBMISSION OF BIDS

9.1. Technical Bid (Part –I)

- 9.1.1. The technical bid as specified in the scope of work (Annexure III) shall be submitted in E-mail.
- 9.1.2. **The following shall be submitted along with technical Bid, failing which the bid may be summarily rejected :-**
 - 9.1.2.1. Original tender document general Terms & conditions and technical specifications placed at Annexure I, II & III duly signed on all pages.
 - 9.1.2.2. The commercial Check List at Annexure IV filled up completely and duly signed
 - 9.1.2.3. Copy of un-priced bid format of each category of works at Annexure V.
 - 9.1.2.4. As per Govt. of India guidelines, Integrity pact (IP) should be signed for all contracts above Rs. One Crore. Accordingly IP should be signed and forwarded along with the offer.
 - 9.1.2.5. The declaration of eligibility at Annexure VII
 - 9.1.2.6. All other documents relevant to this tender.
- 9.1.3. **The non submission of duly filled commercial checklist will lead to the rejection of the bids.**

TENDER ENQUIRY NOTICE – On-board Installation and Fitment of Cargo Hold Fittings and Lashing Items in in Multi-Purpose Vessels- MPV

9.2. Price Bid (Part-II)

9.2.1. The bid shall be comprehensive of the nature for the Onboard Installation and Fitment of Cargo Hold Fittings and Lashing Items in Multi-Purpose Vessels shall be inclusive for all the applicable charges envisaged under the scope of the contractor as specified in the technical specification Annexure III.

9.2.2. L1 will be identified separately for Part A and Part B.

9.2.3. Bidders can to quote Part- A or Part-B or both.

9.2.4. Bidders shall quote total amount in figures and in words. Corrections and additions if any must be attested/ duly signed by the bidder. In the case of error in multiplication/addition in amount calculated, the rate quoted will be considered as correct and the amount will be calculated accordingly. Conditional rebates & discounts, incomplete/ ambiguous offer will be rejected.

9.2.5. The price bid shall be all inclusive of scope of contractor on lump sum basis and any rates on variable basis will not be accepted within the price bid and thereafter throughout the period of the contract. Any variable rates if deemed inevitable and applicable only in special cases/situations (not in the normal course of execution of contract) will only be considered for mutual agreement.

9.2.6. Price Bid Format: The price bids shall be prepared as per the format given in Annexure V to the enquiry. The bidder must quote all line items as per price bid format any failure in this regard will lead to the rejection of bid.

9.2.7. Rates of individual line items for the overall L1 is considered as L1 rate for each part (Part A & Part B) of Price bid irrespective of lower rates in case of the line items within the part of other bidders.

9.2.8. Currency: The price bids shall be prepared in Indian National Rupees for all bidders.

9.2.9. As per tender condition, the price bid which were not opened will not be returned back at any reason.

9.2.10. The bids which are not conforming above requirements shall be summarily rejected without any further notice.

10. असामान्य रूप से कम उद्धृत दरें /ABNORMALLY LOW QUOTED RATES:

In case the price of L-1 Bidder is found to be unreasonably low and/ or bidder expresses desire to withdraw from the tender after opening of price bid, then tender will be cancelled and suitable penal action as per CSL procedure shall be taken against the firm.

TENDER ENQUIRY NOTICE – On-board Installation and Fitment of Cargo Hold Fittings and Lashing Items in in Multi-Purpose Vessels- MPV

11. कर / TAXES

11.1. GST shall be applicable extra on the prescribed work. Bidders should indicate the applicable GST percentage and HSN code of the category in the offer. Bidders are also requested to furnish the following details in the invoice/Bill.

11.1.1. Applicable rate of GST/SAC Code

11.1.2. Firms GST Reg. NO

11.1.3. Service accounting code (SAC) as prescribed by statutory authorities.

11.1.4. GST Reg. No. of Cochin Shipyard Ltd (**32AAACC6905B1ZD**).

11.2. Any new tax/duty that may be made effective by the government for this work and paid by the contractor shall be reimbursed on production of documentary evidence.

12. भुगतान की शर्तें / PAYMENT TERMS

12.1. Payment will be released in 5 stages (Both Part A & Part B), for the following work completion stages and on certification by the Officer-in-charge.

Stage -1: 30% of the work order value on completion of 70% of fit-up completion or 40% of NDT completion, whichever is earlier, against the furnishing of PBG as per the tender clause.

Stage -2: 10% of work order value on completion of 100% fit-up completion.

Stage -3: 10% of work order value on 50% work completion, including all NDTs applicable.

Stage -4: 25% of work order value on 75% work completion, including all NDTs applicable.

Stage -5: 25% of work order value on 100% work completion, including all NDTs applicable.

12.2. All claims for payment for the work/additional work shall be submitted by the sub-contractor within one month of completion of work.

12.3. An invoice upload facility by vendor is established through the Vendor Invoice Management (VIM) Portal is currently available for supply as well as service vendors including subcontractors so as to facilitate transparency and timely payment. The portal can be accessed at: <https://apps.cochinshipyard.in:446/vim/Home.jsp>

12.4. The same can also be accessed via Cochin Shipyard Website (<https://cochinshipyard.in>) as below;

12.5. Path: Cochin Shipyard Website --> Related Links --> Vendor Payment Info

12.6. All invoices above 10 Lakhs (including GST) are required to be digitally signed by the vendors and uploaded in VIM portal. The direct submission of invoices value above 10

TENDER ENQUIRY NOTICE – On-board Installation and Fitment of Cargo Hold Fittings and Lashing Items in in Multi-Purpose Vessels- MPV

Lakhs will not be accepted. Once the invoices are digitally signed and uploaded, there is no need to submit the hard copy for processing the payment.

- 12.7. Service Acknowledge Number (SAN) to be obtained from the Executing Officer at the time of certification of Work Completion Certificate (WCC) for the above process.
- 12.8. The invoice can be tracked using the generated Invoice Tracking Number till the payment.
- 12.9. Payment will be made by RTGS/NEFT to the account of contractor. The name of the bank, branch, A/C No., IFSC code & other particulars shall be furnished by the contractor in the proforma of CSL.

13. प्रतिभूति जमा / SECURITY DEPOSIT

- 13.1. The successful tenderer shall remit 5 % of the value of the contract as security deposit within 15 days of receipt of the work order. This amount has to be remitted by way of demand draft or bank guarantee (in approved proforma of CSL) from any of the nationalized banks/ Scheduled Indian Bank, valid till the satisfactory completion of the entire work. The Security Deposit will be released after satisfactory completion of the contract. The Security Deposit will not bear any interest.

15. निष्पादन गारंटी / PERFORMANCE GUARANTEE

- 14.1. The complete work carried out by the contractor shall be guaranteed against performance of work and/or poor workmanship for a period of one year from the date of completion of work. The cost for rectifying the damages or loss or rework due to defects in execution of work as above shall be deducted from the contractor.
- 14.2. Towards this, a performance guarantee equivalent to 5 % of the value of the contract to be furnished by the contractor before the submission of first invoice, by way of a bank guarantee (in approved proforma of CSL) from a nationalized bank / Scheduled Indian Bank valid till the expiry of the guarantee period. (Payment will be released only on submission of PBG)
- 14.3. PBG will be returned to the Contractor after one year from the date of completion of work on certification of nil liability to CSL by Officer-in charge.
- 14.4. Performance Guarantee is applicable for all bidders irrespective of MSME/NSIC registration for necessary coverage under the performance guarantee clause.

15. परिसमापन क्षतिपूर्ति / LIQUIDATED DAMAGES

15.1. The progress of work will be monitored against the mutually agreed detailed schedule referred in clause. Liquidated damages for delays in execution of the work envisaged as per this order, for any reason other than force majeure conditions, will be recovered at the rate of two percent (2%) of the total contract value of part A / part B per week or part thereof, subject to a maximum of ten (10) percent of the total contract value of part A / part B.

16. आदेश रद्द करना और जोखिम अनुबंध / CANCELLATION OF ORDER AND RISK CONTRACTING

16.1. In the event the contractor fails to complete the work promptly and satisfactorily as per the terms of the order, and if the work is delayed beyond the agreed schedule, CSL, without prejudice, reserves the right to cancel the order and get the work done at contractor's cost and the expenditure so incurred including any damage or loss will be recovered from him and the Security Deposit furnished by him is liable to be forfeited either in whole or in part.

16.2. In addition to above tender holiday will be imposed against the firm as per discretion of CSL.

17. कार्मिकों की सुरक्षा और प्राथमिक चिकित्सा / SAFETY OF PERSONNEL AND FIRST AID

17.1. The contractor shall be entirely responsible for the safety of all the personnel employed by him on the work. In this regard, he may adopt all the required safety measures and strictly comply with the safety regulations in force.

17.2. The Contractor may arrange to suitably insure all his workmen/ other personnel in this regard. CSL will not be responsible for any injury or illness to the Contractor's workmen/other personnel during execution of the works due to whatsoever reasons.

17.3. In this regard, the Contractor will have to fully indemnify CSL against any claims made by his workmen/other personnel.

17.4. The Contractor shall provide and maintain so as to be readily accessible during all working hours, a first aid box with prescribed contents at every place where he employs contract labour for executing the works.

TENDER ENQUIRY NOTICE – On-board Installation and Fitment of Cargo Hold Fittings and Lashing Items in in Multi-Purpose Vessels- MPV

18. अप्रत्याशित घटना / FORCE MAJEURE

- 18.1. Should failure in performance of any part of this contract arise from war, insurrection, restraint imposed by Government act or legislation of other statutory authority, from explosion, riot, legal lock-out, flood, fire, act of Govt. or any inevitable or unforeseen event beyond human control which will be construed as a reasonable ground for extension of time, CSL may allow such additional time as is mutually agreed to be justified by the circumstances of the case.
- 18.2. The occurrence / cessation of force majeure situation have to be informed with documentary evidence within 15days from the date of occurrence / cessation.

19. मध्यस्थता / ARBITRATION

- 19.1. Any disputes arising during the currency of the contract shall, in the first instance be settled by mutual discussions and negotiations. The results of such resolution of dispute shall be incorporated as an amendment to the contract, failing which the parties can resort to arbitration.
- 19.2. If any dispute, disagreement or question arising out of or relating to or in consequence of the contract, or to its fulfillment, or the validity of enforcement thereof, cannot be settled mutually or the settlement of which is not herein Specifically provided for, then the dispute shall within thirty days from the date either party informs the other in writing that such disputes, disagreement exists, be referred to arbitration. The arbitrators shall be appointed and the arbitration proceedings shall be conducted in accordance with and subject to the Arbitration and Conciliation Act, 1996 (No. 26 of 1996) as amended from time to time and the decision of the Arbitrators shall be final and binding on the parties hereto. The arbitration will be done by a Board comprising one officer nominated by each party, and a mutually agreed Umpire. Each party shall bear its own cost of preparing and presenting its case. The cost of arbitration shall be shared equally by the parties unless the award provides otherwise. The enforcement of the award shall be governed by the rules and procedures in force in the State in which it is to be executed. Performance under this Contract shall however, continue during arbitration proceedings and no payment due or payable by the parties hereto shall be withheld unless any such payment is or forms a part of the subject matter of arbitration proceedings.
- 19.3. In case of disputes, the same will be subjected to the jurisdiction of courts at Ernakulam, Kerala, India only.

TENDER ENQUIRY NOTICE – On-board Installation and Fitment of Cargo Hold Fittings and Lashing Items in in Multi-Purpose Vessels- MPV

20. क्षेत्राधिकार / JURISDICTION

20.1. All questions, disputes or differences arising under/out of or in connection with this contract shall be subject to the jurisdiction of the Courts in Cochin.

21. श्रम कानून और विनियम /LABOUR LAWS AND REGULATIONS

21.1. The Contractor shall undertake and execute the work with contract Labour only after taking license from the appropriate authority under the Contract Labour (Regulation & Abolition) Act 1970.

21.2. The Contractor shall observe and comply with the provisions of all labour and industrial laws and enactments and shall comply with and implement the provisions of the Factories Act, 1948, `Employees Provident Funds & Miscellaneous Provisions Act, 1952, Employees State Insurance Act, Payment of Gratuity Act, minimum Wages Act, Payment of Bonus Act, Contract Labour (Regulation and Abolition) Act and all other enactments as are applicable to him and his workmen employed by him. The Contractor shall inform CSL his license number from the Central Labour Commissioner.

21.3. All contract workmen, except those exempted under the respective Acts, shall necessarily be insured under the ESI scheme and be made members of the EPF Scheme from the day of their engagement as contract workmen in the Company. All such insured contract workmen should carry with them their ESI Identity Card for verification by the authorities. No contract workmen without a valid ESI Identity Card for verification by the authorities will be permitted to work in the company.

21.4. The Contractor shall submit the Labour Reports>Returns as required by the Company from time to time in respect of their workmen in standard format to the concerned contracting officer so as to enable the same to reach Personnel Department by the 5th of every month. Delayed submission of the same shall attract penal interest /damages at the rate as levied by the respective authorities under the relevant Acts.

21.5. The Contractor shall maintain the records viz. Muster Roll, Acquaintance Roll with full details, Account books etc., in original. These are required for inspection by the concerned authorities under each scheme.

21.6. If the Contractor fails to pay any contributions, charges or other amounts payable under any of the aforementioned provisions of law, CSL shall deduct or adjust amounts equivalent to such contribution, charges or amounts from amount payable to him by CSL, including any deposit or amounts payable against bills and make payments on his

TENDER ENQUIRY NOTICE – On-board Installation and Fitment of Cargo Hold Fittings and Lashing Items in in Multi-Purpose Vessels- MPV

account to the appropriate authority. He shall not be entitled to question or challenge such deductions, adjustments or payment made by CSL.

21.7. Any other amount payable under any law or in respect of any person employed by the Contractor, if not paid by him, shall be deducted or adjusted by CSL out of any amount payable to the Contractor including any Security Receipt and paid ever or withheld for payment by CSL.

21.8. The Contractor shall be fully responsible for the conduct and discipline of the workmen employed by him in the Company premises. If such workmen commit any misconduct or criminal act inside the Company, the Contractor shall take appropriate action against such workmen. The contractor shall abide by the instructions/ guidelines issued by the Company for maintenance of discipline and good conduct among the workmen employed by him.

21.9. All person who are engaged for various works in CSL either directly or through contractors, should produce the following documents prior to issuing their entry passes:

21.10. Passport/attested copy of passport with photo and address particulars. OR

21.11. Police clearance certificate with photo and address particulars. (Police clearance certificate to the effect that the concerned person is staying in the area of jurisdiction of the certificate issuing Police Station and that the person is not involved in any criminal offences as per the records available therein.)

21.12. Application and Declaration for enrolling under Employees Provident Fund and ESI Scheme- 3 individual passport size photographs and two copies of family photographs of the members.

21.13. **Contractors are requested to familiarize themselves with the labour rules & regulations prevailing in CSL including the labour wage pattern of contract labour as per the settlement between the trade unions & contractors.**

22. आईएमएस दिशानिर्देश /IMS GUIDELINES

22.1. CSL has implemented an Integrated Management System (IMS) consisting of Environmental Management system (EMS), Occupational Health and Safety Management System (OHSMS) and the Quality Management System (QMS) within the yard. As part of IMS, subcontractors shall comply with the following measures related to the Quality, Health, and Safety & Environment (QHSE) policy of CSL.

22.1.1. Meeting or exceeding customer requirements.

22.1.2. Assuring quality of the products and service.

TENDER ENQUIRY NOTICE – On-board Installation and Fitment of Cargo Hold Fittings and Lashing Items in in Multi-Purpose Vessels- MPV

- 22.1.3. Preventing occupational ill health & injuries.
- 22.1.4. Ensuring safe work sites.
- 22.1.5. Conserving natural resources.
- 22.1.6. Preventing / minimizing air, water & land pollution.
- 22.1.7. Handling and disposal of Hazardous wastes safely.
- 22.1.8. Complying with statutory & regulatory and other requirements.
- 22.1.9. Developing skills and motivating employees.
- 22.2. Occupational Health, safety & Environmental requirements of CSL shall also include the following.
- 22.3. The contractor (or a sub-contractor performing work on behalf of the contractor) is deemed to comply with the Occupational health, safety and environmental policy of the company and also to all operational controls/standard operating procedures and shall undertake the work in total compliance with the requirements of the established Integrated Management System (IMS) of the company.
- 22.4. The Contractor shall undertake the work in total compliance with all applicable legal/statutory requirements related to occupational health, safety and environment effective in the state of Kerala.
- 22.5. It is the sole responsibility of the contractor to assure that any sub-contractor/s who shall perform works in company lands/facilities/worksites on behalf of the contractor, is also following all requirements related to the Integrated Management System of the company and the health/safety/environmental Rules effective in the state.
- 22.6. The contractor shall provide/implement and operate/practice all occupational health, safety and environmental management measures/facilities, for their period of contract, in their activities/at their work sites, which shall be required according to the IMS of the company or that required by the health/safety/environmental Rules established and effective in the state, at their own cost.
- 22.7. If any contractor failed to comply with or violated any clauses/requirements of occupational health, safety and environmental Rules effective in the state, in their activities or at work sites and the same shall be exposed to the government or any competent authorities upon inspections, the contractor shall be solely responsible for all liabilities caused by his/her action and shall be responsible for paying the penalty and taking stipulated corrective actions insisted by the authorities within the specified time, at their own cost. Any liability to the company in this regard needs to be compensated by the contractor.

TENDER ENQUIRY NOTICE – On-board Installation and Fitment of Cargo Hold Fittings and Lashing Items in in Multi-Purpose Vessels- MPV

22.8. Upon completion of the work, contractor shall clear the area and shall not leave any Occupational health/safety/environmental liabilities to the company, from their activities at the worksites.

22.9. Any clarification related to IMS requirements of the yard, may be obtained by the contractor from the DGM (OF) or the authorized representative of the contract, prior to the commencement of work.

23. बिजली नियम और विनियमन / ELECTRICITY RULES AND REGULATION

23.1. The contractor shall adhere to the various rules in respect of electrical installation as per the Indian Electricity Rules and Regulations and Electrical Inspectorate Standards in order to make sure that men and materials are safe from hazards.

24. गोपनीयता खंड / SECRECY CLAUSE

24.1. The CONTRACTOR shall be responsible to ensure that all persons employed by them in the execution of any work in connection with this contract are aware of the provisions of the official secrets act 1923 and to comply with the same. The CONTRACTOR shall also ensure secrecy of design, construction, equipment and completion of the vessel. Any information provided to you under this contract is to be treated as strictly confidential and is not to be disclosed to any person or persons not concerned therewith.

24.2. All documents under this Contract transferred between the parties shall be treated as UNCLASSIFIED unless explicitly marked.

24.3. The CONTRACTOR shall ensure that their organization, suppliers/ installation agency/test and trials teams etc shall not communicate for use in advertising, publicity, sales release or in any other medium, system details, photographs and reproduction of equipment and their fitment on board.

24.4. SECRECY, Titles: Maps, layouts and photographs of the unit/plant including its surrounding regions showing vital installation for national security of CSL country shall not be published or disclosed to the third parties or taken out of the country without prior written approval of the CSL and upon execution of confidentiality agreements satisfactory to the CSL with such third parties prior to disclosure.

25. HEALTH, SAFETY & ENVIRONMENT CONTRACT GUIDELINES FOR OEMS /TURNKEY JOBS / SUB CONTRACT WORKS INSIDE CSL

INTRODUCTION

- 25.1. CSL is the largest public sector shipyard in India in terms of dock capacity, and caters to clients engaged in the defence sector in India and clients engaged in the commercial sector worldwide.
- 25.2. CSL is committed to provide safe and healthy work environment for the prevention of work- related injury and ill health by following the best practices in safety. CSL is certified Occupational Health and Safety management System and Environmental Management system under ISO standards/international standard.
- 25.3. Many of the works of CSL at various sites are executed by the sub-contractors. During these works, sub-contractors personnel are likely to be exposed to different types of hazards. Similarly unsafe acts of contractor’s personnel may create hazards for CSL staff or workmen of other contractors working at the site. Such unsafe acts may also pose danger to the existing installations and even to members of public.
- 25.4. CSL ensures that the requirements of its HSE Management System are conveyed by contractors and their workers. This guide is prepared to facilitate safe working during execution of contract works. The General guide lines and HSE requirements are given below for compliance in CSL.

GENERAL GUIDELINES

- 25.5. OEMs/Turnkey jobs /Contractors are selected to work inside the CSL based on their track record.
- 25.6. Along with the contract order/Registration, a copy of the HSE Safety Handbook (CSL/QMS/S&F/SOP 02 – Refer CSL Website) of CSL is given to all contractors. The details of all HSE requirements to be followed in CSL for the various types of work are detailed in the hand book. The OEMs/Turnkey jobs /Contractors shall go through all the details and strictly follow the relevant HSE guidelines for their work. In case of any doubt the same shall be clarified from Chief Safety Officer (CSO). Being ignorant of these HSE requirements will not be treated as an excuse for any HSE violations during course of work.
- 25.7. OEMs/Turnkey jobs /Contractors workmen are given a multilingual HSE induction and Emergency Response training. The individual passes for contractors and their workers are issued only after successful completion of this training. The passes are revalidated every year after successful completion of refresher training. Training requirements of

TENDER ENQUIRY NOTICE – On-board Installation and Fitment of Cargo Hold Fittings and Lashing Items in in Multi-Purpose Vessels- MPV

other roles of the subcontractor's staff shall be complied as per the CSL requirements time to time.

- 25.8. Before start of any work, the CSL officer in charge explains the scope of work and the safety precautions, hazards, PPE usage as per PPE matrix of CSL, Work Instructions, SOPs, Emergency responses to the contractor and his workers. Only trained worker with necessary skills are allowed to work as per the requirement. Necessary PPEs for the work are to be arranged by the contractor.
- 25.9. Workmen shall have Cotton coverall with identifiable logo on the dress. Supervisors, fire watch man if required, safety staff and other workforce shall be deployed as per CSL guide lines.
- 25.10. The site work supervisor of the OEMs/Turnkey jobs /Contractors shall be ensured that works are being carried out by CSL HSE requirements on daily basis and till the completion of works. The safe start and safe end requirements shall be verified by the site work supervisor on daily basis.
- 25.11. OEMs/Turnkey jobs /Contractors HSE performance will be evaluated on HSE matters as per the CSL policies time to time.
- 25.12. During the course of work if any HSE violation is noticed the same is dealt as per the Rewards and Reprimand (R&R) Policy of CSL.
- 25.13. HSE Plan to be submitted to S&F Dept while commencing the work in CSL and shall be resubmitted in every year.

HSE REQUIREMENTS

- 25.14. The OEMs/Turnkey jobs /Contractors shall take all safety precautions during the execution of awarded work and shall maintain and leave the site safe at all times. At the end of each working day and at all times when the work is temporarily suspended, he shall ensure that all materials, equipment and facilities will not, cause damage to existing property, personal injury or interfere with the other works of the project or Station.
- 25.15. The OEMs/Turnkey jobs /Contractors shall provide and maintain all type of lights, guards, fencing, warning signs, caution boards and other safety measures for vigilance as and where necessary or as required by the CSL officer-in-charge or Safety staff. The caution boards shall also have appropriate symbols.
- 25.16. Where Permit to work (PTW) is required, the work has not started without obtaining the necessary permit and the PTW requirements are followed strictly throughout the work.
- 25.17. For Project specific or non-routine work on the existing installations, separate Job Safety Assessment (JSA) is to be prepared by the contractor, cleared by the Dept in charge and

TENDER ENQUIRY NOTICE – On-board Installation and Fitment of Cargo Hold Fittings and Lashing Items in in Multi-Purpose Vessels- MPV

approval obtained from CSO before start of work. The work shall be executed through Notification Control Procedure (NCS).

- 25.18. A separate HSE plan will be required for the new projects in the yard or any turnkey projects. It shall be in line with CSL HSE requirements and same shall be routed through respective S&F dept and approved by respective HOD.
- 25.19. OEMs/Turnkey jobs /Contractors shall hold toolbox talks with his workers on daily basis to convey matters regarding the Safety aspects of the work.
- 25.20. The OEMs/Turnkey jobs /Contractors shall plan his operations so as to avoid interference with other Departmental works and other Sub-Contractors at the site. In case of any interference, requires, coordination shall be sought by the contractor from the Department for safe and smooth execution of work. This shall be done through CSL executing officer.
- 25.21. The OEMs/Turnkey jobs /Contractors shall at all times keep their work spot, site office and surroundings clean and tidy from rubbish, scrap, surplus materials and unwanted tools and equipment. Welding cables, hoses and electrical cables shall be so routed as to allow safe way to all concerned.
- 25.22. All waste generated in course of the work shall be segregated as per the yard requirements and shall be disposed at the respective collection pallets / points of the work areas as the case may be. Any kind of pollution made by the subcontractor shall attract the reprimand proceedings.
- 25.23. All necessary precautions shall be taken to prevent outbreak of fires at the work site. Adequate provisions shall be made to prevent the possibility of fires and ensure the availability of fire extinguishers at site.
- 25.24. The OEMs/Turnkey jobs /Contractors shall be held responsible for non-compliance of any of the safety measures and delays, implications, injuries, fatalities and compensation arising out of such situations of incidents including statutory obligations.

26. सामान्य शर्ते / GENERAL CONDITIONS

- 26.1. Quality of workmanship shall conform to the specification/ standards laid down by CSL
- 26.2. CSL reserves the right to award the work to more than one contractor or to take over partially or fully the work depending upon the scheduled requirements.
- 26.3. Compliance of all statutory safety requirements and other safety rules stipulated by CSL and other applicable statutory bodies shall be the responsibility of the Contractor while working at CSL premises. The Contractor should ensure that their workmen and staff are

TENDER ENQUIRY NOTICE – On-board Installation and Fitment of Cargo Hold Fittings and Lashing Items in in Multi-Purpose Vessels- MPV

adequately covered under Insurance.

- 26.4. Damages caused to the Shipyard properties/tools/accessories should be rectified by the Contractor at his cost or proportional recoveries will be made from the contractor while passing their bills for payment.
- 26.5. Cochin Shipyard Limited reserves the right to terminate the Contract at short notice in case the Contractor's performance is found not satisfactory with regard to progress of work, quality, time factor, labour dispute with their workers, poor safety records etc., and other contractual obligations. No claim whatsoever will be entertained by Cochin Shipyard Limited on this account.
- 26.6. The Contractor shall have to engage men on round the clock basis and also on Sundays and holidays, if required. Work has to be completed to the satisfaction of Cochin Shipyard representative deputed for the job. The job should be completed at the time specified by the representative deputed for the job for each stage of work.
- 26.7. The Contractor shall indemnify CSL and CSL's personnel against any claims arising out of accidents or injuries to workmen or other persons or damage to other property which may arise during the execution of the contract or from breach of any Law or Regulation prior to delivery and acceptance of the items at CSL.
- 26.8. It is also to be understood by the Contractor that Cochin Shipyard Limited does not bind itself to give the Contractor any regular or specific quantity or area of work and it shall be done at the sole discretion of CSL depending on the prevailing site conditions and other limiting factors and no claim on this account from the contractor shall be entertained.
- 26.9. The Contractor shall also be governed by the General Conditions of Contract of CSL, General Safety Rules and other relevant labour laws.
- 26.10. The contractor shall arrange to collect and clean up every day all waste, scraps; debris, etc. generated by the work men while working on-board the vessel and other locations and dispose the same suitably at his cost to the full satisfaction of CSL. In case any failure on his part to comply with this requirement, CSL will arrange the required cleaning entirely at the contractors cost.
- 26.11. The upper age limit of all workers and supervisors employed by the contractor and those contractors who do or supervise the job themselves shall be as per the prevailing rules of CSL.
- 26.12. Chief General Manager (SB) or his authorized representative will be the Officer-in-charge of this Contract.

TENDER ENQUIRY NOTICE – On-board Installation and Fitment of Cargo Hold Fittings and Lashing Items in in Multi-Purpose Vessels- MPV

- 26.13. Withdrawal of the quotation after it is accepted or failure to make contract execution within the stipulated completion period will entail cancellation of the order and forfeiture of EMD/ Security Deposit, if any/ and or risk purchase.
- 26.14. Subcontracting to other vendors shall be only after written intimation and approval of competent CSL authorities. Vendor shall not delegate or subcontract any of its obligations under the agreement without CSL's written consent. Vendor will remain liable for all subcontracted obligations and all acts or omissions of its subcontractors.
- 26.15. The procedures of work, standard operating procedures of work including documents like welding procedure specifications developed by CSL are intellectual property of CSL. Vendors shall not use or copy the procedure in any format without the written consent of competent authorities of CSL.
- 26.16. Vendor shall return the CSL resources to CSL immediately after provision of all deliverables and services or any termination of the agreement.
- 26.17. Conditional discounts, if any, will not be reckoned for tender evaluation/comparison purposes. However the same will be considered at the time of placement of purchase order if the firm turns out to be lowest bidder.

27. **अधिलेखन और सुधार / OVERWRITING & CORRECTIONS**

- 27.1. Tenders shall be free from overwriting or erasures. Corrections and additions, if any, shall be duly attested and a separate list of such corrections shall be attached with the offer.)
- 27.2. All terms and conditions, other than those mentioned above, contained in the Enquiry specification and drawings (Annexure I), Cochin Shipyard Ltd - General Terms and conditions (Annexure II) and other annexure pertaining to this tender shall also be attested by the bidder as a token of acceptance.
- 27.3. CSL reserves the right to reject any or all bids without assigning any reasons whatsoever and or based on the past unsatisfactory performance by the bidders at CSL/other PSE's/Government Departments. After issuing the work order, CSL reserves the right to terminate the contractor if the performance of the contractor is not found satisfactory. The decision of CSL regarding the same shall be final and conclusive.

कृते उप महाप्रबंधक / For Deputy General Manager
आउटसोर्सिंग विभाग / Outsourcing Department

ANNEXURE-II

कोचीन शिपयार्ड लिमिटेड / COCHIN SHIPYARD LIMITED
कोच्ची / KOCHI-682015

आउटसोर्सिंग विभाग / OUTSOURCING DEPARTMENT

सामान्य शर्तें / GENERAL CONDITIONS

1. The complete work to be carried out with the highest degree of workmanship under the inspection of CSL, Classification Society (when specifically indicated in the technical specifications), Ship owner, or any other agency nominated by the Shipyard.
2. Any minor modifications, resulting from the change in statutory regulations prevailing at the time of final inspection of work by Classification Society, to be carried out by the Contractor free of cost. In case of rework/modification/additional work, written consent is to be obtained from the Officer-in-charge before commencement of the work.
3. Contractor shall carry out the complete work in accordance with Shipyard's approved drawings. Any minor modifications from drawing or any other work or supply of material, which is not specified hereunder, but is considered incidental and essential for the successful completion of the job shall be carried out by the Contractor without any additional charge.
4. Contractor shall execute, during or after completion of the work, any minor job connected with the work, should it be considered necessary by Shipyard and/or Classification Society
5. The contractor shall be responsible for any damage caused to the material supplied by CSL. Compensation with penalty for damage or loss of the item will be recovered from the Contractor, in the event of loss or damage.
6. Contractors are required to work round the clock / Sundays/ holidays as per the requirement of concerned department in order to complete the work in time.
7. Any particulars/literature/information/certificates required by the Shipyard in connection with the work is to be forwarded free of cost.
8. All correspondence with the Shipyard to be in English language. All documents and plans to be in English language and in metric units.

कृते उप महाप्रबंधक / For Deputy General Manager
आउटसोर्सिंग विभाग / Outsourcing Department

ANNEXURE III

TECHNICAL SPECIFICATION

ONBOARD INSTALLATION AND FITMENT OF CARGO HOLD FITTINGS

AND LASHING ITEMS IN MULTI PURPOSE VESSELS

7K MPV – 8 NO VESSELS [SH 029 – SH 036]

1. INTRODUCTION

Cochin Shipyard Ltd (Yard) is constructing 08 numbers of HS ECO FREIGHTER 7000 DWT VESSELS (MPV) with yard numbers SH 029-036 for M/s HS SERVICE GMBH & CO.KG, Germany. Yard intends to outsource Onboard Installation and Fitment of Cargo Hold Fittings and Lashing Items in Multi-Purpose Vessels 7k MPV – 8 No Vessels [SH 029 – SH 036]. Each vessel has one cargo hold approximately spanning 81 m in length and 13.2 m in breadth and is closed by 12 pontoon type hatch covers. In addition to the hatch covers, the vessel has 6 tween deck panels.

2. LIST OF ITEMS FOR INSTALLATION

- 2.1. Lashing D-rings on main-deck hatch cover – 192/vessel
- 2.2. Lashing D-rings on main-deck for timber lashing – 172/vessel
- 2.3. Dovetail ISO container fittings on hatch cover – 240/ Vessel
- 2.4. Flush Lashing pots inside cargo hold – 244/vessel

3. SCOPE OF WORK

3.1. PART A : DOVETAIL CONTAINER SOCKET AND LASHING D-RINGS – TOTAL 604 NOS.

- a) Items to be collected as per list mentioned above/ drawings/ MLFs/ BOMs.
- b) D-rings, dovetail container sockets etc. to be fitted in block stage itself, prior to blasting and painting of the same blocks.
- c) During cutting for these sockets etc., extreme care to be given and proper protection to be given, so that paint is not damaged at other locations inside and outside the compartment.

TENDER ENQUIRY NOTICE – On-board Installation and Fitment of Cargo Hold Fittings and Lashing Items in in Multi-Purpose Vessels- MPV

- d) Make sure that, all the dimensions are matching prior to welding and post welded conditions, as per drawings.
- e) Qualified welders to the requirement to be employed.
- f) Testing to be done as applicable.

3.2. PART-B: FLUSH LASHING POTS - TOTAL 244 NOS.

- a) Items to be collected as per list mentioned above/ drawings/ MLFs/ BOMs.
- b) Flush lashing pots to be fitted in block stage itself, prior to blasting and painting of the same blocks.
- c) During cutting for these sockets etc., extreme care to be given and proper protection to be given, so that paint is not damaged at other locations inside and outside the compartment.
- d) Make sure that, all the dimensions are matching prior to welding and post welded conditions, as per drawings.
- e) Qualified welders to the requirement to be employed.
- f) Testing to be done as applicable.

4. OTHER RESPONSIBILITIES OF THE OUTSOURCED FIRM

- 4.1. All the related items fitment, welding and survey to be completed to the complete satisfaction of CSL QC, Owner and Class surveyors.
- 4.2. Qualified welders to the requirement to be employed.
- 4.3. Cutting and welding gases and electrodes/ welding wires will be provided by CSL. All other consumables will be under the scope of contractor.
- 4.4. Testing to be done as applicable.
- 4.5. All the required tools and tackles (tested ones) to be available with the contractor for lifting and locking purposes. Cranes will be provided by CSL.
- 4.6. Extreme care to be given while doing hot work. Adjacent area paint damage to be minimized.
- 4.7. Dedicated supervisor/ site-in-charge till the completion of the project.

TENDER ENQUIRY NOTICE – On-board Installation and Fitment of Cargo Hold Fittings and Lashing Items in in Multi-Purpose Vessels- MPV

5. SCOPE OF CSL

- 5.1. The design & supply of materials for Dovetail container socket, Lashing D-Rings and Flush Lashing Pots for the mentioned scope of work.
- 5.2. Only Welding wires and welding/ cutting gases will be supplied by CSL at centralized points.
- 5.3. Providing of MLF, Yard plan, drawing, key plan, and CSL quality standards etc.
- 5.4. Power supply, Water, compressed air (at available pressure) and cutting gases at centralized points.
- 5.5. Services of CSL cranes and forklifts will be provided subject to availability.
- 5.6. Staging above 3m height.

6. REFERENCE DRAWINGS

- 6.1. General Arrangement – Hatch covers by supplier
- 6.2. General Arrangement HDL - P22003-001-1E
- 6.3. General Arrangement TDL - P22003-010D
- 6.4. HATCHCOVER PLAN - 7000MPP-131-001
- 6.5. TWEENDECK PANEL / GRAINBULKHEAD PLAN - 7000MPP-131-002
- 6.6. CARGO HOLD ARRANGEMENT - 7000MPP-100-401-B
- 6.7. ARRANGEMENT OF TWIST LOCK POCKETS AND LASHING POTS IN CARGO HOLD – Y20290328301001
- 6.8. CONTAINER PLAN - 7000MPP-070-001
- 6.9. TIMBER LASHING ARRANGEMENT - 7000MPP-070-003-A

7. SAFETY/STATUTORY RESPONSIBILITY

- 7.1. The contractor shall be entirely responsible for the safety of all the personnel employed by him on the work. In this regard, he should adopt all the required safety measure and strictly comply with the safety regulations in force. A copy of CSL's "Safety Rules for Contractors (Revised)" is available with Outsourcing Department for reference.
- 7.2. The Contractor should arrange to suitably insure all his workmen/other personnel in this regard. CSL will not be responsible for any injury or illness to the Contractor's workmen/other personnel during execution of the works due to whatsoever reasons.

TENDER ENQUIRY NOTICE – On-board Installation and Fitment of Cargo Hold Fittings and Lashing Items in in Multi-Purpose Vessels- MPV

- 7.3. In this regard, the Contractor will have to fully indemnify CSL against any claims made by his workmen/other personnel.
- 7.4. The Contractor shall provide and maintain so as to be readily accessible during all working hours, a first aid box with prescribed contents at every place where he employs contract labour for executing the works.



कृते उप महाप्रबंधक / For Deputy General Manager
आउटसोर्सिंग विभाग / Outsourcing Department

ANNEXURE- IV

तकनीकी वाणिज्यिक जांच सूची / TECHNO COMMERCIAL CHECK LIST

(To be submitted by the bidder)

TENDER NO. SB-OSD/MPV/883/2024 Dtd: 15.07.2024

(Bidders may confirm acceptance of the Tender Conditions/deviations if any to be specified)

SL No	Tender Enquiry Requirements	Confirmation from bidder (<u>strike off whichever is not applicable</u>)	Specific comments /Remarks
1	Scope of work as per Technical Specification/Drawings/ General Terms & conditions (Annexure III)	Agreed as per tender /Do not agree	
2	Whether technical bid & two price bids are submitted in separate PDFs?	Yes / No	
3	Schedule of work as specified in technical specification/ price bid of this tender is acceptable	Yes/ No	
4	Submission of Information/Documents with offer	Submitted/Not submitted	
5	Submission of MSME and NSIC registration document with offer	Submitted/Not submitted	
a	Specify the current status of the firm	MSME/MSE/Startup	
6	Offer Validity (date)	90days - Agreed as per tender/Do not agree	
7	Completion period as mentioned in the tender enquiry is acceptable	Yes/ No	
8	Taxes & Duties	Specified/included in Price	
9	Payment terms - confirm		
a	Stage Payment	Agreed as per tender/Do not agree	
b	Any others (Specify details)		

TENDER ENQUIRY NOTICE – On-board Installation and Fitment of Cargo Hold Fittings and Lashing Items in in Multi-Purpose Vessels- MPV

10	Price shall remain firm and fixed and No Escalation in prices after awarding of contract	Agreed as per tender/Do not agree	
11	Security Deposit & Performance Guarantee Clause	Agreed as per tender/Do not agree	
12	The bidder also needs to qualify their welders to meet the requirements as per the work allocation and scope of work.	Agreed as per tender/Do not agree	
13	Termination of contract/risk purchase as per relevant clause in the terms & conditions of tender enquiry is acceptable	Yes / No	
14	Force Majeure	Agreed as per tender/Do not agree	
15	Liquidated damages and cancellation of contract	Agreed as per tender/Do not agree	
16	Arbitration & Jurisdiction clauses	Agreed as per tender/Do not agree	
17	Confirm all other terms and conditions of our enquiry are acceptable.	Confirmed/Not confirmed	
18	Confirm, un-priced price bid (price bid without price) is submitted with Part – I bid	Confirmed/Not confirmed	
19	Mode of submission of tender	Direct / Email	
20	Fully aware about the safety, general rules, regulations, standards, validity of offers and price, entry pass eligibilities.	Yes / No	
21	Is your firm registered under TReDS	Yes/No	
22	Is your firm registered as vendor in CSL	Yes/No	
23	Annual turnover requirement, during last 3 years, ending 31 st March of the previous financial year	Agreed as per tender/Do not agree	
24	Do your firm have valid registration under statutory schemes such as ESI / EPF	Yes/No	
25	Deviations from Tender conditions	No Deviations /Deviations are specified	

हस्ताक्षर / Signature:

ठेकेदार का पता / Address of the Contractor

मुहर / Seal:



ANNEXURE-V

मूल्य बोली प्रारूप / PRICE BID FORMAT

TENDER NO. SB-OSD/MPV/883/2024 Dtd: 15.07.2024

PART-A - DOVETAIL ISO CONTAINER SOCKETS AND LASHING D-RINGS – TOTAL 604 NOS

Sl No	Description of Work	Quantity Per Vessel (A)	Unit Rate (B)	Total amount (INR) (C) = A*B
1	Rate for Package of 10 Nos as per Part A of the scope of work.	60		
2	Rate Per piece as per Part A of the scope of work.	4		
3	SUB TOTAL FOR 1 VESSEL (SUM OF SL No. 1 + 2)			
4	GST% HSN CODE			
5	TOTAL FOR 1 VESSEL (SL No. 3 + 4)			
6	GRAND TOTAL FOR 8 VESSELS (SL No. 5 * 8)			

Grand Total amount (in words)Rupees.....
.....
.....





TENDER ENQUIRY NOTICE – On-board Installation and Fitment of Cargo Hold Fittings and Lashing Items in in Multi-Purpose Vessels- MPV

NOTE:

- A. L1 will be determined based on Sub total amount (Sl. No. 3) excluding GST.
- B. GST as per the prevailing rate will be paid. Bidder should specify HSN also.
- C. L1 declaration will be based on the price bid verification by CSL finance dept as per the calculation specified.
- D. Unit quoted shall be inclusive of labor costs, handling charge, Equipment's, Tools & tackles, consumable charges and any other cost included for the satisfactory completion of all works as specified in Part A of the scope of work.
- E. Quantity mentioned in the price format is only indicative. Downward or upward variation of quantity shall be anticipated. Payment will be made as per the actual quantity of work.

Signature of Contractor/authorized signature
of firm or agency:

Name of contractor or authorised signatory of
firm/agency:

Designation:

Address:

Contact No:



TENDER ENQUIRY NOTICE – On-board Installation and Fitment of Cargo Hold Fittings and Lashing Items in in Multi-Purpose Vessels- MPV

PART-B - FLUSH LASHING POTS – TOTAL 244 NOS

Sl No	Description of Work	Quantity Per Vessel (A)	Unit Rate (B)	Total amount (INR) (C) = A*B
1	Rate for Package of 10 Nos as per Part B of the scope of work.	24		
2	Rate Per piece as per Part B of the scope of work.	4		
3	SUB TOTAL FOR 1 VESSEL (SUM OF SL No. 1 + 2)			
4	GST% HSN CODE			
5	TOTAL FOR 1 VESSEL (SL No. 3 + 4)			
6	GRAND TOTAL FOR 8 VESSELS (SL No. 5 * 8)			

Grand Total amount (in words)Rupees.....
.....

NOTE:

- L1 will be determined based on Sub total amount (Sl. No. 3) excluding GST.
- GST as per the prevailing rate will be paid. Bidder should specify HSN also.
- L1 declaration will be based on the price bid verification by CSL finance dept as per the calculation specified.
- Unit quoted shall be inclusive of labor costs, handling charge, Equipment's, Tools & tackles, consumable charges and any other cost included for the satisfactory completion of all works as specified in Part B of the scope of work.
- Quantity mentioned in the price format is only indicative. Downward or upward variation of quantity shall be anticipated. Payment will be made as per the actual quantity of work.

Signature of Contractor/authorized signature
of firm or agency:

Name of contractor or authorised signatory of
firm/agency:

Designation:

Address:

Contact No:



ANNEXURE-VI

PRE CONTRACT INTEGRITY PACT

COCHIN SHIPYARD LIMITED

OUTSOURCING DEPARTMENT

General

This pre-bid pre-contract Agreement (hereinafter called the Integrity Pact) is made on day of the month of, between, on one hand, the President of India acting through Deputy General Manager, Cochin Shipyard Ltd (CSL) having its registered office at Cochin, Kerala India (hereinafter called the “PRINCIPAL”, which expression shall mean and include, unless the context otherwise requires, his successors in office and assigns) of the First part and M/s.....represented by Shri..... Chief Executive Officer (hereinafter called the “BIDDER/Seller” which expression shall mean and include, unless the context otherwise requires, his successors and permitted assigns) of the second part.

WHEREAS the PRINCIPAL proposes to procure and the BIDDER/Seller is

Willing to offer/has offered the stores and

WHEREAS the BIDDER is a private company / public company / Government undertaking / Partnership / registered export agency, constituted in accordance with the relevant law in the matter And the PRINCIPAL is a Government of India PSU performing its functions on behalf of the President of India.

NOW, THEREFORE,

To avoid all forms of corruption by following a system that is fair, transparent and free from any Influence/prejudiced dealings prior to, during and subsequent to the currency of the contract to be

Entered into with a view to:-



TENDER ENQUIRY NOTICE – On-board Installation and Fitment of Cargo Hold Fittings and Lashing Items in in Multi-Purpose Vessels- MPV

Enabling the PRINCIPAL to obtain the desired said stores/equipment/item at a competition price in Conformity with the defined specifications by avoiding the high cost and the distortionary impact of

Corruption on public procurement, and Enabling BIDDERS to abstain from bribing or indulging in any corrupt practice in order to secure the Contract by providing assurance to them that their competitors will also abstain from bribing and Other corrupt practices and the PRINCIPAL will commit to prevent corruption, in any form, by its Officials by following transparent procedures.

The parties hereto hereby agree to enter into this Integrity Pact and agree as follows:-

1. COMMITMENTS OF THE PRINCIPAL

- 1.1. The PRINCIPAL undertakes that no official of the PRINCIPAL, connected directly or indirectly with the contract, will demand, take a promise for or accept, directly or through intermediaries, any bribe, consideration, gift, reward, favour or any material or immaterial benefit or any other advantage from the BIDDER, either for themselves or for any person, organization or third party related to the contract in exchange for an advantage in the bidding process, bid evaluation, contracting on implementation process related to the contract.
- 1.2. The PRINCIPAL will, during the pre-contract stage, treat all BIDDERS alike and will provide to all BIDDERS the same information and will not provide any such information to any particular BIDDER which could afford an advantage to that particular BIDDER in comparison to other BIDDERS.
- 1.3. The officials of the PRINCIPAL will report to the appropriate Government office any attempted or completed breaches of the above commitments as well as any substantial suspicion of such a breach.

In case any such preceding misconduct on the part of such official(s) is reported by the BIDDER to the PRINCIPAL with full and verifiable facts and the same is prima facie found to be correct by the PRINCIPAL, necessary disciplinary proceedings, or any other action as deemed fit, including criminal proceedings may be initiated by the PRINCIPAL and such a person shall be debarred from further dealings related to the contract process. In such a case while an enquiry is being conducted by the PRINCIPAL the proceedings under the contract would not be stalled.

2. COMMITMENTS OF BIDDERS

The BIDDER commits itself to take all measures necessary to prevent corrupt practices, unfair means and illegal activities during any stage of its bid or during any pre-contract or post-contract stage in order to secure the contract or in furtherance to secure it and in particular commit itself to the following:-

- 2.1. The BIDDER will not offer, directly or through intermediaries, any bribe, gift, consideration, reward, favour, any material or immaterial benefit or other advantage, commission, fees, brokerage or inducement to any official of the PRINCIPAL, connected directly or indirectly with the bidding process, or to any person, organization or third party related to the contract in exchange for any advantage in the bidding, evaluation, contracting and implementation of the contract.
- 2.2. The BIDDER further undertakes that it has not given, offered or promised to give, directly or indirectly any bribe, gift, consideration, reward, favour, any material or immaterial benefit or other advantage, commission, fees, brokerage or inducement to any official of the PRINCIPAL or otherwise in procuring the Contract or forbearing to do or having done any act in relation to the obtaining or execution of the contract of any other contract with the government for showing or forbearing to show favour or disfavor to any person in relation to the contract of any other contract with the Government.
- 2.3. BIDDERS of foreign origin shall disclose the name and address of their Indian agents and representatives, if any and Indian BIDDERS shall disclose their foreign principals or associates, if any.
- 2.4. BIDDERS shall disclose the payments to be made by them to their Indian agents/brokers or any other intermediary, in connection with this bid/contract and the payments have to be in Indian Rupees only.
- 2.5. The BIDDER further confirms and declares to the PRINCIPAL that the BIDDER is the original manufacturer/ integrator/authorized agent of the stores/equipment/items and has not engaged any individual or firm or company whether Indian or foreign to intercede, facilitate or in any way to recommend to the PRINCIPAL or any of its functionaries, whether officially or unofficially to the award of the contract to the BIDDER, nor has any amount been paid, promised or intended to be paid to any such individual, firm or company in respect of any such intercession, facilitation or recommendation.
- 2.6. The BIDDER, either while presenting the bid or during pre-contract negotiations or before signing the contract, shall disclose any payments he has made, is committed to or intends

TENDER ENQUIRY NOTICE – On-board Installation and Fitment of Cargo Hold Fittings and Lashing Items in in Multi-Purpose Vessels- MPV

to make to officials of the PRINCIPAL or their family members, agents, brokers or any other intermediaries in connection with the contract and the details of services agreed upon for such payments.

- 2.7. The BIDDER will not collude with other parties interested in the contract to impair the transparency, fairness and progress of the bidding process, bid evaluation, contracting and implementation of the contract.
- 2.8. The BIDDER will not accept any advantage in exchange for any corrupt practice, unfair means and illegal activities.
- 2.9. The BIDDER shall not use improperly, for purposes of competition or personal gain, pass on to others, any information provided by the PRINCIPAL as part of the business relationship, regarding plans, technical proposals and business details, including information contained in any electronic data carrier. The BIDDER also undertakes to exercise due and adequate care lest any such information is divulged.
- 2.10. The BIDDER commits to refrain from giving any complaint directly or through any other manner without supporting it with full and verifiable facts.
- 2.11. The BIDDER shall not instigate or cause to instigate any third person to commit any of the actions mentioned above.
- 2.12. If the BIDDER or any employee of the BIDDER or any person acting on behalf of the BIDDER, either directly or indirectly, is a relative of any of the officers of the PRINCIPAL, or alternatively, if any relative of an officer of the PRINCIPAL has financial interest/stake in the BIDDER's firm, the same shall be disclosed by the BIDDER at the time of filing of tender. The term 'relative' for this purpose would be as defined in section 6 of the Companies Act 1956.
- 2.13. The BIDDER shall not lend to or borrow any money from or enter into any monetary dealings or transactions, directly or indirectly, with any employee or the PRINCIPAL.

3. PREVIOUS TRANSGRESSION

- 3.1. The BIDDER declares that no previous transgression occurred in the last three years immediately before signing of this Integrity Pact, with any other company in any country in respect of any corrupt practices envisaged hereunder or with any Public Sector Enterprise in India or any Government Department in India that could justify; BIDDER's exclusion from the tender process.

TENDER ENQUIRY NOTICE – On-board Installation and Fitment of Cargo Hold Fittings and Lashing Items in in Multi-Purpose Vessels- MPV

3.2. The BIDDER agrees that if it makes incorrect statement on this subject, BIDDER can be disqualified from the tender process or the contract, if already awarded, can be terminated for such reason.

4. EARNEST MONEY (SECURITY DEPOSIT)

4.1. While submitting commercial bid, the BIDDER shall deposit an amount NIL (to be specified in RFP) as Earnest Money as applicable/Security Deposit, with the PRINCIPAL through any of the following instruments:

- (i) Bank Draft of Pay Order in favor of CSL.
- (ii) A confirmed guarantee by an Indian Nationalized Bank, promising payment of the guaranteed sum to the PRINCIPAL on demand within three working days without any demur whatsoever and without seeking any reasons whatsoever. The demand for payment by the PRINCIPAL shall be treated as conclusive proof of payment.
- (iii) Any other mode or through any other instrument (to be specified in the RFP).

4.2. The Earnest Money if applicable/Security Deposit shall be valid upto the complete conclusion of the contractual obligations to the complete satisfaction of both the BIDDER and the PRINCIPAL, including warranty period.

4.3. In case of the successful BIDDER a clause would also be incorporated in the Article pertaining to Performance Bond in the Purchase Contract that the provisions of sanctions for Violation shall be applicable for forfeiture of Performance Bond in case of a decision by the PRINCIPAL to forfeit the same without assigning any reason for imposing sanction for violation of this Pact.

4.4. No interest shall be payable by the PRINCIPAL to the BIDDER on Earnest Money/Security Deposit for the period of its currency.

5. SANCTIONS FOR VIOLATIONS

5.1. Any breach of the aforesaid provisions by the BIDDER or any one employed by it or acting on its behalf (whether with or without the knowledge of the BIDDER) shall entitle the PRINCIPAL to take all or any one of the following actions, wherever required: -

- (i) To immediately call off the pre contract negotiations without assigning any reason or giving any; compensation to the BIDDER. However, the proceedings with the other BIDDER(s) would continue.
- (ii) The Earnest Money Deposit (in pre-contract stage) and/or Security Deposit/Performance Bond (after the contract is signed) shall stand forfeited either fully or partially, as decided by the PRINCIPAL and the PRINCIPAL shall not be required to assign any reason therefore.

TENDER ENQUIRY NOTICE – On-board Installation and Fitment of Cargo Hold Fittings and Lashing Items in in Multi-Purpose Vessels- MPV

(iii) To immediately cancel the contract, if already signed, without giving any compensation to the BIDDER.

(iv) To recover all sums already paid by the PRINCIPAL, and in the case of an Indian BIDDER with interest thereon at 2% above the prevailing Prime Lending Rate of State Bank of India, while in case of a BIDDER from a country other than India with interest thereon at 2% above the LIBOR (London Inter Bank Offer Rate). If any outstanding payment is due to the BIDDER from the PRINCIPAL in connection with any other contract for any other stores, such outstanding payment could also be utilized to recover the aforesaid sum and interest.

(v) To en cash the advance bank guarantee and performance bond/warranty bond, if furnished by the BIDDER, in order to recover the payments, already made by the PRINCIPAL, along with interest.

(vi) To cancel all or any other contracts with the BIDDER. The BIDDER shall be liable to pay compensation for any loss or damage to the PRINCIPAL resulting from such cancellation/recession and the PRINCIPAL shall be entitled to deduct the amount so payable from the money(s) due to the BIDDER.

(vii) To debar the BIDDER from participating in the future bidding processes of CSL for a minimum period as deemed appropriate, which any be further extended at the discretion of the PRINCIPAL.

(viii) To recover all sums paid in violation of this Pact by BIDDER(s) to any middle man or agent or broker with a view to securing the contract.

(ix) In cases where irrevocable Letters of Credit have been received in respect of any contract signed by the PRINCIPAL with the BIDDER, the same shall not be opened.

(x) Forfeiture of Performance Bond in case of a decision by the PRINCIPAL to forfeit the same without assigning any reason for imposing sanction for violation of this pact.

5.2. The PRINCIPAL will be entitled to take all or any of the actions mentioned at para 6.1(i) to (x) of this pact also on the Commission by the BIDDER or any one employed by it or acting on its behalf (whether with or without the knowledge of the BIDDER), of an offence as defined in chapter IX of the Indian Penal code, 1860 or Prevention of Corruption Act, 1988 or any other statute enacted for prevention of corruption.

5.3. The decision of the PRINCIPAL to the effect that a breach of the provisions of this pact has been committed by the BIDDER shall be binding on the BIDDER. However, the BIDDER can approach the Independent Monitor(s) appointed for the purposes this Pact.

6. FALL CLAUSE

6.1. The BIDDER undertakes that it has not supplied/is not supplying similar product/systems/items or subsystems at a price lower than that offered in the present bid in respect of any other Ministry/Department of the Government of India or PSU and if it is found at any stage that similar product/systems or sub systems/items was supplied by the BIDDER to any other Ministry/Department of the Government of India or PSU at a lower price, then that very price, with due allowance for elapsed time, will be applicable to the present case and the difference in the cost would be refunded by the BIDDER to the PRINCIPAL, if the contract has already been concluded.

7. INDEPENDENT MONITORS

7.1. The PRINCIPAL has appointed Independent Monitors (hereinafter referred to as Monitors) for this Pact in consultation with the Central Vigilance Commission.

(i) Shri. Jagadip Narayan Singh, IAS (Retd.),
C-54, Bharatendu Harischandra Marg,
Anand Vihar, Delhi – 110092.
Mobile: 9978405930
Email: jagadipsingh@yahoo.com

7.2. The task of the Monitors shall be to review independently and objectively, whether and to what extent the parties comply with the obligations under this Pact.

7.3. The Monitors shall not be subject to instructions by the representatives of the parties and perform their functions neutrally and independently.

7.4. Both the parties accept that the Monitors have the right to access all the documents relating to the project/procurement, including minutes of meetings.

7.5. As soon as the Monitor notices, or has reason to believe, a violation of this pact, he will so inform the Authority designated by the PRINCIPAL.

7.6. The PRINCIPAL accepts that the Monitor has the right to access without restriction to all Project documentation of the BUYER including that provided by the BIDDER. The BIDDER will also grant the Monitor, upon his request and demonstration of a valid interest, unlimited access to his project documentation. The same is applicable to Subcontractors. The Monitor shall be under contractual obligation to treat the information and documents of the BIDDER/Subcontractor(s) with confidentiality.

TENDER ENQUIRY NOTICE – On-board Installation and Fitment of Cargo Hold Fittings and Lashing Items in in Multi-Purpose Vessels- MPV

7.7. The PRINCIPAL will provide to the Monitor sufficient information about all meetings among the parties related to the Project provided such meetings could have an impact on the contractual relations between the parties. The parties will offer to the Monitor the option to participate in such meetings.

7.8. The Monitor will submit a written report to the designated Authority of PRINCIPAL/Secretary in the Department/ within 8 to 10 weeks from the date of reference or intimation to him by the PRINCIPAL /BIDDER and, should the occasion arise, submit proposals for correcting problematic situations.

8. FACILITATION OF INVESTIGATION

In case of any allegation of violation of any provisions of this pact or payment of commission, the PRINCIPAL or its agencies shall be entitled to examine all the documents including the Books of Accounts of the BIDDER. The BIDDER shall provide necessary information and documents in English and shall extend all possible help of the purpose of such examination/inspection.

9. LAW AND PLACE OF JURISDICTION

This Pact is subject to Indian Law. The place of performance and jurisdiction is the seat of the PRINCIPAL.

10. OTHER LEGAL ACTIONS

The actions stipulated in this Integrity Pact are without prejudice to any other legal action that may follow in accordance with the provisions of the extent law in force relating to any civil or criminal proceedings.

11. VALIDITY

11.1. The validity of this Integrity Pact shall be from date of its signing and extend upto 5 years

or the complete execution of the contract to the satisfaction of both the PRINCIPAL and the BIDDER/Seller, including warranty period, whichever is later. In case BIDDER is unsuccessful, this Integrity Pact shall expire after six months from the date of the signing of the contract.



TENDER ENQUIRY NOTICE – On-board Installation and Fitment of Cargo Hold Fittings and Lashing Items in in Multi-Purpose Vessels- MPV

11.2. Should one or several provisions of this Pact turn out to be invalid; the remainder of this pact shall remain valid. In this case, the parties will strive to come to an agreement to their original intentions.

The parties hereby sign this Integrity Pact at.....on.....

**For & on behalf of PRINCIPAL
Cochin Shipyard Limited
(Office Seal)**

**For & on behalf of BIDDER
(Office Seal)**

Witness

1.....

2.....

Witness

1.....

2.....

* Provisions of these clauses would need to be amended/deleted in line with the policy of the BUYER in regard to involvement of Indian agents of foreign suppliers.





ANNEXURE-VII

DECLARATION

I hereby declare that the details furnished in this tender proposal are true and correct to the best of my knowledge and belief. In case any of the information is found to be false or untrue or misleading or misrepresenting, I am aware that I will be held liable for it and CSL is free to take any legal / commercial action not limited to barring / blacklisting.

We hereby declare that we are not under a declaration of ineligibility / blacklisting /debaring/ tender holiday from doing business issued by Govt. of India / State govt. / Public Sector Undertakings etc.

Yours faithfully,

(Signature & Seal of Authorised Signatory)





TENDER ENQUIRY NOTICE – On-board Installation and Fitment of Cargo Hold Fittings and Lashing Items in in Multi-Purpose Vessels- MPV

APPENDIX- A

COMPLIANCE MATRIX

<u>Clause No.</u>	<u>Compliance/ Deviation</u>

Notes:

1. If offer is not fully conforming to the requirements given in any clause of this specification, the deviation shall be stated in detail against the particular clause in the Compliance matrix.



APPENDIX - B

FORMAT FOR FINANCIAL CAPABILITY

Sl. No.	Last three Financial Year	Annual Turnover	Profit after Tax (PAT)	Net worth as at the end of the financial year
1	Year 2020-21			
2	Year 2021-22			
3	Year 2022-23			

To be signed by the Authorized Signatory of the Applicant with Name, Designation, seal and date.

Certificate from Chartered Accountant:

This is to certify that _____ (name of the Applicant) has received the payments shown above against the respective years and that the net worth is as computed.

Name of the Authorized Signatory representing Auditing firm:

Designation:

Name of firm (Chartered Accountant):

Signature of the Authorized Signatory:

Seal of Audit firm

23	22	21	19	18	17	15	14	13	11	10	09	07	06	05	03	02	01	20' BAY	DECK
																		40' BAY	DECK

23	22	21	19	18	17	15	14	13	11	10	09	07	06	05	03	02	01	20' BAY	HOLD
																		40' BAY	HOLD

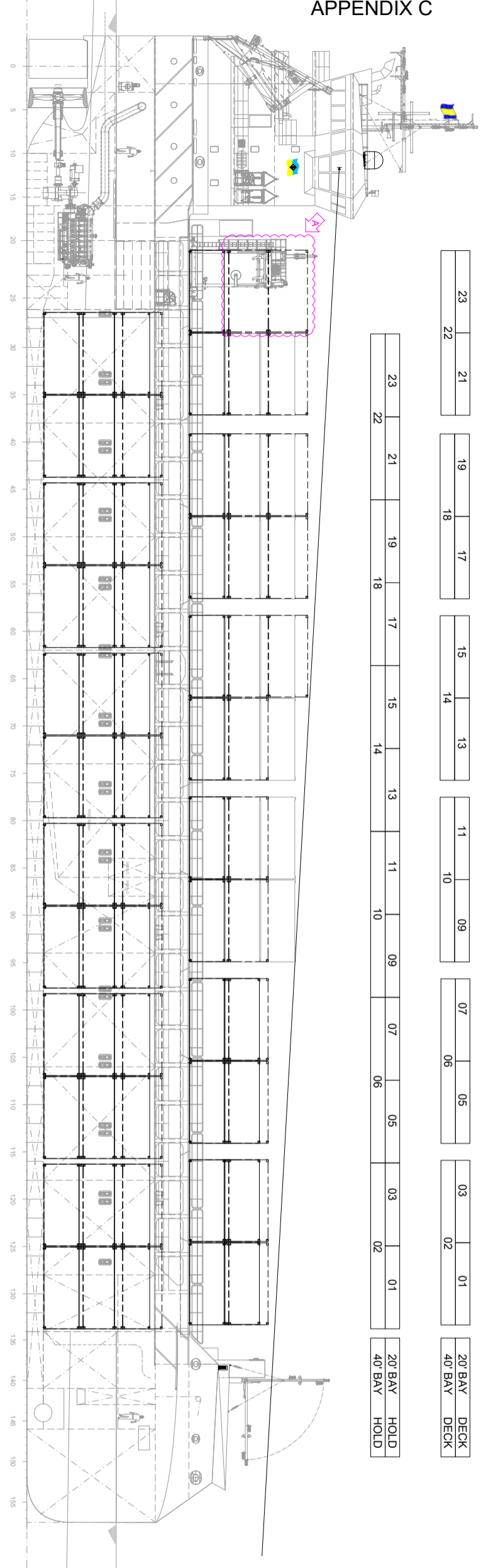

LONGITUDINAL VIEW
20' / 40' FEET CONTAINERS

ROW	04	02	00	01	03
-----	----	----	----	----	----

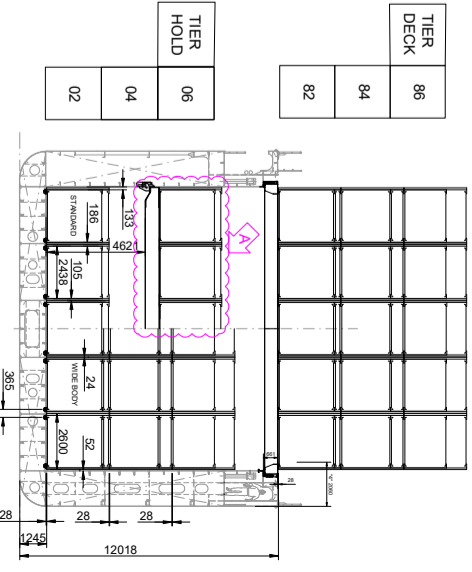

TRANSVERSERS VIEW
STANDARD, WIDE BODY AND HIGH-CUBE CONTAINERS

TOTAL CONTAINER POSITIONS		HEIGHT	LENGTH
TEU	DECK	86"	96"
FEU	HOLD	160	145
	DECK	168	168
	HOLD	70	60
	HOLD	75	75

General particulars

Length over all 109,95 m
Length between perpendiculars 107,70 m
Breadth moulded 16,50 m
Depth moulded 9,50 m
Draft summer 6,60 m

STACK LOAD:
Tank Top 75 UTEU (point load)
90 UFEU (point load)
Hatch Covers 28U/TEU (point load)
52U/TEU (point load)

NOTES:

1. Securing in hold by means of twistlocks only.
2. Securing on deck by means of twistlocks and lashings.
3. All stacks suitable for 2600 mm wide body containers.
4. Dangerous Goods class 1 (except 1.4) shall not to be positioned closer to the ship's sides than 2,06 m.
5. Lashing as per Container lashing manual.
6. Container on tween decks to be stowed and secured as project cargo.
7. Gantry crane can be taken ashore for possibility of full stack of containers.

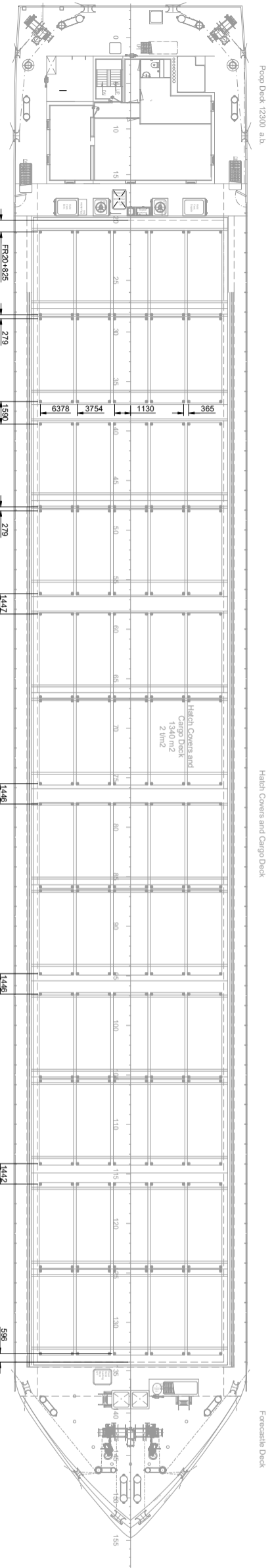

TOP VIEW CONTAINERS ON TOP OF HATCH COVERS
20' / 40' FEET CONTAINERS

ROW	03	01	00	02	04
-----	----	----	----	----	----

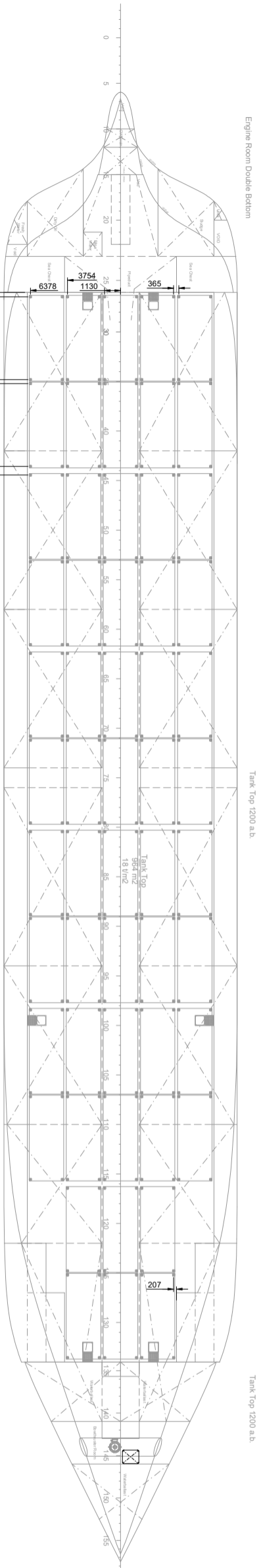

TOP VIEW CONTAINERS ON TANK TOP
20' / 40' FEET CONTAINERS

ROW	04	02	00	01	03
-----	----	----	----	----	----

COORN SHIPYARD LIMITED
K.O. Weg 104A, 4306-AB, Nieuw
www.hs-schiffahrt.de

HS Schiffahrt
Maritime

GROOT / SHIP DESIGN
Competence Shipping

Contractor: SA
The Netherlands

Scale: 1:125
Date: 18/08/2022

Client: HS Schiffahrt

Drawing No.: 7000MPP-070-001

Sheet: 1/1

Rev: A

LONGITUDINAL VIEW

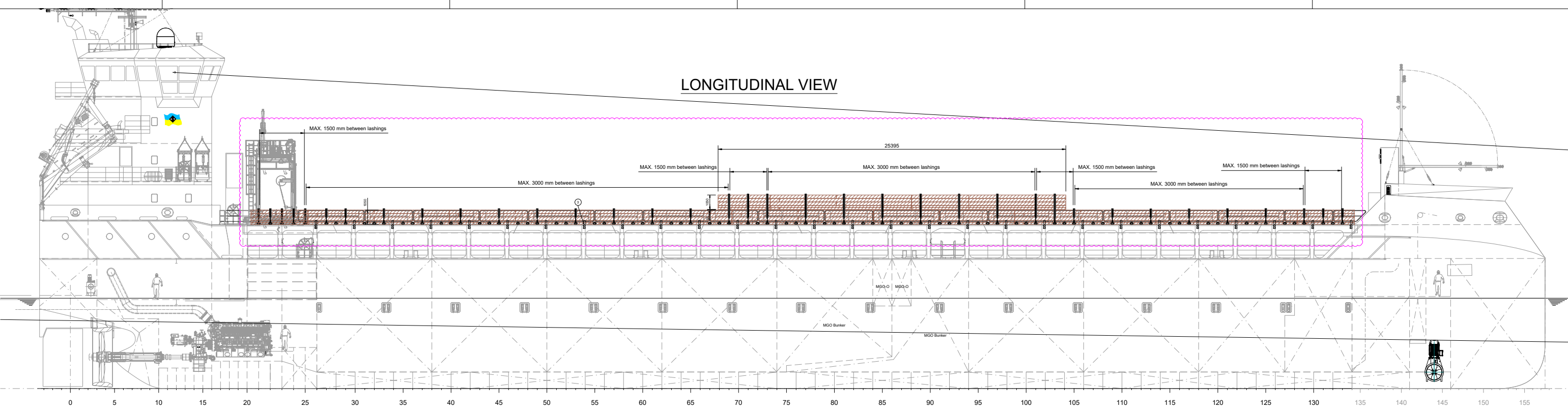

TOP VIEW

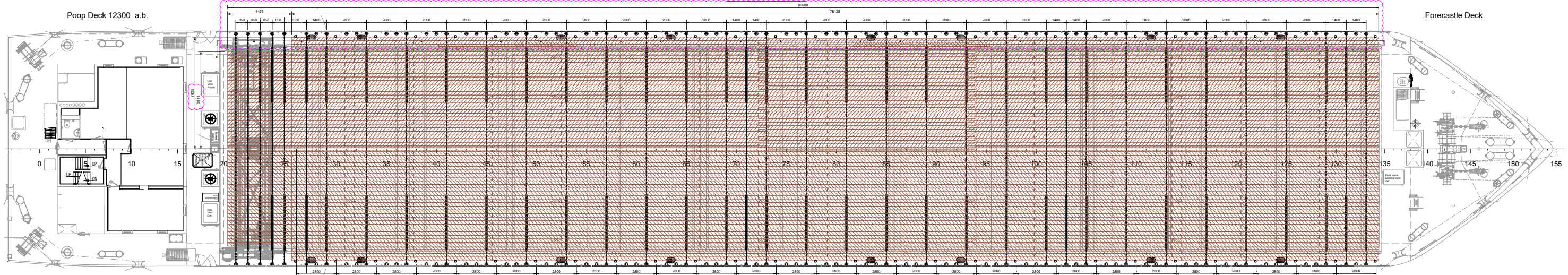

TIMBER TRANSVERSE VIEW

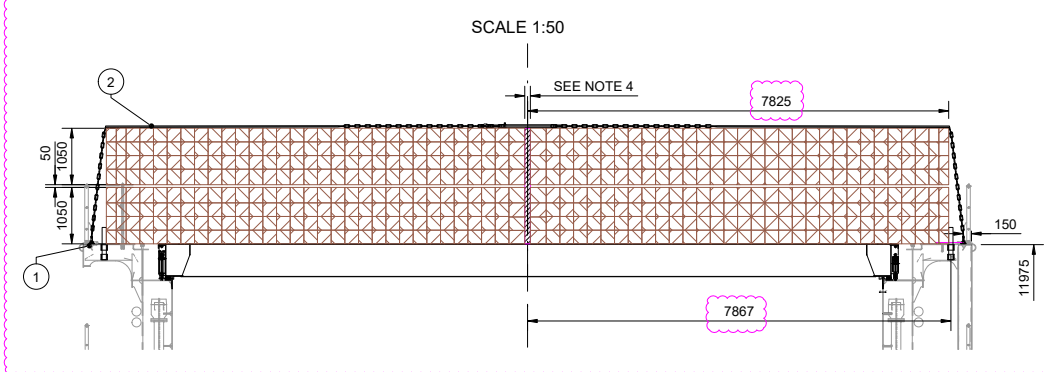

Detail 1 scale 1:5

Stoppers from wood 12x8 cm, MSL=30 kN

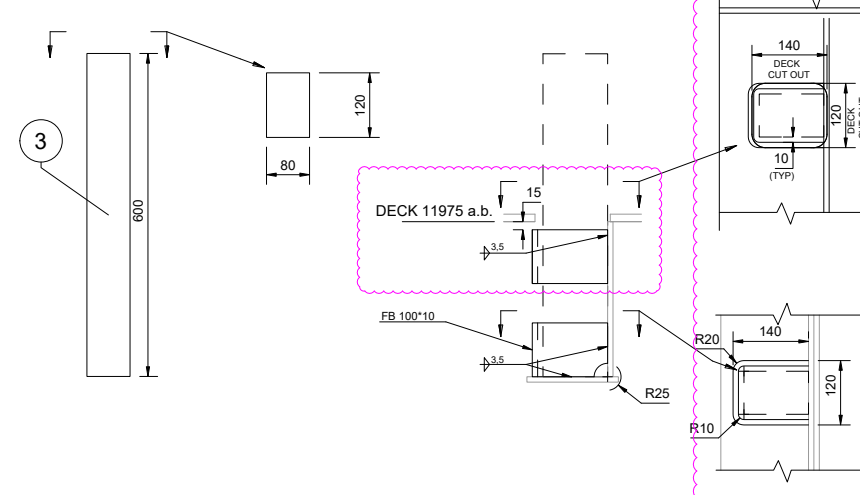

Remarks:

- This is an example. Specific lashing calculations to be made for each timber load case.
- Timber lashing as per timber lashing manual

NOTES:

- Timber lashing arrangement made according to TDC CODE 2011
- All lashing and components used for securing should possess a breaking strength of not less than 133 kN
- The load to be produced by tightening device or system should not be less then:
 - 27kN in horizontal part
 - 17kN in vertical part
- MSL (maximum secure load) of frames for different widths

Dimensions of battens mm	MSL in kN of double H-frames with different widths			
	0.5 m	1.0 m	1.5 m	2.0 m
50x50	75	53	30	17
50x75	113	79	46	26
50x100	151	106	61	34
50x150	226	159	91	51
75x75	186	153	119	85
75x100	248	203	159	114
75x150		305	238	171
100x100			317	227
100x100			301	256

Pos	Number	Type	Dim.	Material	Comp. no.
3	56	Stoppers			
2	37	Top-over lashing system			
1	172	Lashing eyes			

COCHIN SHIPYARD LIMITED
P.O. Box 1653, COCHIN-482015, INDIA

HS Schiffahrt
HARBOR & TANKS
Compliance shipping

GROUPT SHIP DESIGN

Scale: 1:100 GSD No.: P22003-070-003
Drawn: BGO Date: 16/09/2022
Checked: WN Date: 16/09/2022
Client: HS Schiffahrt

Title: Timber Lashing Plan

Drawing No.: 7000MPP-070-003 Sh.: 1/2 Rev.: A

LONGITUDINAL VIEW

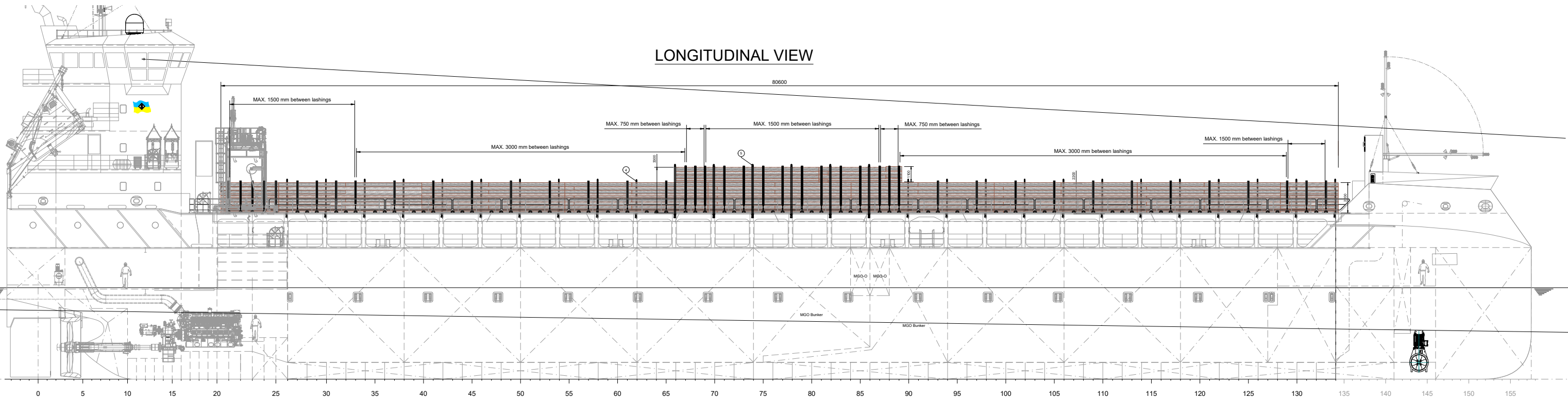

TOP VIEW

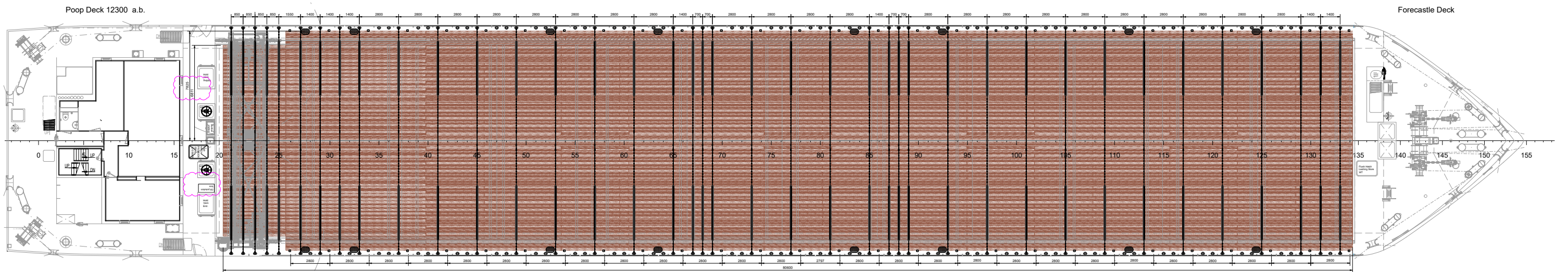

LOGS TRANSVERS VIEW

SCALE 1:50

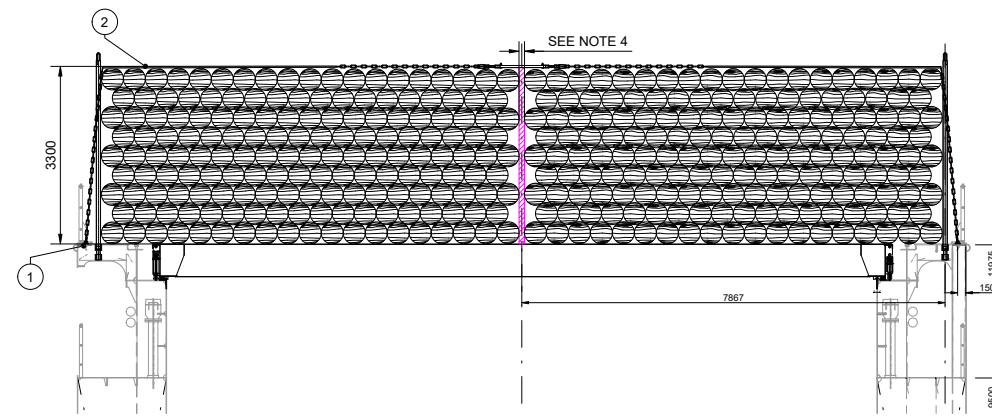

Detail 2
scale 1:5
Stoppers from steel/wood 12x8 cm, MSL=30 kN

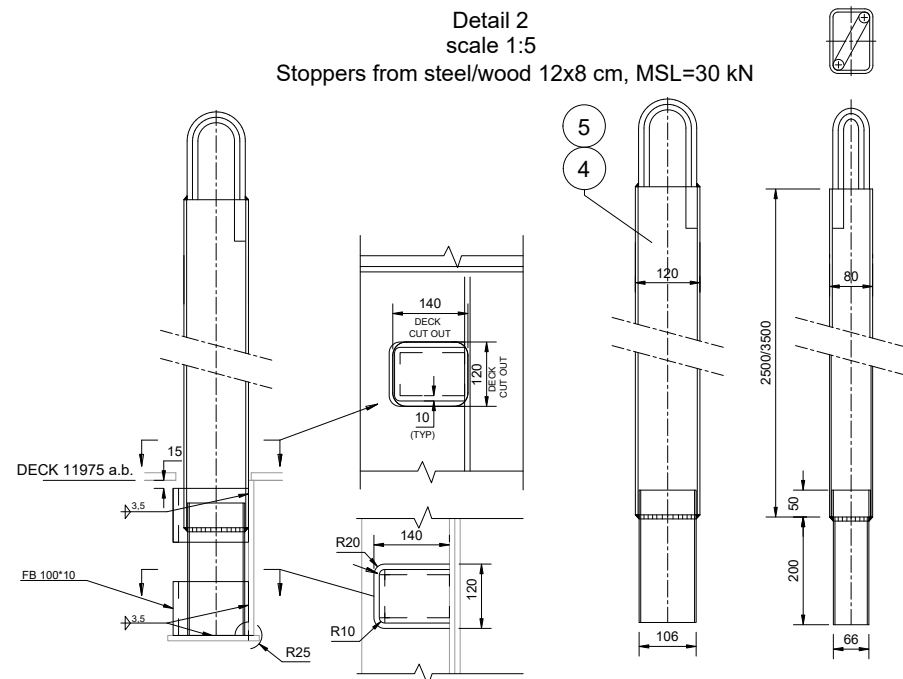

Pos.	Number	Type	Dim.	Material	Comp. no.
5	12	Stopper h=3500m			
4	44	Stopper h=2500m			
3	N/A	Stopper			
2	43	Top-over lashing system			
1	172	Lashing eyes			

www.hs-schiffahrt.de

HS Schiffahrt
MARSHALL ISLANDS
Competence shipping

GROOT SHIP DESIGN

COCHIN SHIPYARD LIMITED P.O. Box 1653, COCHIN-682015, INDIA		Scale: 1:100		GSD No.: P22003-070-003	
Drawn: BGO		Date: 16/09/2022		Title: Timber Lashing Plan	
Checked: WN		Date: 16/09/2022		Drawing No.: 7000MPP-070-003	
Client: HS Schiffahrt		Sh.: 2/2		Rev.: A	

Lorentzpark 3A
9353 VJ Leek
The Netherlands

AD-COPYRIGHTS RESERVED

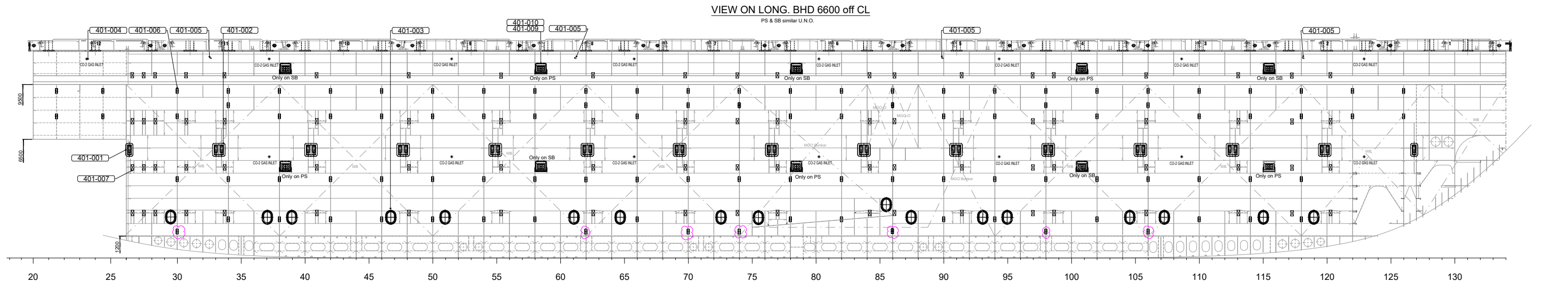
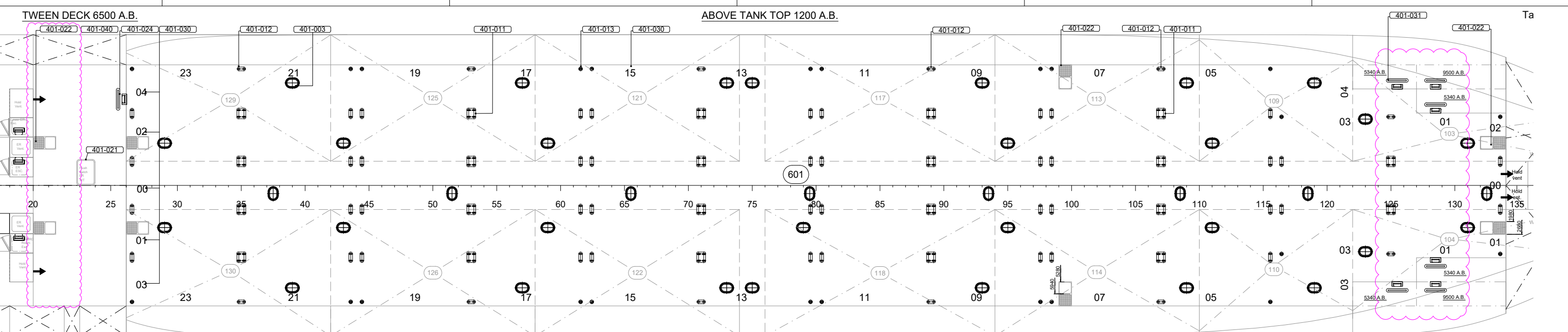

POS.	Qty	Description	Remarks
401-001	8	SUPPORT TWEENDECK PANEL	SINGLE
401-002	26	SUPPORT TWEENDECK PANEL	DOUBLE
401-003	75	OVAL MANHOLE FLUSH TYP	see. 7000MPP-132-001
401-004	30	CO2 NOZZLE HOLDER (TEXT ADDED)	MX-05-20 (MINIMAX)
401-005	8	GAS SAMPLING POINT	also for temp. monitoring
401-006	244	FLUSH LASHING SOCKET	SWL 245kN
401-007	168	SIDE PINS FOR REM. GRAIN BULKHEAD	
401-008	4	WELLGLASS LIGHT FIXTURE	
401-009	12	HOLD LIGHTING	
401-010	12	HOLD LIGHTING PROTECTION GRID	
401-011	22	FLUSH TWIST LOCK POCKETS (FS-4)	
401-012	56	FLUSH TWIST LOCK POCKETS (FS-2)	
401-013	24	FLUSH TWIST LOCK POCKETS (FS-1)	
401-014	2	LEVEL ALARM/WATER INGRESS ALARM BILGE WELL	Intrinsically safe
401-015	2	AIR FAN MOUNTING PLATE	see. 7000MPP-130-001
401-016	2	AIR FAN	
401-017	1	OVERPRESSURE TUBE FAN	
401-018	4	6 mm ALU COVER PLATE SCREWED BY BOLTS	YARD STD.
401-019	2	STEPS-SQUARE BAR	
401-020	2	HOLLOW RECT. TUBES 150x50x3	
401-021	1	FLUSH HATCH ER (WT)	see. 7000MPP-130-001
401-022	8	BILGE WELL WITH FILTER	
401-023	2	WATER INGRESS ALARM ON THE BHD.	intrinsically safe
401-024	1	WT DOOR CARGO HOLD ENTRANCE AFT SHIP	see. 7000MPP-133-001
401-025	2	POWDER EXTINGUISHER 6KG	
401-026	24	BOUNDARIES OF FUEL OIL TANKS	STRIP, PAINTED RED
401-027	12	BOUNDARIES OF FUEL OIL TANKS	L-SHAPE, PAINTED RED
401-028	4	"NO WELDING HERE" SIGN	PAINTED RED
401-029	4	"NO SMOKING" SIGN	MARKED/PAINTED RED BHD FR20/26/134 (MARKED/PAINTED)
401-030	34	CONTAINER BAY NUMBER	
401-031	7	HANDGRIP IN RECESS	
401-032	7	LADDER IN RECESS	see. 7000MPP-140-001
401-033	2	LADDER CARGO HOLD VENT AFT SHIP (OUTSIDE)	see. 7000MPP-140-001
401-034	1	LADDER CARGO HOLD VENT AFTSHIP (INSIDE)	see. 7000MPP-140-001
401-035	2	LADDER CARGO HOLD VENT FORESHIP (INSIDE)	see. 7000MPP-140-001
401-036	2	LADDER CARGO HOLD VENT AFT SHIP (OUTSIDE)	see. 7000MPP-140-001
401-037	2	CARGO HOLD VENT INLET HATCH WITH MISTELIMINATOR	A=2.5m² W 1090xH 12500mm
401-038	4	CARGO HOLD VENT OUTLET HATCH WITH MISTELIMINATOR	A=2.3m² W 1090xH 1070mm
401-039	5	HANDGRIP	
401-040	2	FOOTSTEP	
401-041	1	WT HATCH CARGO HOLD ENTRANCE FORESHIP	see. 7000MPP-130-001
401-042	2	MANHOLE FOR AIR FAN MOUNTING	see. 7000MPP-132-001

VIEW ON THE SB LONGITUDINAL BULKHEAD SCALE 1:50

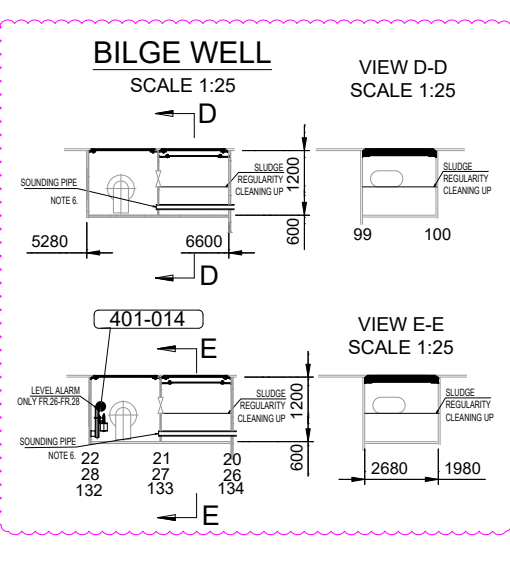
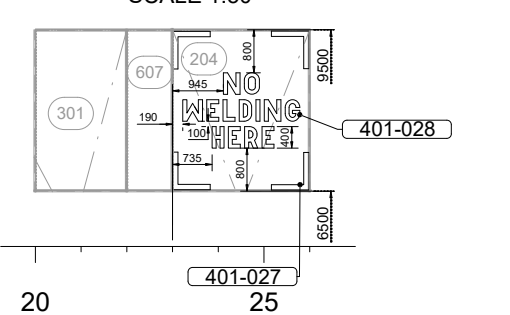

VIEW ON THE LONGITUDINAL BULKHEAD SCALE 1:50

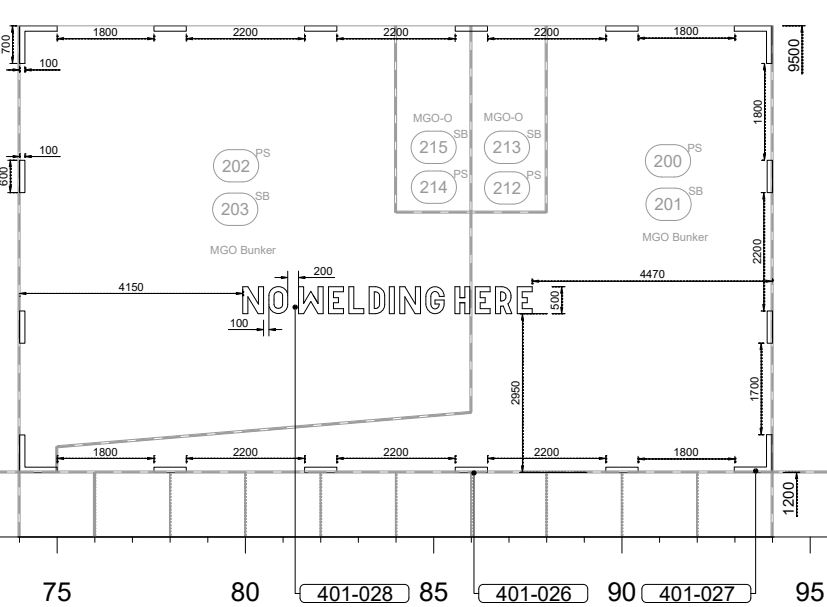

Notes:

- Welding allowed everywhere on tanktop and tween deck 6500aB above ER
- Welding allowed everywhere on longitudinal and transverse bulkheads except in areas of fuel or lubrication oil tanks, which are marked with "NO WELDING HERE"
- CO2 gas inlets also used for smoke sampling
- Load on the tank top of cargo hold 18t/m2
- Marking "No Smoking" and "No welding" is painted only, without welding bead.
- For sounding in bilge wells see 7000MPP-350-001
- For final information regarding ventilation please see MPP7-H01-001 and MPP7-H02-001.

VIEW ON LONG. BHD 5280 off CL

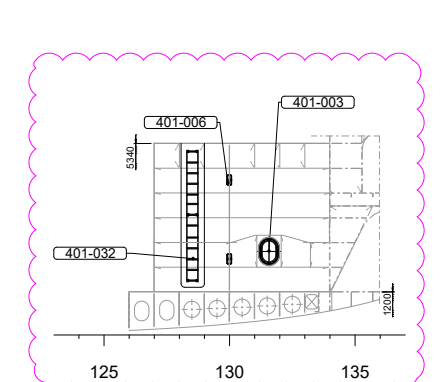

VIEW ON LONG. BHD 5280 off CL

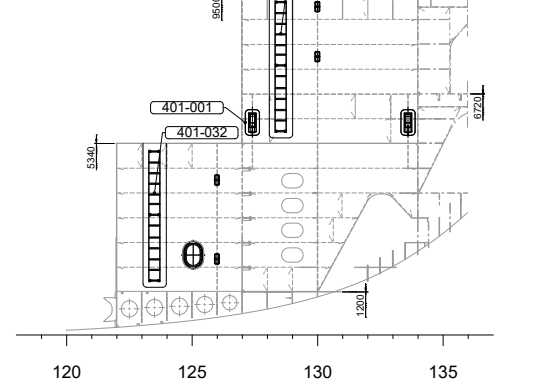

- REFERENCE DRAWINGS:
- 7000MPP-000-002 GENERAL ARRANGEMENT
 - 7000MPP-079-001 TANK ARRANGEMENT
 - 7000MPP-070-005 HAZARDOUS ZONE PLAN
 - 7000MPP-100-402 COAMING ARRANGEMENT
 - 7000MPP-100-004 CONSTRUCTION PLAN - MIDSHIP - CARGO AREA
 - 7000MPP-130-001 ESCAPE/ ACCESS/ SMALL HATCHES PLAN
 - 7000MPP-131-001 HATCHCOVER PLAN
 - 7000MPP-131-002 TWEENDECK PANEL / GRAINBULKHEAD PLAN
 - 7000MPP-132-001 MANHOLE PLAN
 - 7000MPP-133-001 DOOR PLAN
 - 7000MPP-140-001 LADDER PLAN
 - 7000MPP-570-003 FIRE CONTROL AND SAFETY PLAN
 - 7000MPP-720-001 FIRE INTEGRITY PLAN
 - 7000MPP-350-001 SOUNDING, FILLIND, DEARATION PLAN
 - MPP7-H01-001 VENTILATION PLAN
 - MPP7-H02-001 VENTILATION SCHEME

COCHIN SHIPYARD LIMITED
P.O. Box 1653, COCHIN-682015, INDIA

www.hs-schiffahrt.de
www.grootshipdesign.nl

Scale: 1:75 GSD No.: P22003
Drawn: MR Date: 09-06-2022
Checked: WN Date: 10-06-2022

Client: **CARGO HOLD ARRANGEMENT**

Drawing No.: 7000MPP-100-401 Sh: 1/2 Rev: B

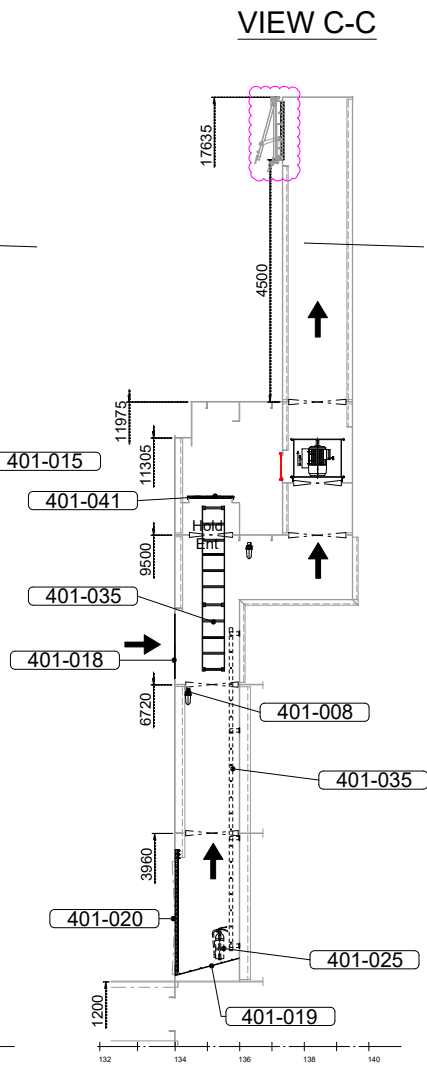
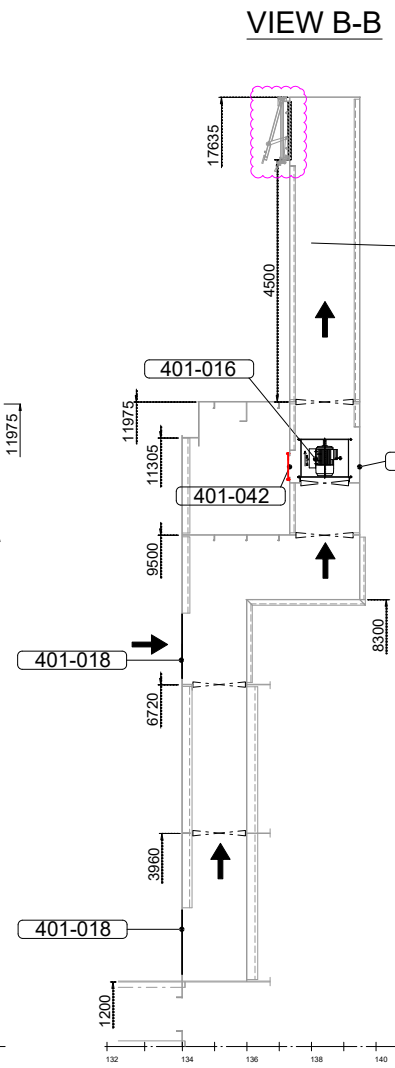
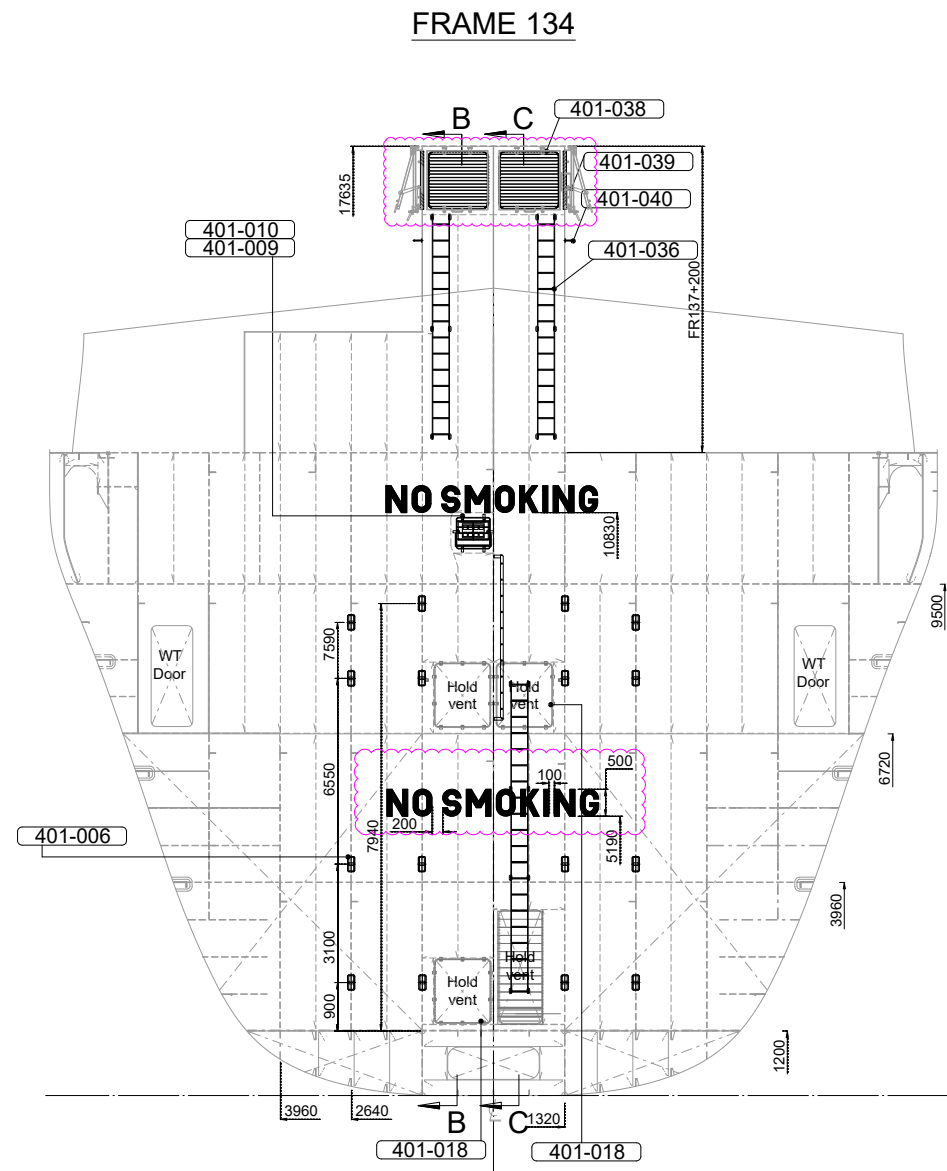
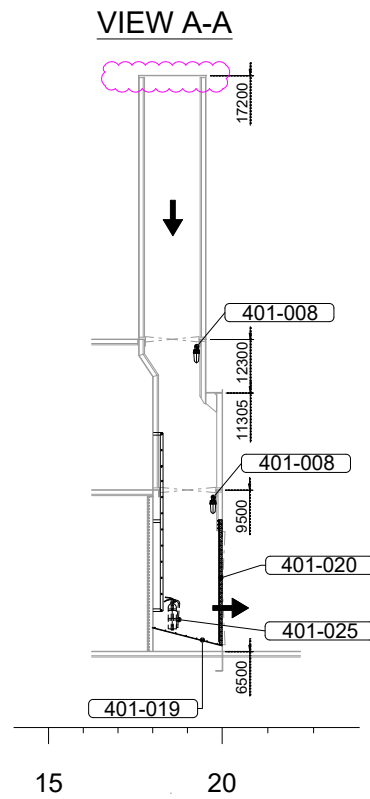
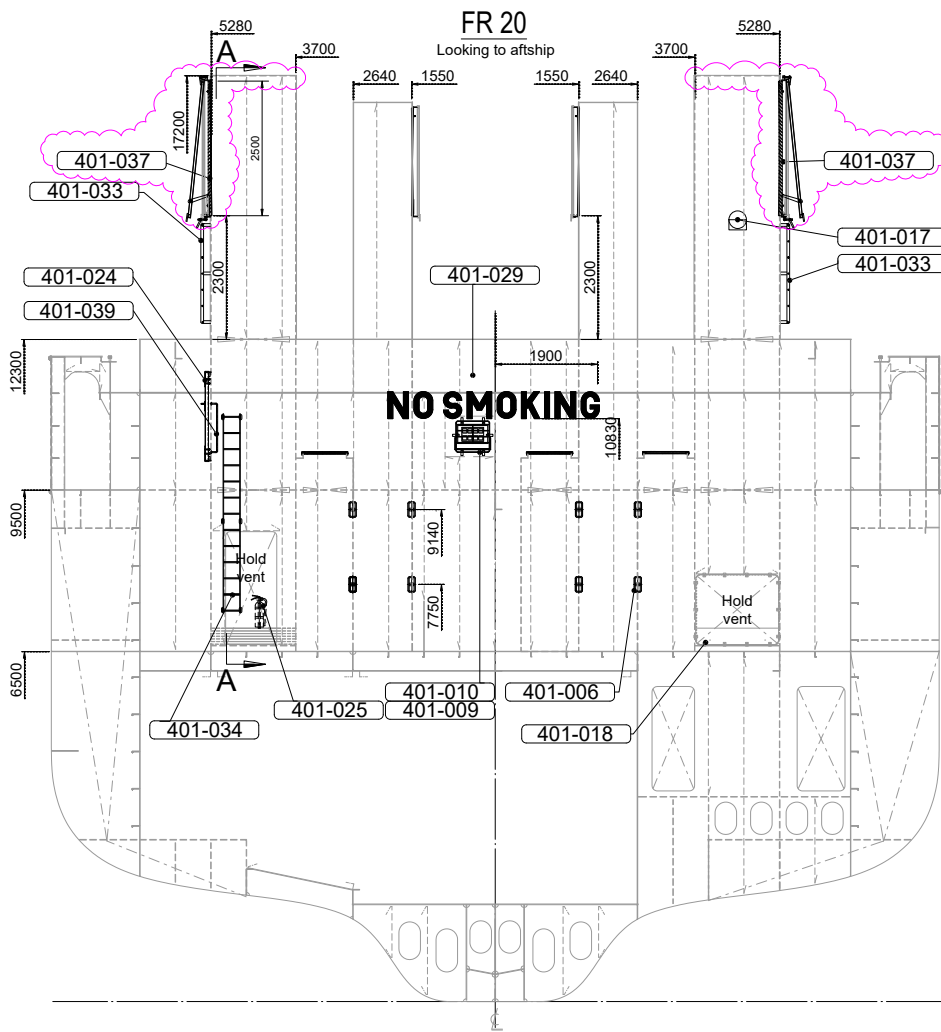

CROSS SECTION

REM. GRAIN BULKHEAD SIDE PINS

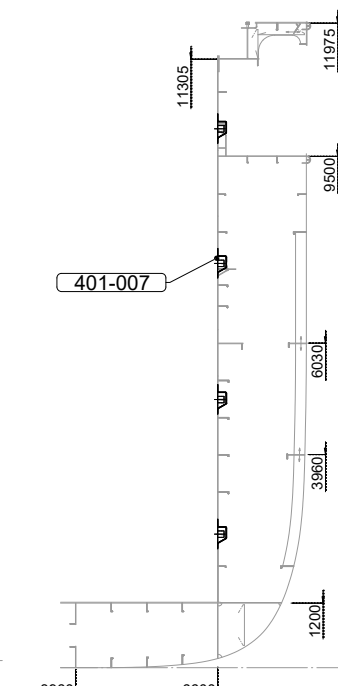
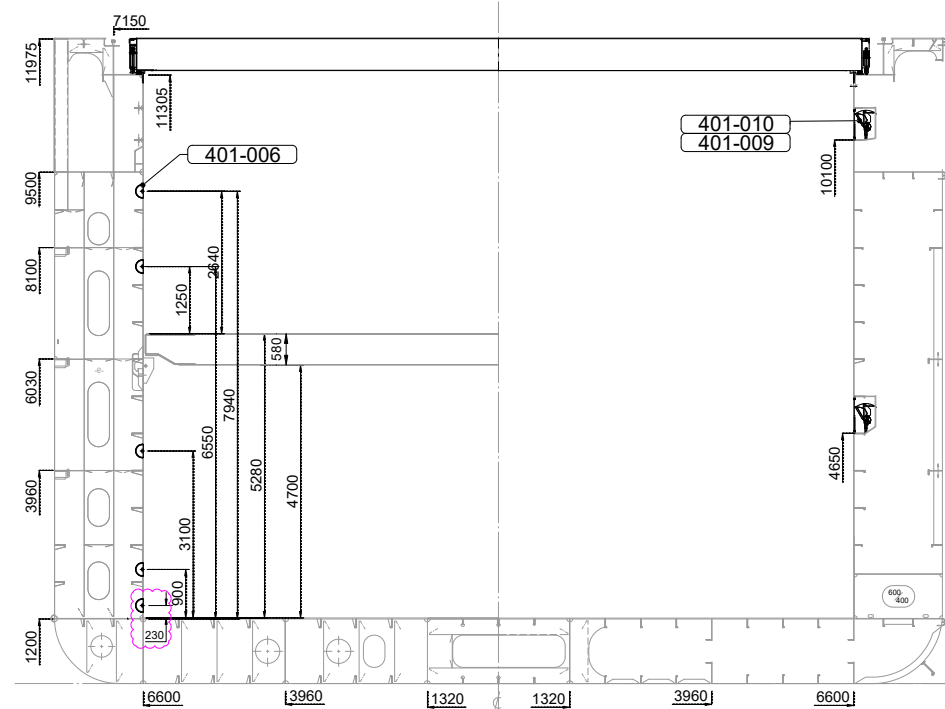
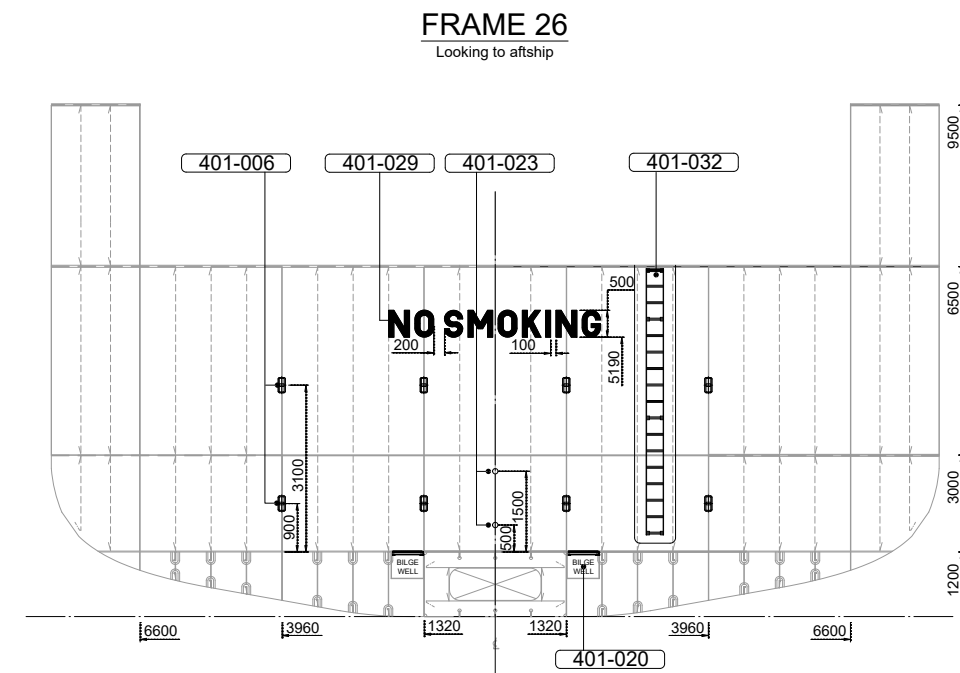

COCHIN SHIPYARD LIMITED
P.O. Box 1455, COCHIN-682015, INDIA



www.hs-schiffahrt.de
Competence shipping

Checked:	Checked:	Checked:	Checked:	Checked:	Checked:
Scale:	1:50	GSD No.:	P22003		
Drawn:	MR	Date:	09-06-2022		
Checked:	WN	Date:	10-06-2022		
Client: CARGO HOLD ARRANGEMENT					
Drawing No.: 7000MPP-100-401					
				Sh:	2/2
				Rev.:	B

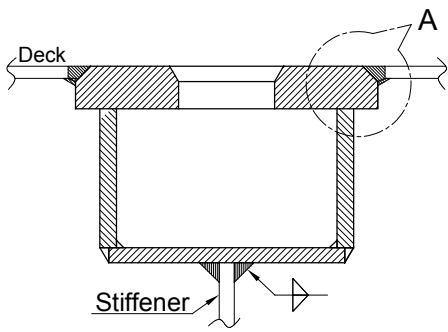

TYP. ARRANGEMENT OF LIFTING POCKET

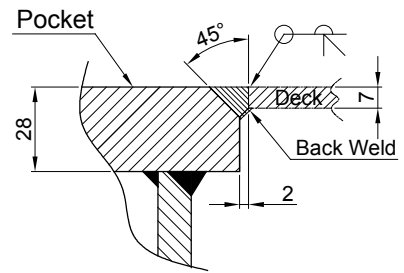

DETAIL - A

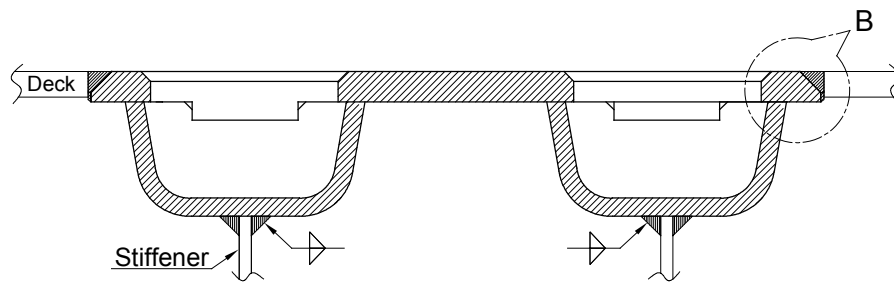

TYP. ARRANGEMENT OF DECK SOCKETS

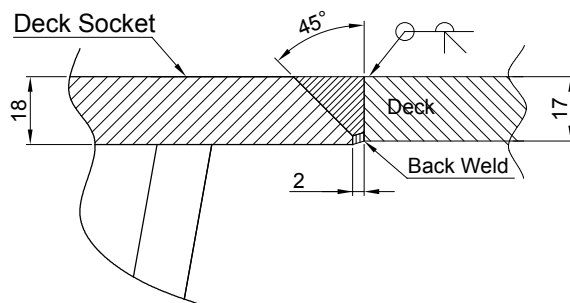

DETAIL - B

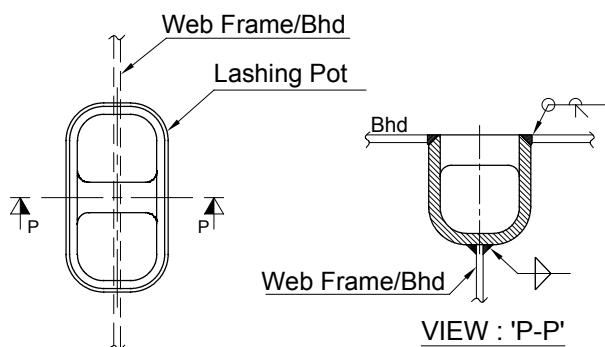

TYP. ARRANGEMENT OF LASHING POT

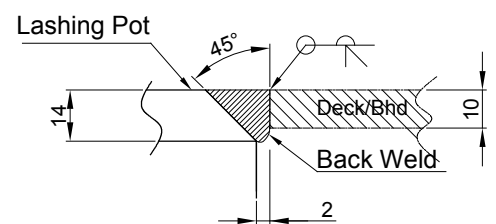

WELD DETAIL - LASHING POT

Vertical load caused by weatherload		Vertical load by hatchcovers		Divided per sliding block fore and starboard		Vertical load by containers resting by heave and pitch	
No horizontal load to be included	x	weatherload (kN/m ²)	Area (m ²)	Fv (kN)	middle	fore	25
Hatchcover 1	na	39,04	95,28589	2,44913174	388,0287	613,52124	511,306022
Hatchcover 2	na	35,8	94,10575	2,162257716	616,006	553,42124	0
Hatchcover 3	na	34,3	92,10566	2,0695134	548,601	586,6807	0
Hatchcover 4	na	34,3	92,10566	2,0695134	548,601	586,6807	0
Hatchcover 5	na	34,3	92,10566	2,0695134	548,601	586,6807	0
Hatchcover 6	na	34,3	92,10566	2,0695134	548,601	586,6807	0
Hatchcover 7	na	34,3	92,10566	2,0695134	548,601	586,6807	0
Hatchcover 8	na	34,3	92,10566	2,0695134	548,601	586,6807	0
Hatchcover 9	na	34,3	92,10566	2,0695134	548,601	586,6807	0
Hatchcover 10	na	34,3	92,10566	2,0695134	548,601	586,6807	0
Hatchcover 11	na	34,3	92,10566	2,0695134	548,601	586,6807	0
Hatchcover 12	na	34,3	92,10566	2,0695134	548,601	586,6807	0

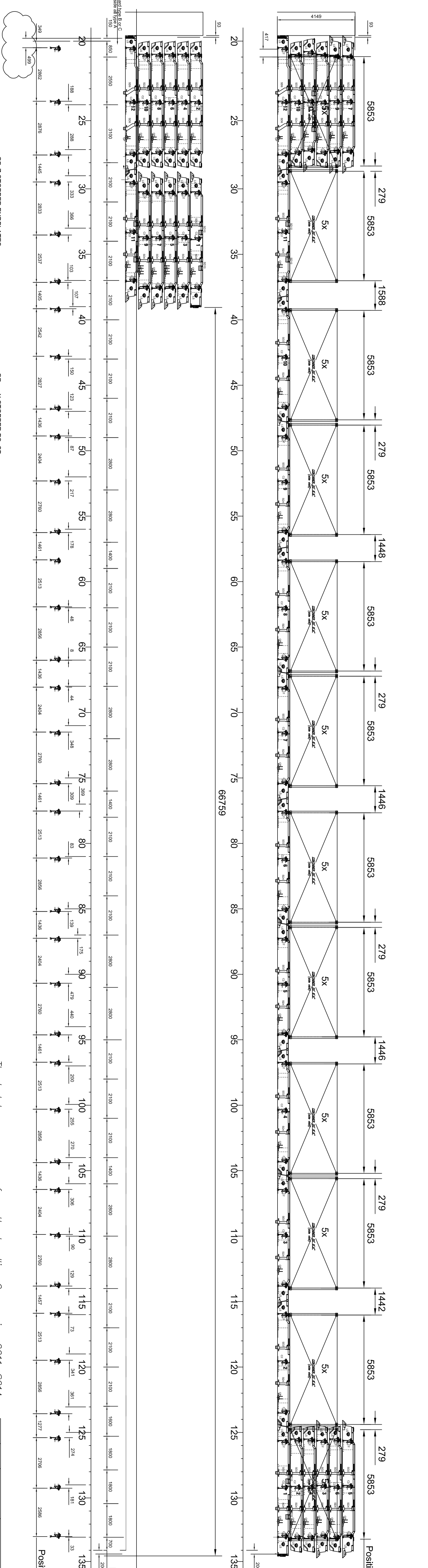
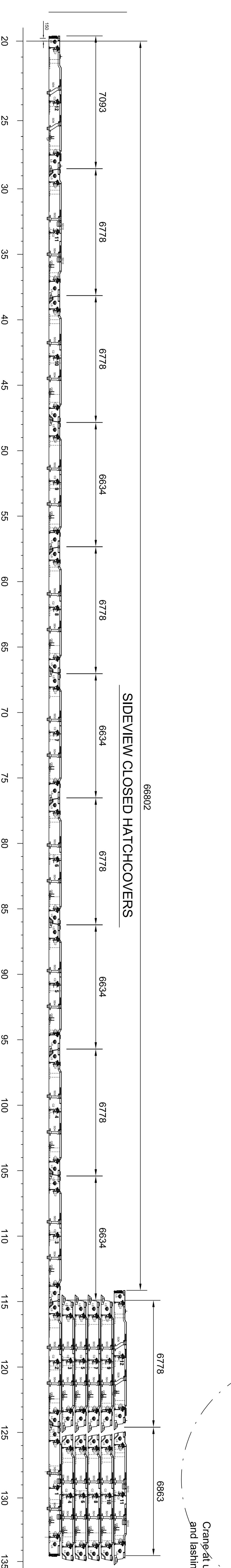
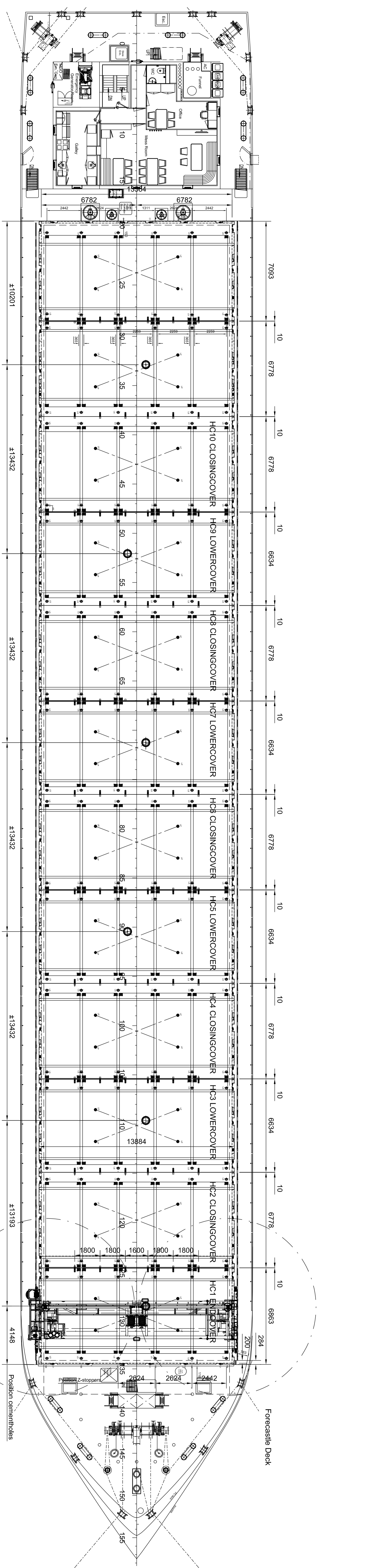

General arrangement Hatchcovers HS-Schiffahrt

YARD DRAWING NO.: P22003

YARD NO.: 001-1

SCALE: 1:100

DATE: 20-01-2020

CHECKED: [Signature]

TOLERANCE SYSTEM: DW 2300

FORM SHEET: A0

EDITION: F

Copyright by Konstruktivbüro/Coops & Nieborg B.V.

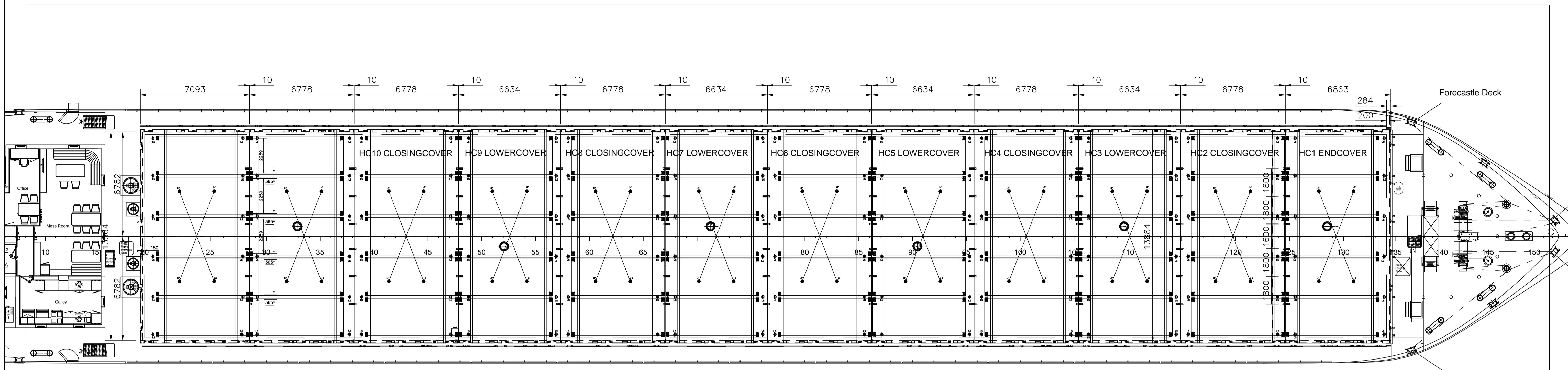

SIDEVIEW CLOSED HATCHCOVERS

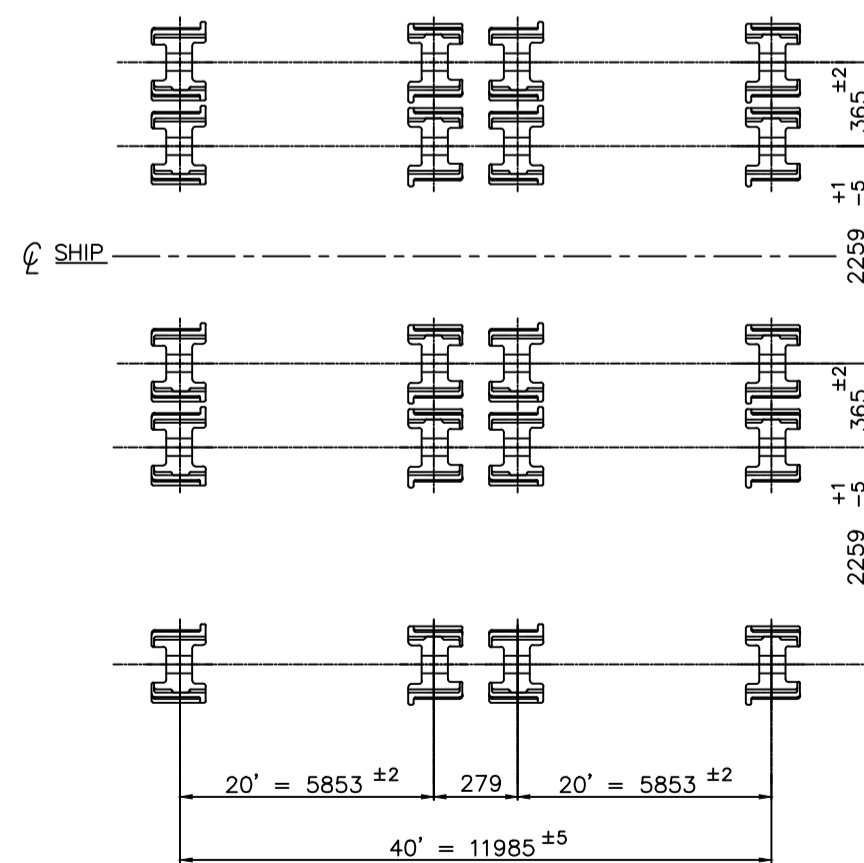
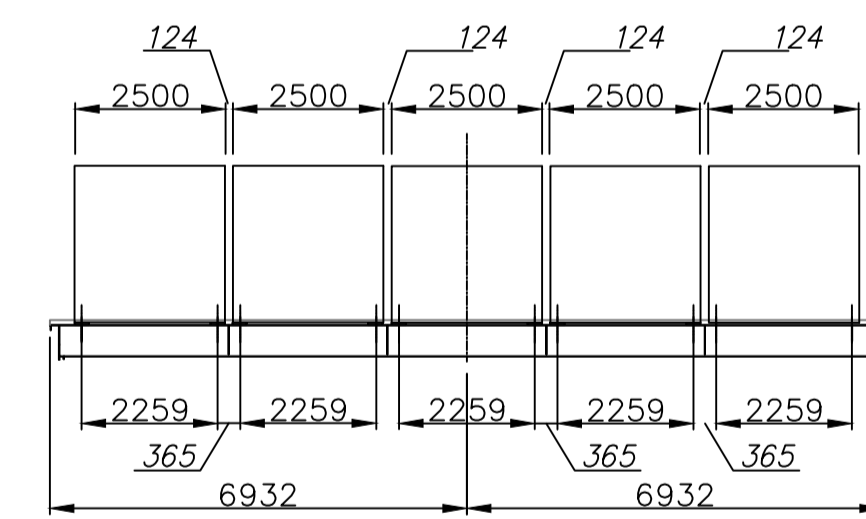
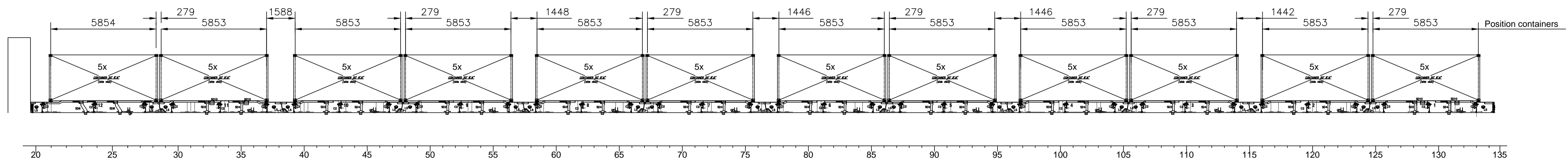

Detail container fitting ILS type DF-31-55
240x on maindeck hatches

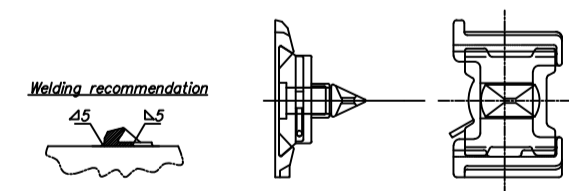

Detail pointload twistlock ILS BF-11-55 (del. yard)
240x on maindeck hatches

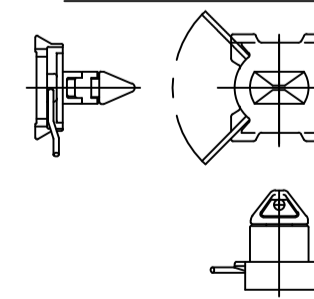

Detail pointload twistlock ILS IF-51 (del. yard)

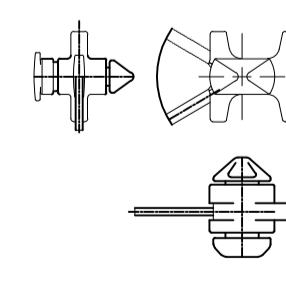

Lashing ring ILS
192x on maindeck hatches
Lashing ring LP14-50T
Lashing ring LP14

double plate 200x100x15
48x on sideplate
without double plate
144x on topplate

The hatchcovers conform the Loadline Convention 2011-S21A
Max cargo load 2.0T/m²
TEU-26T/FEU-52T

* Class: Bureau Veritas

ITEM No.	OFF No.	DWG No.	DENOMINATION	DIMENSION	MATERIAL	REMARKS
COOPS & NIEBORG BV			Container arrangement Hatchcovers HS-Schifffahrt	YARD DRAWING NO.: P22003	DRAWING No.: 002	SCALE 1:100
HOOGEZAND-HOLLAND						DRAWN-DATE ESS 30-08-2022
P.O. BOX 226 9600 AE Hoogezeand						CHECKED
TEL. 00-31-(0)598-395500 Fax. 00-31-(0)598-392427						TOLERANCE SYSTEM DIN 2310
E-mail: tekenkamer@coops-nieborg.nl www.coops-nieborg.nl			FORM SHEET	EDITION	A1	0

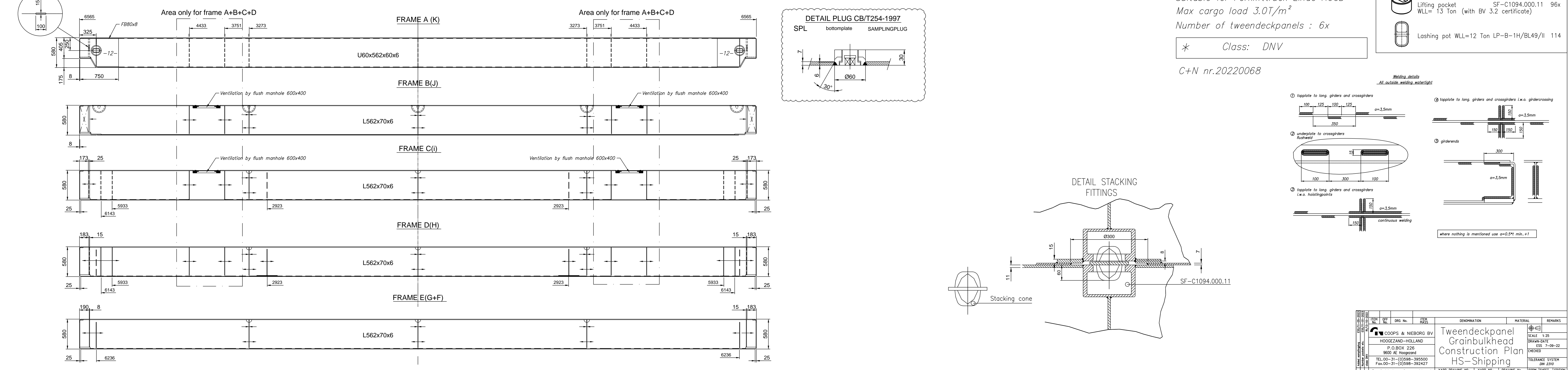
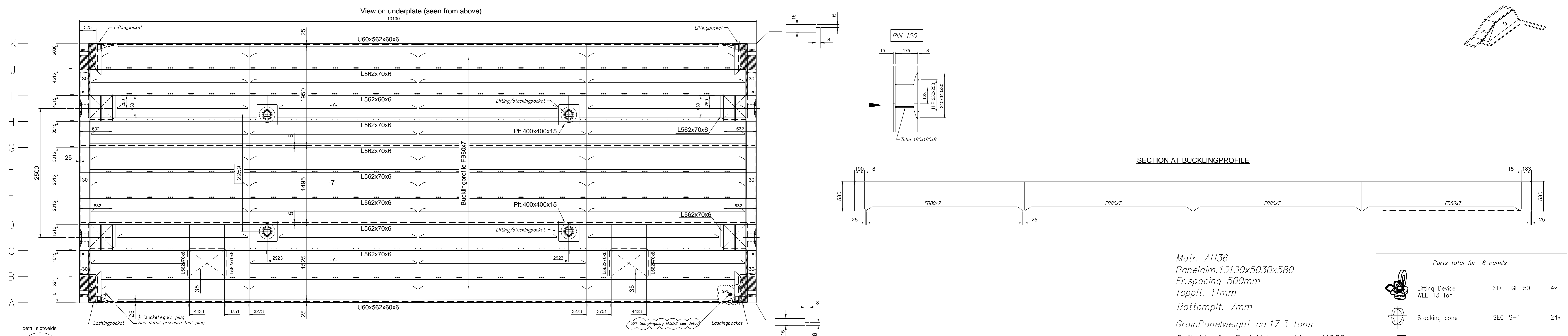
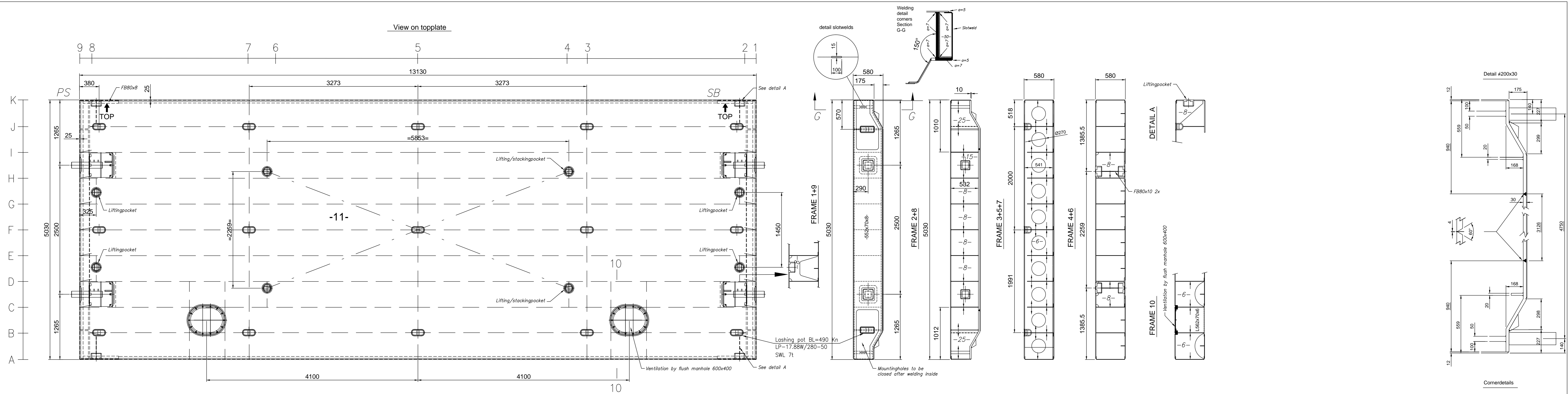

Matr. AH36
 Paneldim. 13130x5030x580
 Fr.spacing 500mm
 Topplt. 11mm
 Bottomplt. 7mm
 GrainPanelweight ca.17.3 tons
 Suitable for Forklifttruck Linde H60D
 Max cargo load 3.0T/m²
 Number of tweendeckpanels : 6x
 * Class: DNV
 C+N nr.20220068

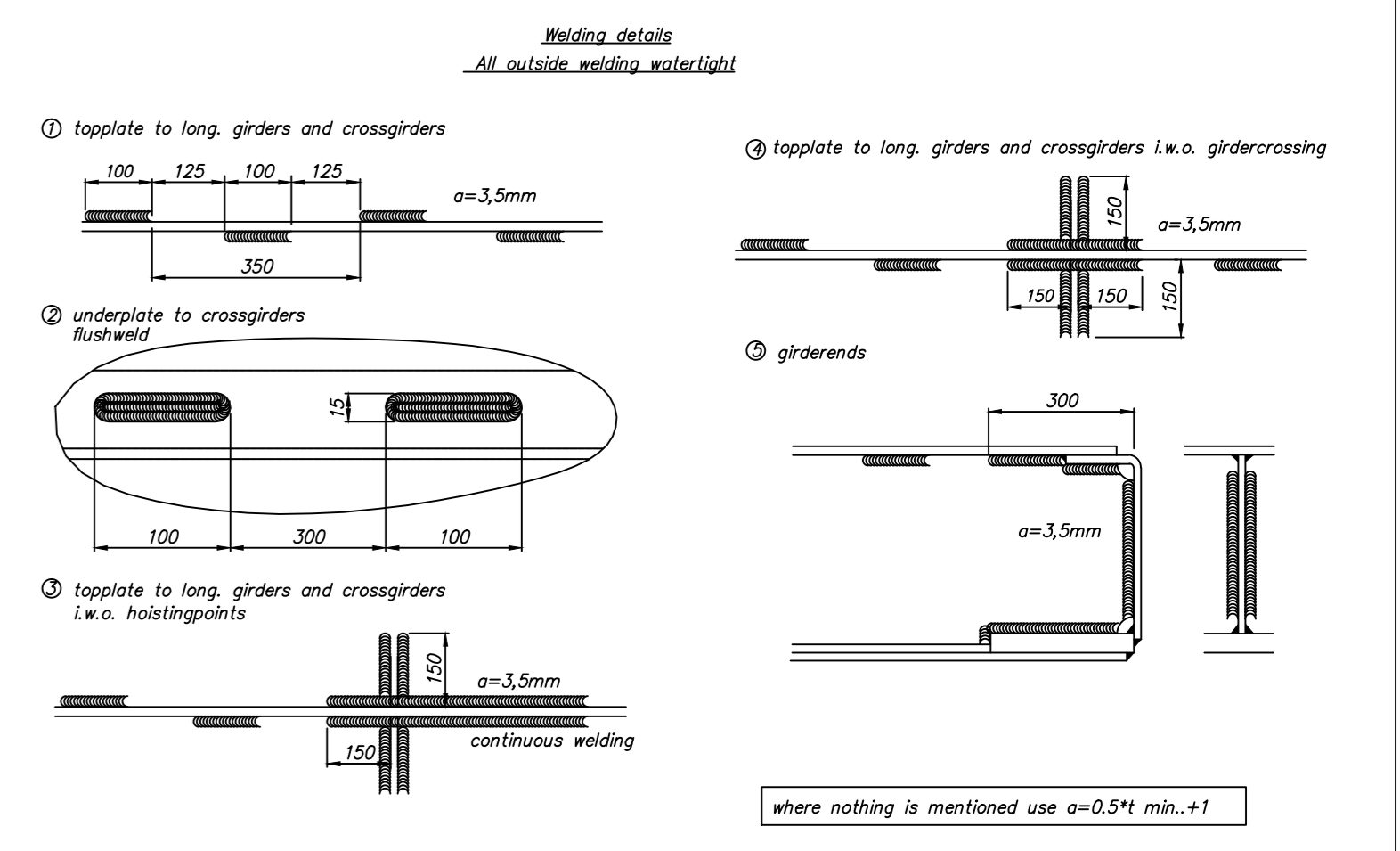

Parts total for 6 panels

	Lifting Device WLL=13 Ton	SEC-LGE-50	4x
	Stacking cone	SEC IS-1	24x
	Lifting pocket WLL= 13 Ton (with BV 3.2 certificate)	SF-C1094.000.11	96x
	Lashing pot WLL=12 Ton LP-B-1H/BL49/II		114



COOPS & NIEBOERG BV HOOGEZAND-HOLLAND P.O. BOX 228 8600 AE Hoogezand T: +31-(0)598-385500 F: +31-(0)598-384247 E-mail: Werkamer@coops-nieborg.nl www.coops-nieborg.nl	GENOEGENAMING Tweendeckpanel Grainbulkhead Construction Plan HS-Shipping	MATERIAL A0	SCALE 1:25	DATE 15-1-2022	REMARKS
TAB NO. P22003	TAB NO. 020	FORM SHEET A0	EDITION C		

Copyright by Konstruktief Buro Coops & Nieborg B.V.

REV. No.	REV. MARK	DESCRIPTION	DATE	SIGN
01		Updated as per design progress	03.01.24	



THIS DOCUMENT CONTAINS 03 PAGES

1
REV. Ø

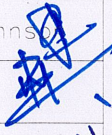
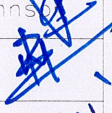

COCHIN SHIPYARD LIMITED

COCHIN - 682 015

YARD No.	SHIP 029-036	7000 DWT MULTI PURPOSE VESSEL	
OWNER	HS Schiffahrts Group		
APPROVED	Tony Johnson 	ARRANGEMENT OF TWIST LOCK POCKETS & LASHING POTS IN CARGO HOLD	
CHECKED	Raja M 		
DRAWN	Akhil K R 		
DATE	29.04.2023	Scale - - NTS	DRG. No. : Y20290328301001
ISSUED TO			
DEPT.			
No.			

ARRANGEMENT OF TWIST LOCK POCKETS & LASHING POTS IN CARGO HOLD

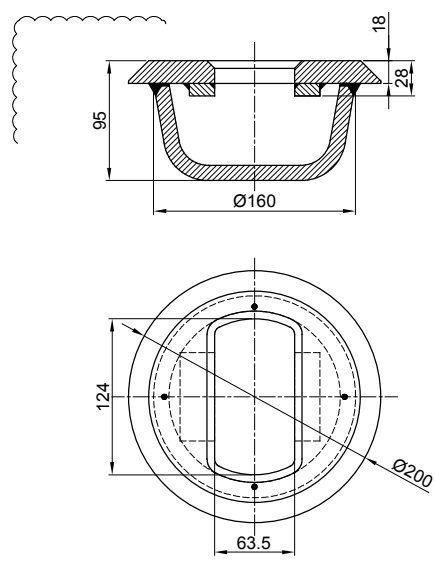

FLUSH DECK SOCKET : TYPE - A
 (Qty - 24 Nos.)

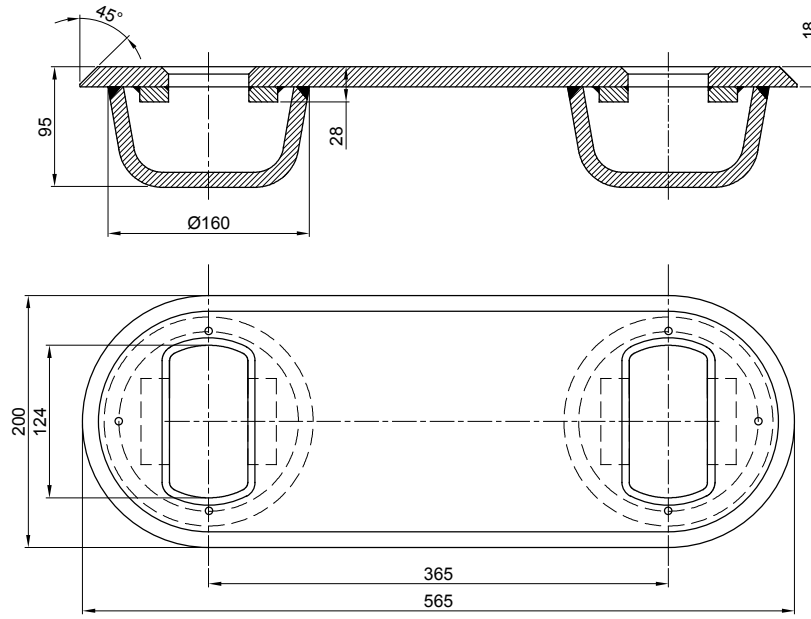

FLUSH DECK SOCKET : TYPE - B
 (Qty - 44 Nos.)

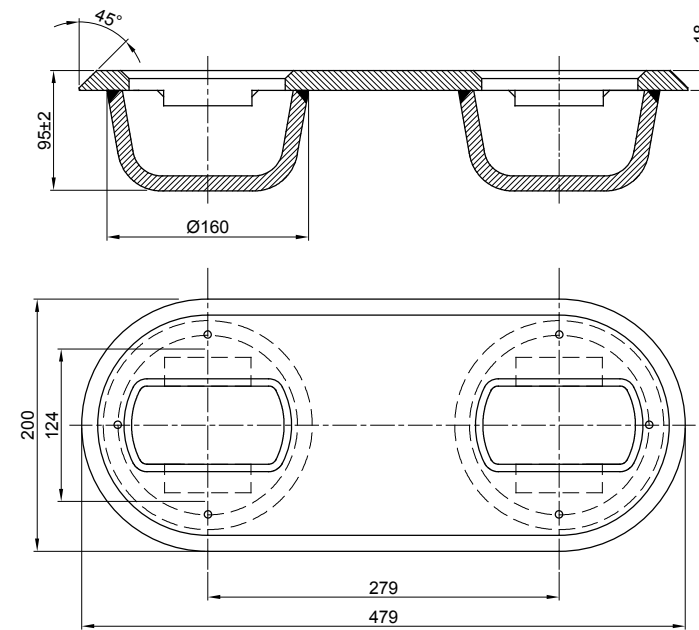

FLUSH DECK SOCKET : TYPE - C
 (Qty - 12 Nos.)

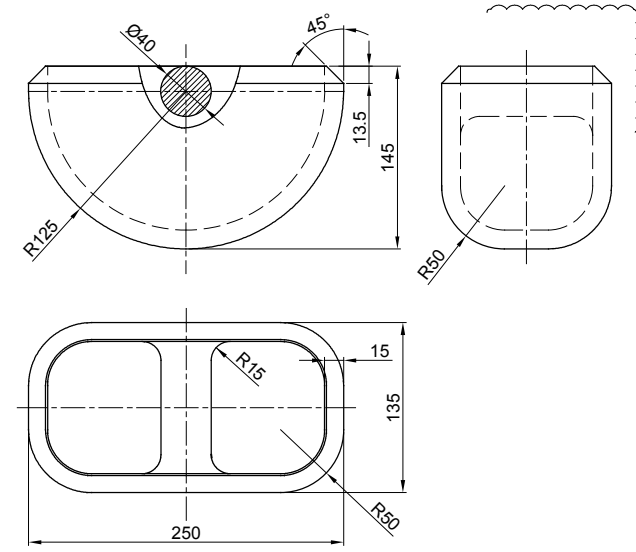

DETAIL OF FLUSH TYPE LASHING POTS
 (Qty - 244 Nos.)

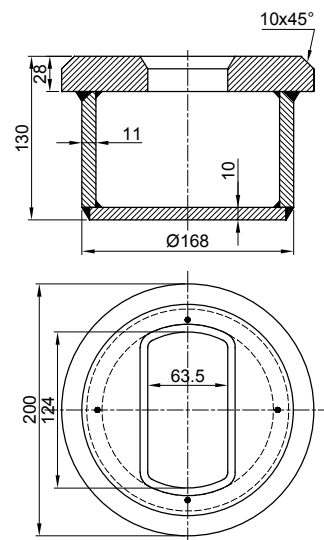

DETAIL OF LIFTING POCKET ON TWEEN DECK
 (Qty - 4 Nos.)

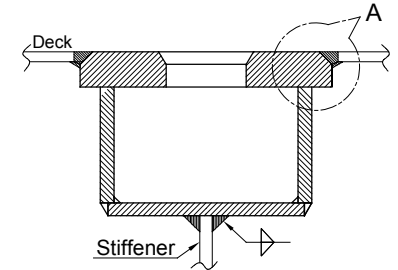

TYP. ARRANGEMENT OF LIFTING POCKET

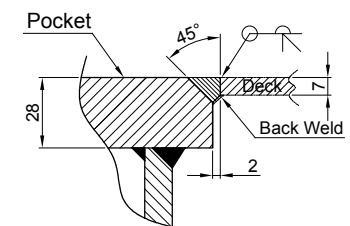

DETAIL - A

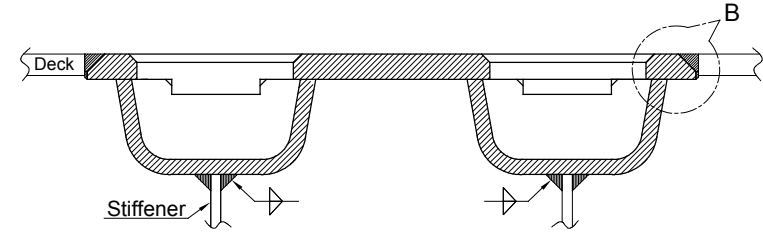

TYP. ARRANGEMENT OF DECK SOCKETS

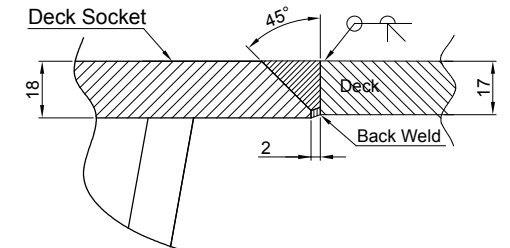

DETAIL - B

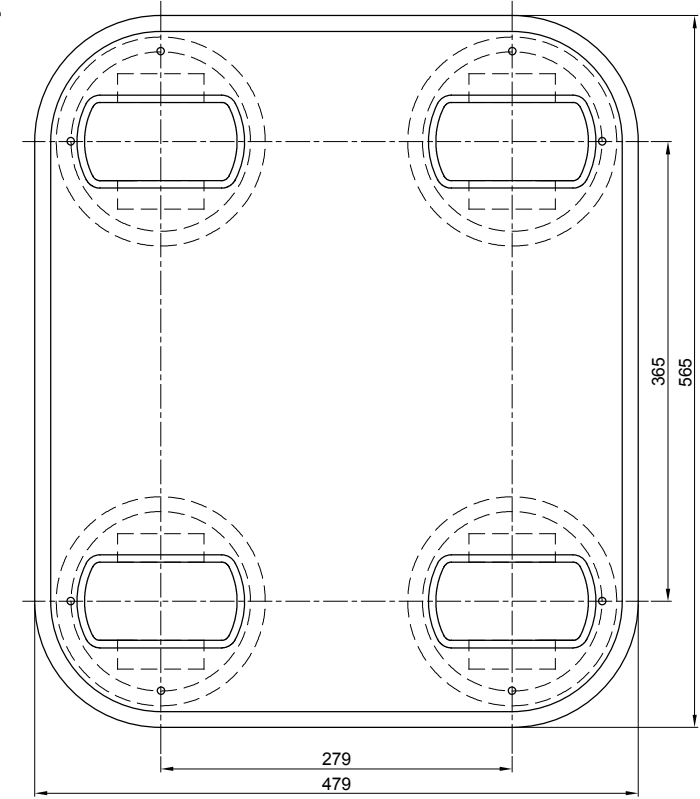

FLUSH DECK SOCKET : TYPE - D
 (Qty - 22 Nos.)

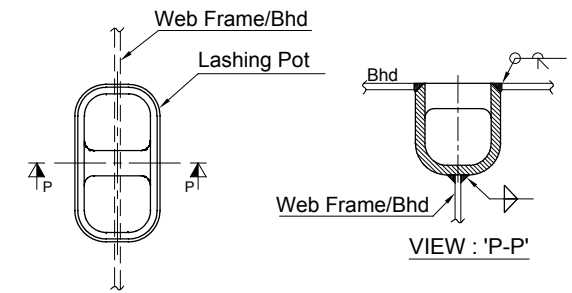

TYP. ARRANGEMENT OF LASHING POT

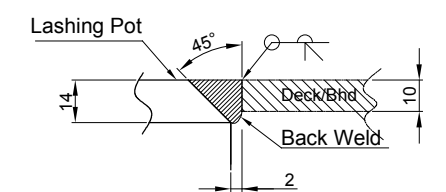

WELD DETAIL - LASHING POT

REF DWGS:

- I) Cargo Hold Arrangement : 7000MPP-100-401
- II) Container Plan : 7000MPP-070-001

NOTE:

- 1. All dimensions are in mm U.N.O
- 2. All welding shall be as per yard standard, unless specified . Welds in cargo hold to be executed "flush" with a height of max. 2 mm.

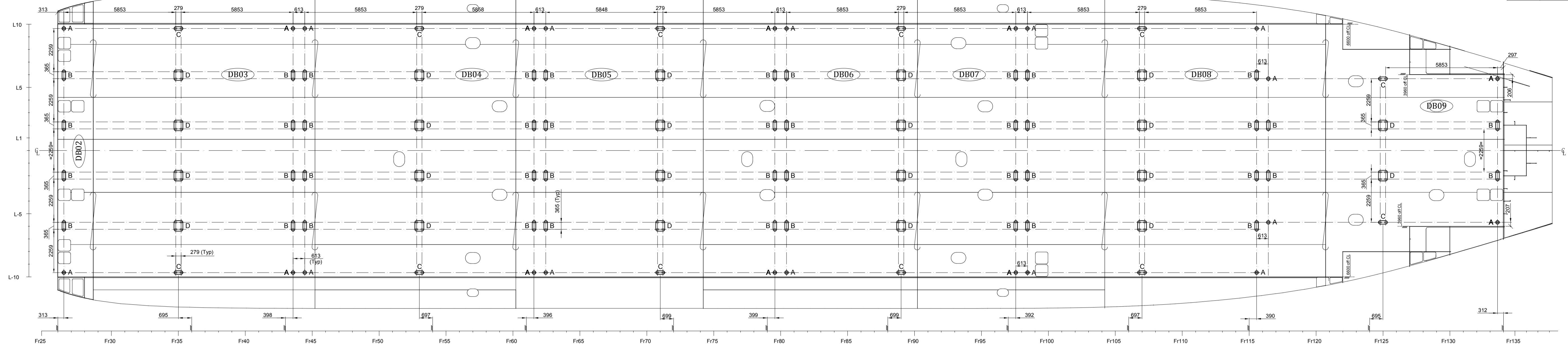

ARRANGEMENT OF TWIST LOCK POCKETS
 (Plan View at 1200 a.b)

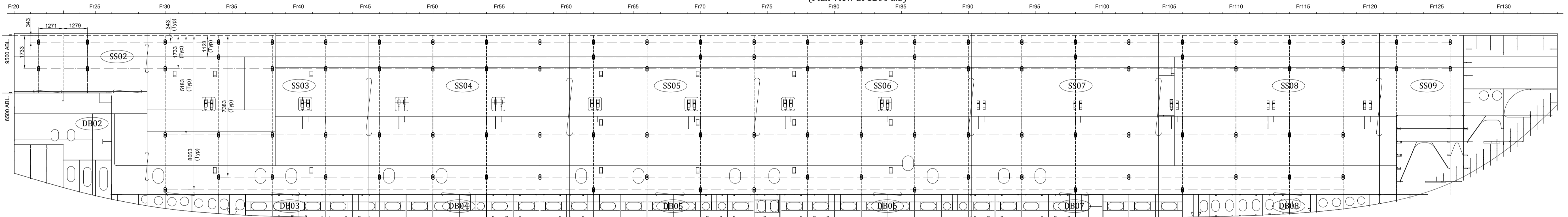

ARRANGEMENT OF LASHING POTS IN CARGO HOLD (PS SHOWN, SB SIMILAR)
 (Long. Sectional view at 6600 off CL (PS) - Looking PS)

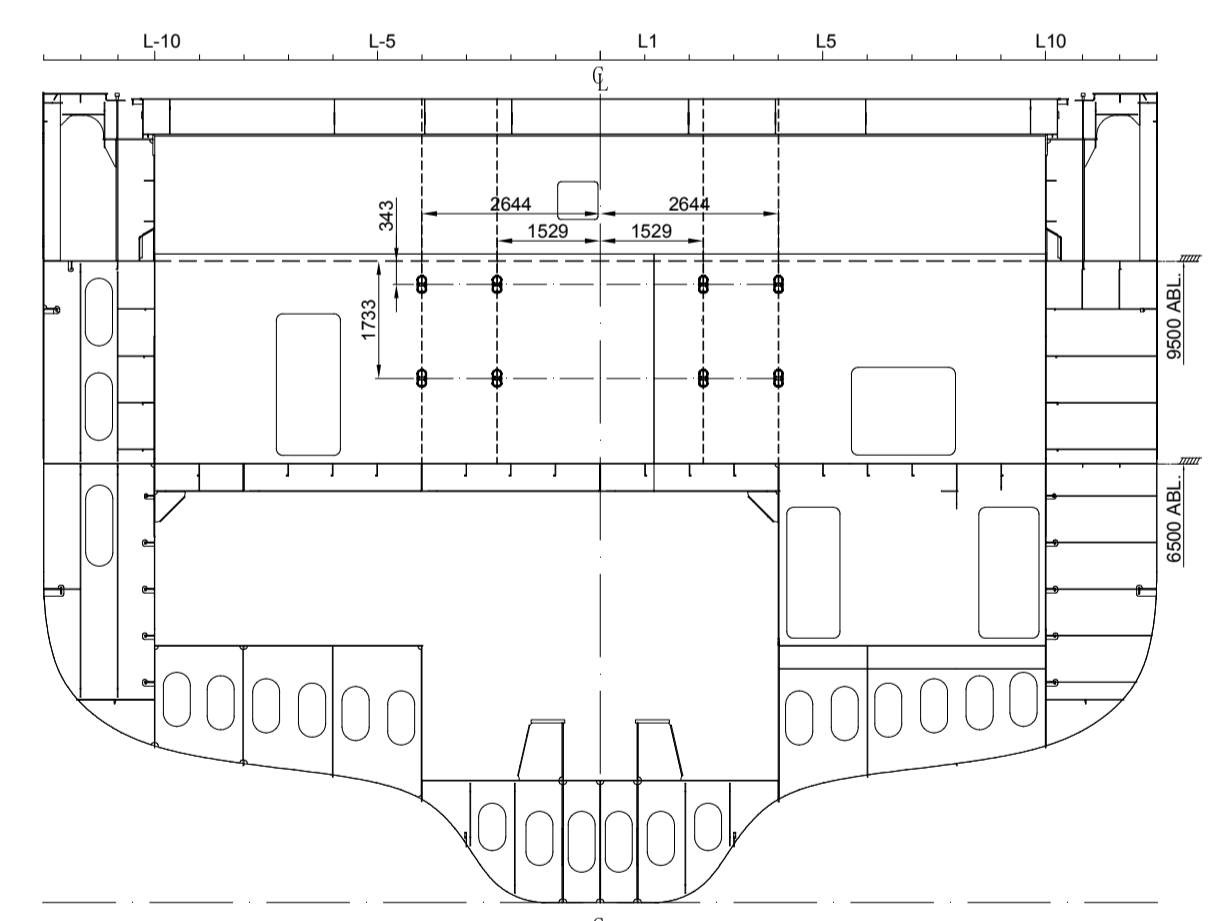

TRANS. VIEW AT Fr.20
 (Looking AFT)

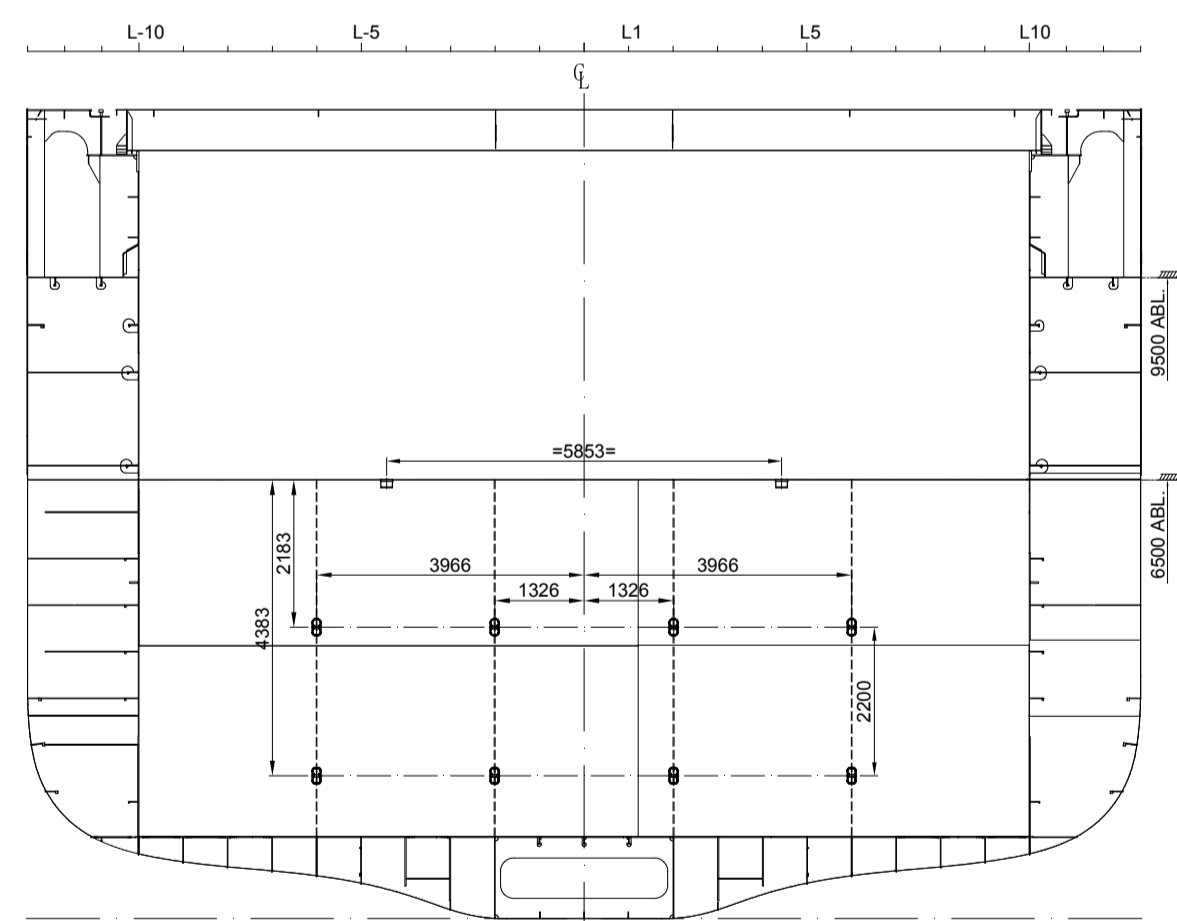

TRANS. VIEW AT Fr.26
 (Looking AFT)

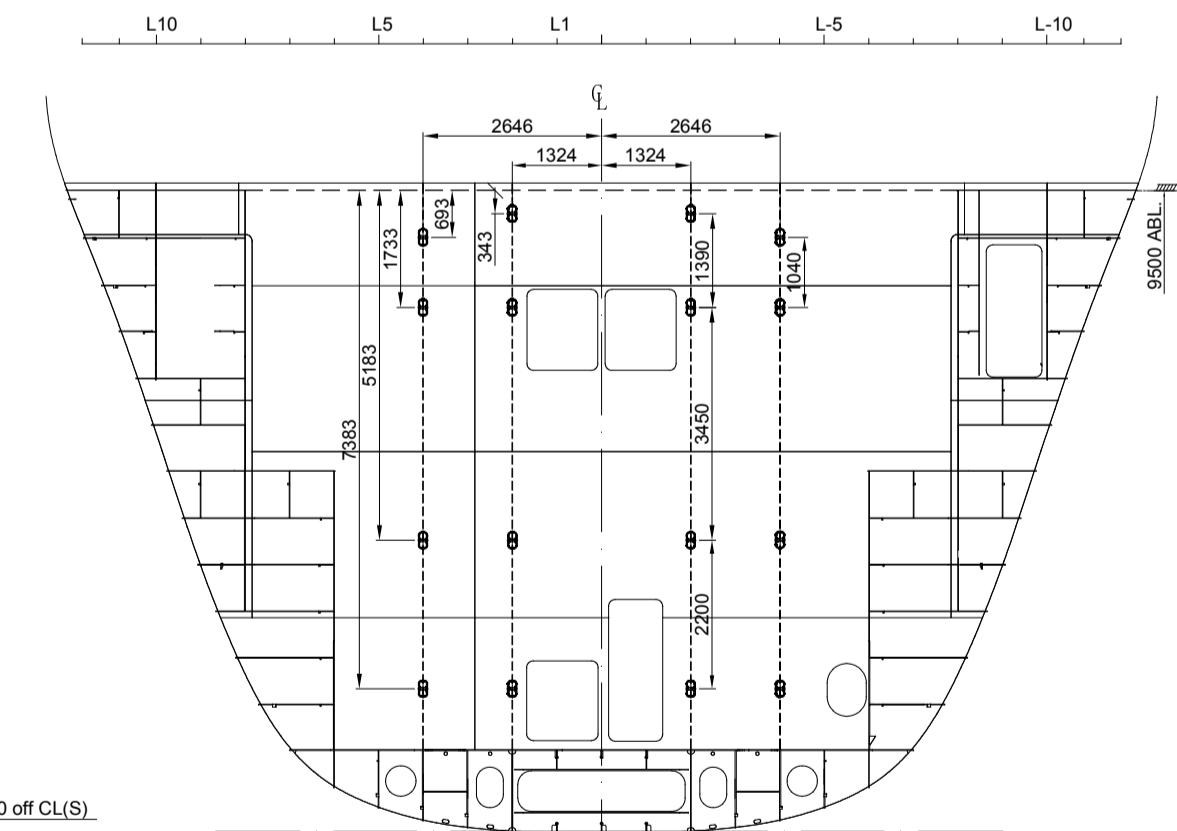

TRANS. VIEW AT Fr.134
 (Looking FWD)

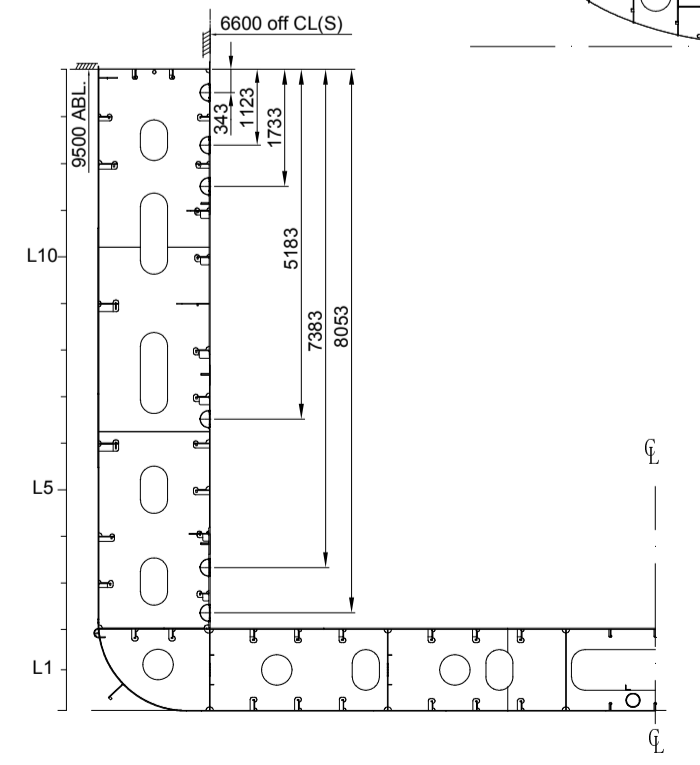

CROSS SECTION VIEW
 (SB Shown, PS Similar)

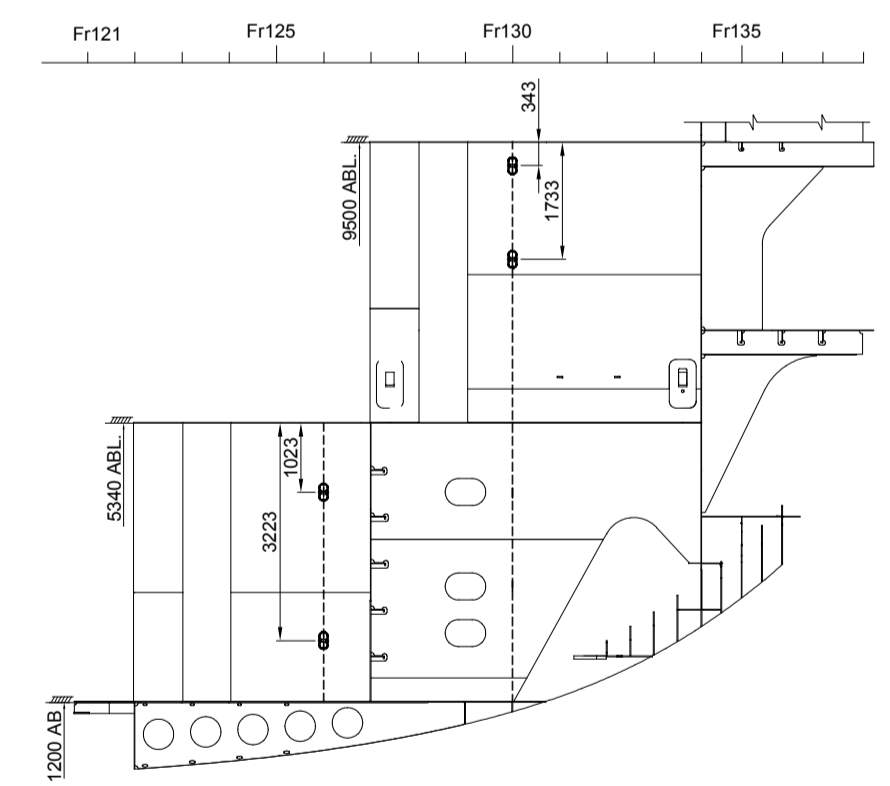

VIEW ON LONG. BHD 5280 off CL
 (PS Shown, SB Similar)

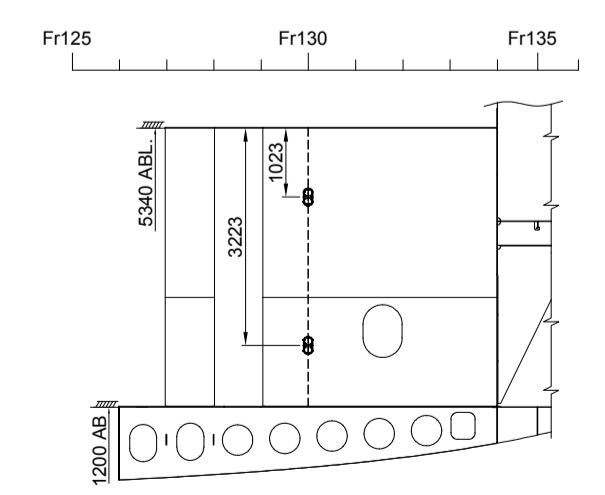

VIEW ON LONG. BHD 3960 off CL
 (PS Shown, SB Similar)

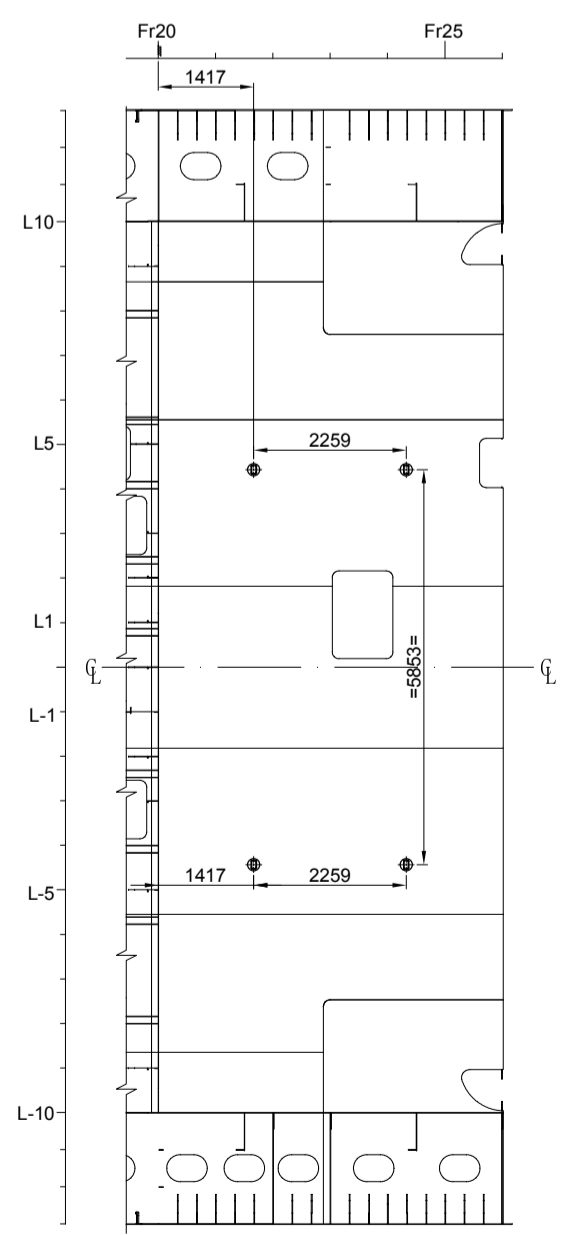

ARRANGEMENT OF LIFTING POCKETS ON TWEEN DECK
 (Plan View - 6500 ABL)

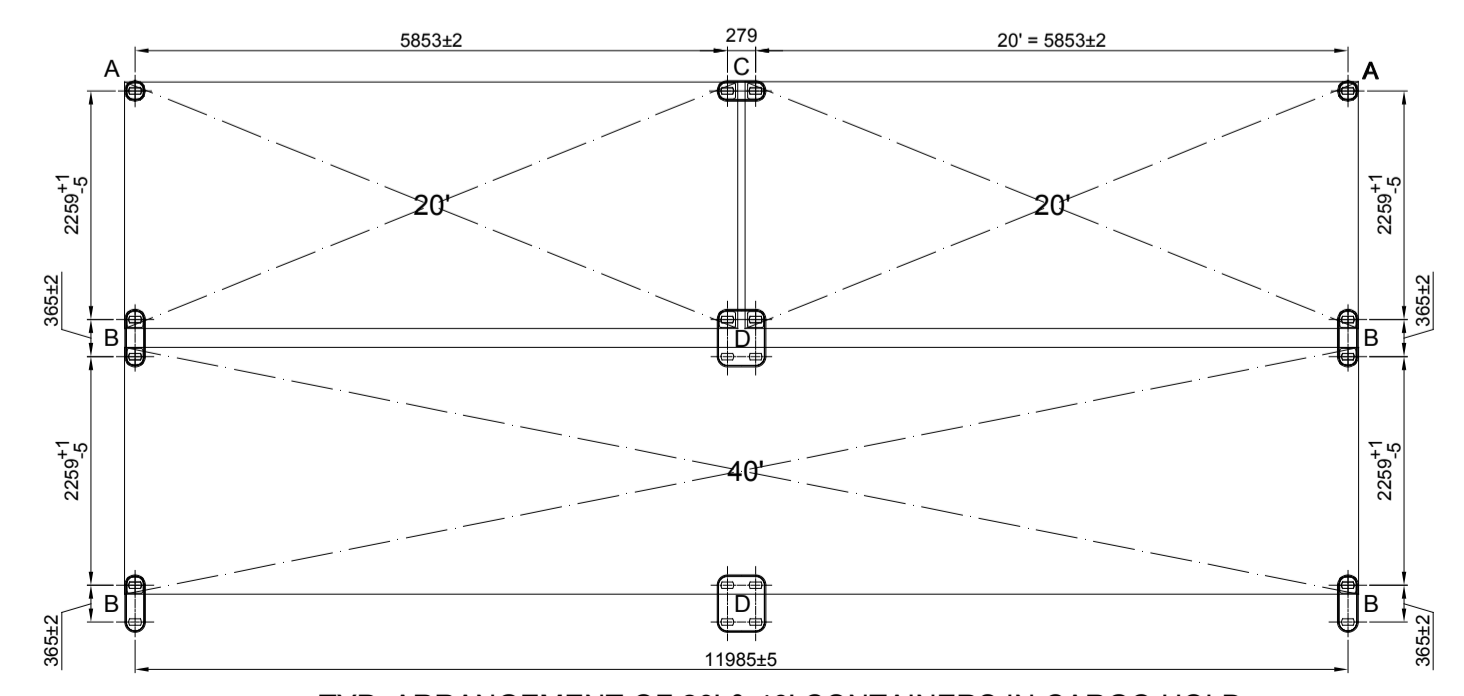

TYP. ARRANGEMENT OF 20' & 40' CONTAINERS IN CARGO HOLD