



**TENDER NOTICE**

सीएसएल – कोलकाता पोत मरम्मत यूनिट (सीकेएसआरयू), कोलकाता की ओर से निम्न सूचित कार्य के लिए अनुभवी फर्मों से मुहरबंद प्रतिस्पर्धी निविदाएं आमंत्रित की जाती हैं, ताकि निम्न सूचित तिथि और समय पर या उससे पहले अधोहस्ताक्षरी तक पहुँच सकें। कृपया संलग्न तकनीकी विनिर्देश, सामान्य नियम और शर्तें एवं अन्य अनुदेशों का संदर्भ लें।

Sealed competitive tenders are invited on behalf of CSL-Kolkata Ship Repair Unit (CKSRU), Kolkata from experienced firms for the under mentioned work, so as to reach the undersigned on or before the date and time mentioned below. Please refer to the Technical Specification, General Terms and Conditions and other instructions attached.

निविदा सं. व तिथि Tender No. & date	सीएसएल/सीकेएसआरयू/टीईएन/367/2024-25 दिनांक 22-07-2024 CSL/CKSRU/TEN/367/2024-25 dated 22-07-2024
कार्य का नाम Name of Work	सीकेएसआरयू, कोलकाता में क्षेत्र संघनन और प्रबलित सीमेंट कंक्रीट कार्य (विस्तृत विनिर्देश अलग से संलग्न है) Area Compaction and RCC Works at CKSRU, Kolkata (detailed specification is enclosed separately)
निविदा का प्रकार Type of Tender	<b>दो बोली</b> <b>Two Bid</b>
जमा करने के लिए बयाना राशि Earnest Money to be deposit	रु. 1,00,000/- Rs.1,00,000/-
निविदा प्रपत्र की लागत Cost of Tender Form	रु. 1,000/- Rs.1,000/-
निविदा प्राप्ति की अंतिम तिथि एवं समय Last date & time of receipt of tender	दिनांक 06-08-2024 को 16:00 बजे तक 06-08-2024 up to 16:00 hrs.
निविदा खोलने की तिथि एवं समय Date & time of opening of tender	दिनांक 06-08-2024 को 16:30 बजे तक 06-08-2024 at 16:30 hrs.
कार्य पूर्ण करने की अवधि। Work completion period	<b>03 महीना</b> (कार्य आदेश की स्वीकृति की तिथि से) <b>03 months</b> (from the date of acceptance of work order)

लिफाफे के ऊपर निविदा संदर्भ स्पष्ट रूप से सूचित किया जाना चाहिए।

Tender reference should be clearly indicated on top of the envelope.



उप महाप्रबंधक (सीकेएसआरयू) को संबोधित मुहरबंद निविदाएं सीएसएल- कोलकाता पोत मरम्मत यूनिट (सीकेएसआरयू), ड्राई डॉक ऑफिस बिल्डिंग, गेट नं. 9, नेताजी सुभास डॉक, सर्कुलर गार्डन रीच रोड, कोलकाता - 700024 में स्थित 'सीकेएसआरयू निविदा बॉक्स' में नियत तारीख एवं समय तक डाली जाएंगी। पासवर्ड से सुरक्षित निविदाएं निर्धारित प्रारूप में ईमेल के माध्यम से [poulam.chakraborty@cochinshipyard.in](mailto:poulam.chakraborty@cochinshipyard.in) पर नियत तारीख और समय तक भेज दी जाएंगी।

Sealed tenders addressed to The Deputy General Manager (CKSRU) shall be dropped in the "CKSRU Tender box" located at CSL-Kolkata Ship Repair Unit (CKSRU), Dry Dock Office Building, Gate No. 9, Netaji Subhas Dock, Circular Garden Reach Road, Kolkata -700024 by the due date and time. Password protected tenders shall be send via email in prescribed format to [poulam.chakraborty@cochinshipyard.in](mailto:poulam.chakraborty@cochinshipyard.in) by the due date and time.

उपरोक्त कार्य के लिए प्रभारी अधिकारी  
Officer In-Charge for the above work

नाम/ Name: पौलम चक्रवर्ती/ Poulam Chakraborty  
पदनाम/ Designation: एसपीओ (सिविल)/SPO (Civil)  
संपर्क सं. (मोब.)/Contact No (M): 9038104297  
ई-मेल/ E-mail: [poulam.chakraborty@cochinshipyard.in](mailto:poulam.chakraborty@cochinshipyard.in)

ठेकेदार का हस्ताक्षर एवं मुहर  
Signature and Seal of the Contractor (s)

कृते कोचीन शिपयार्ड लिमिटेड  
For Cochin Shipyard Limited

  
उप महाप्रबंधक (सीकेएसआरयू)  
Deputy General Manager (CKSRU)

## TABLE OF CONTENTS

<b>Sl. No.</b>	<b>Description</b>	<b>Annexure</b>
1	Scope of Work & Technical Specification	1
2	Price bid	2
3	General terms and conditions	3
4	Special Instructions for Two-Bid systems	4
5	Vendor Details	5

**Scope of Work and Technical Specification**

**1. Scope of Work & Technical Specification:**

The scope of work involves excavation, area compaction by roller, soling, PCC, reinforcement and RCC works at CKSRU, Kolkata. The work also covers the provision of necessary labour, materials, tools, and machinery required for the area compaction & concreting and also for the construction of a drain.

**a) Excavation and compaction**

The scope includes:

- i. Excavation by mechanical and manual means in all kinds of soil below the existing ground level by clearing and removal of materials such as steel scrap, wooden piece, rubble, trees etc., if any buried in the area of excavation including, all lift and lead required, as per site conditions. Appx. Size of excavation is 100m(L) x 30m(W) x 0.3m(D).
- ii. In case, depth of excavation increases, necessary shoring arrangements shall be ensured.
- iii. Disposal of excavated soil outside the CKSRU premises at the own expense of the contractor.
- iv. De-watering has to be done by the contractor, in case of a high-water table. Quoted price is inclusive of this.
- v. Proper compaction/ consolidation shall be achieved as per project requirement to ensure non shrinkage of soil even during the machinery movement (Especially crane movement).
- vi. Dressing of excavated area has to be done properly.

**b) Preparation of sub base (WMM)**

- i. The sub-base layer should be at least 75 mm thick and made of graded granular material such as crushed stone or gravel.
- ii. The aggregates used in WMM (Wet Mix Mecadam) should be graded as per the requirements of the project. The gradation should be such that the aggregates fill the voids and provide good stability to the area.
- iii. The water content in the mixture should be such that the aggregates are fully coated and there is no segregation during transportation and placement.
- iv. The sub-base should also be compacted to achieve a minimum of 95% of standard proctor density.
- v. The gradation should be such that the aggregates fill the voids and provide good stability to the road.
- vi. gradation tests, moisture content tests, and compaction tests should be conducted regularly to ensure that the WMM meets the required specifications.

**c) Reinforcement**

- i. The reinforcement steel used for the work shall be of TMT and minimum Fe500D/ Fe550D grade and confirming to IS 1786 and has to be sourced from TATA/JINDAL/SAIL/RINL/AMNS.
- ii. Providing and laying the Reinforcement at the edges of each panel at a spacing interval of 500mm for ensuring the edge strengthening.

- iii. Diameter of the reinforcement is 12mm. And also mentioned in drawings.
- iv. Length of each reinforcement is 500 mm.
- v. Supply of reinforcement, Bar bending, tying with GI binding wire, and keeping in position is included in the scope of work.
- vi. Providing and keeping in position of the cover blocks of required depth is necessary and included in the scope of work.

**d) Reinforced Cement Concrete (RCC)**

- i. Only Ready-Mix Concrete (RMC) of M25 grade is allowed for grade slab. Hand-mix concrete is not permitted. OPC 53 grade cement /PPC/PSG has to be used. And has to be sourced from Ultratech, ACC, Ramco, Dalmia.
- ii. The thickness of RCC is 200mm.
- iii. Grade slab shall be carried out in a panel manner by providing an expansion joint in between each panel. The size of each panel shall be 4mx5m.
- iv. Sealing the expansion joints by polysulphide sealant (12mm x25mm) so as to make the joint completely water tight.
- v. The contractor must submit batching plant test certificates for the concrete used.
- vi. The scope also includes providing and fixing the shuttering.
- vii. The slump test as per IS: 456 must be performed immediately after receipt of batching plant concrete.
- viii. Poured concrete must be vibrated appropriately with the help of a vibrator for proper penetration into all areas.
- ix. The concrete finish must be smooth and uniform without any honeycomb formation. A proper slope has to be maintained in RCC (1/4 inch per foot) so as to ensure all the water should smoothly flow into drain.
- x. 14 days of curing must be done on the concreted areas.
- xi. The Contractor should perform concrete cube testing of each batch of concrete received and other relevant tests, if any, at his own cost to ensure that the blocks meet the required specifications for strength, durability, and other properties.

**e) Construction of a Drain**

- i. A drain has to be constructed along the road side and has to be integrated with the existing drain of CKSRU office and SMP.
- ii. Construction of pits (if necessary, of appx. Size 1mx1mx1.5m)) for integrating with the existing drains also is included in the scope of the work.
- iii. 2 types of drains have to be constructed as per the Section X-X and Section Y-Y of the drawing attached at Encl-1.
- iv. Appx. length of drain as per the section X-X is 92 meters and as per the section Y-Y is 8 meters.
- v. Clear width of the drain is 400mm. Refer to the enclosed drawing (Encl-1).
- vi. M25 grade concrete has to be used for construction of the drain.

- vii. Drain has to be covered with reinforced cement concrete slabs (precast slabs) and lifting rings have to be provided on the slabs wherever necessary.

**Notes:**

- 1) A reference drawing is annexed as Encl 1A. Successful bidder to develop the detailed drawing and the same need to be approved by Officer In-charge.
- 2) All the materials, labour, tools & tackles, and machinery required to complete the job are in the scope of the contractor.
- 3) Transportation, loading, unloading, and associated expenses of all the supply items shall be in the scope of the contractor.
- 4) CSL shall have the right to propose changes/modifications to the indicated scope. The successful bidder must follow the instructions from CSL and execute the job without hindrances. Measurement shall be certified as per the final scope executed by the successful bidder.
- 5) Activities not indicated herein but required for completion of work are also included in the scope of the contractor.
- 6) Freshly laid concrete shall be protected by suitable covering during the rainy weather.
- 7) **Site clearance shall be given in a phased manner and the contractor has to execute the works accordingly.**
- 8) Tree cutting (if any) is also included in the scope of the work and rate quoted is inclusive of the same.
- 9) Bidder to visit and assess the work before participating in the tender.
- 10) All required testings at different stages of the work are to be performed by contractor at his own cost.

**2. Work Location:**

Cochin Shipyard Limited  
CSL-Kolkata Ship Repair Unit (CKSRU)  
Gate No.9, Netaji Subhas Dock  
Circular Garden Reach Road, Kolkata – 24

**3. Period of completion:**

The entire scope of work has to be completed within **3 months** from the date of acceptance of the Work Order.

**4. Eligibility criteria:**

The minimum qualification criteria for participating in the tender will be as follows:

- a) Experience having successfully completed Area compaction and RCC works during the last 5 years ending last day of month previous to the one, in which tenders are invited should be either of the following:

i. Three similar completed works each costing not less than the amount equal to Rs. 40 Lakhs.

OR

ii. Two similar completed works each costing not less than the amount equal to Rs. 50 Lakhs.

OR

iii. One similar completed work costing not less than the amount equal to Rs. 80 Lakhs.

(Details of orders executed along with completion certificate from the client indicating value of work executed and performance shall be submitted in this regard. The similar work should have been executed in India.).

b) The bidder should have an average annual turnover of Rs. 30 Lakhs in the last 3 consecutive FYs (FY21, FY22, and FY23). (Copy of audited balance sheets showing turnover and profit & loss account of the firm for the preceding 3 FYs should be submitted).

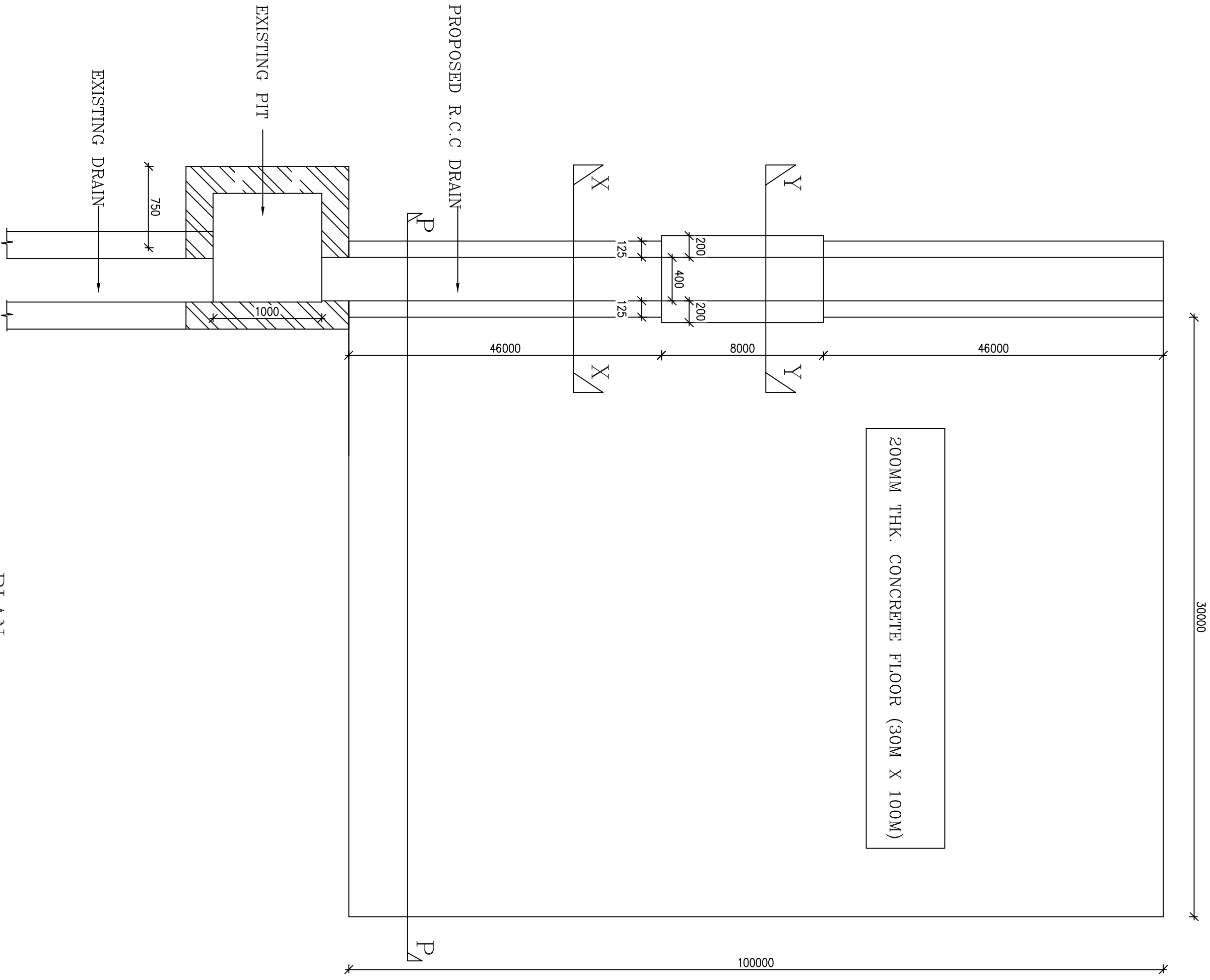

PLAN

<b>CLIENT</b>	COCHIN SHIPYARD LTD. (CKSRU) GATE NO.08, NETAJI SUHAS DOCK, KOL-24		
<b>PROJECT</b>	RCC FLOOR AND DRAIN		
<b>TITLE</b>	PLAN		
<b>SHEET:</b> A2	<b>DATE:</b> 11-08-23	<b>NAME:</b> AJI	<b>DATE:</b> 11-08-23
<b>SCALE:</b> -	<b>DRAWN:</b> J.A.MANINGER	<b>CHECKED:</b> J.A.MANINGER	<b>APPROVED:</b> [Signature]
<b>TITLE:</b> DMC No: 01/11009/CKSRU			



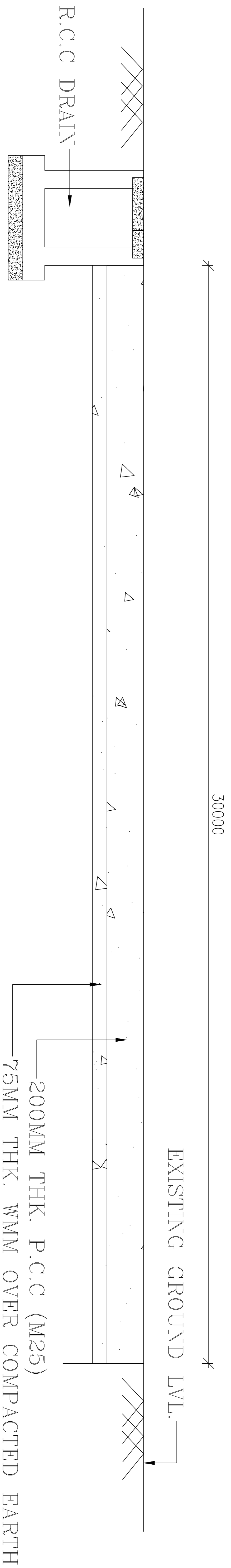

SECTION P-P

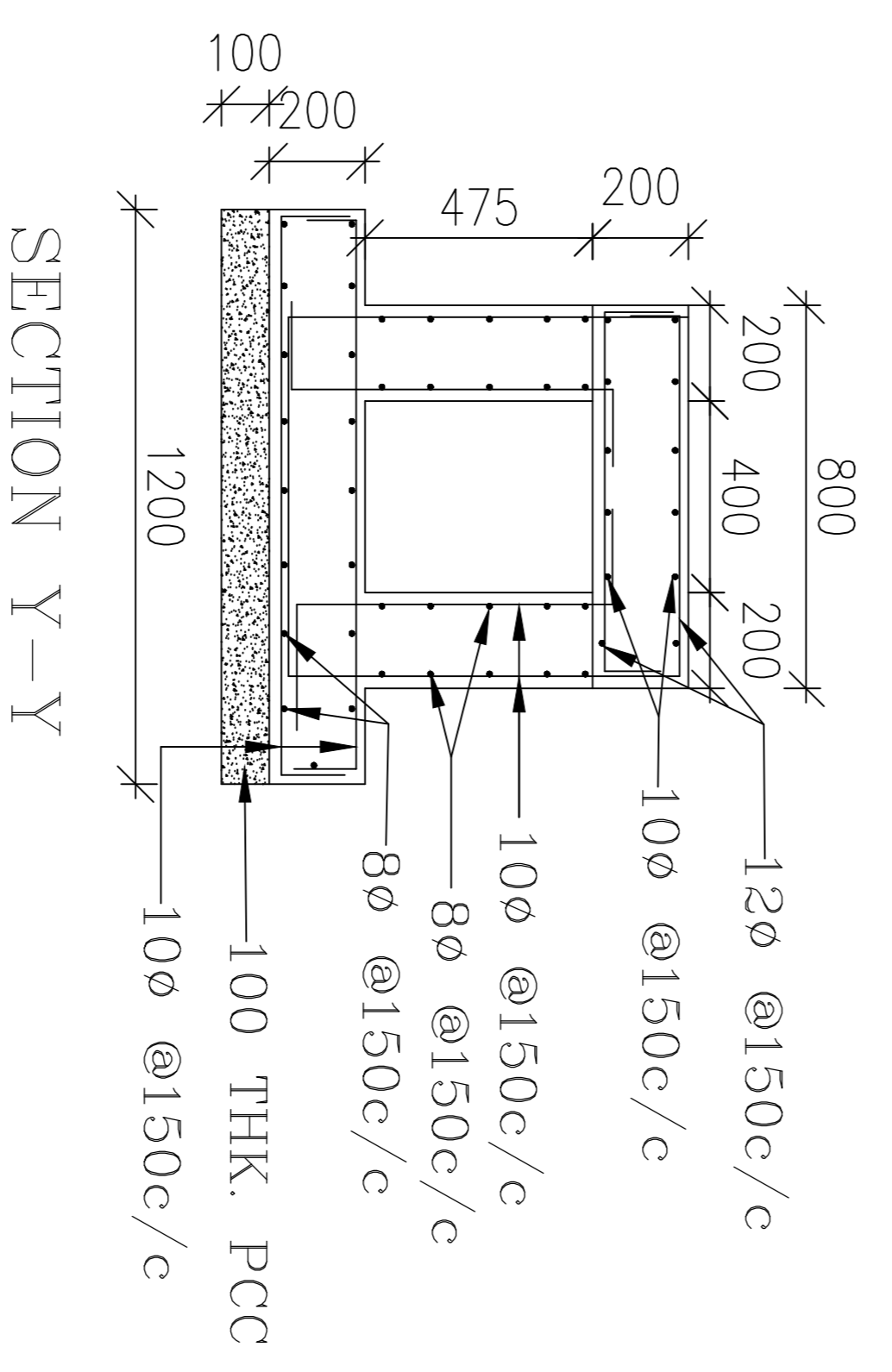
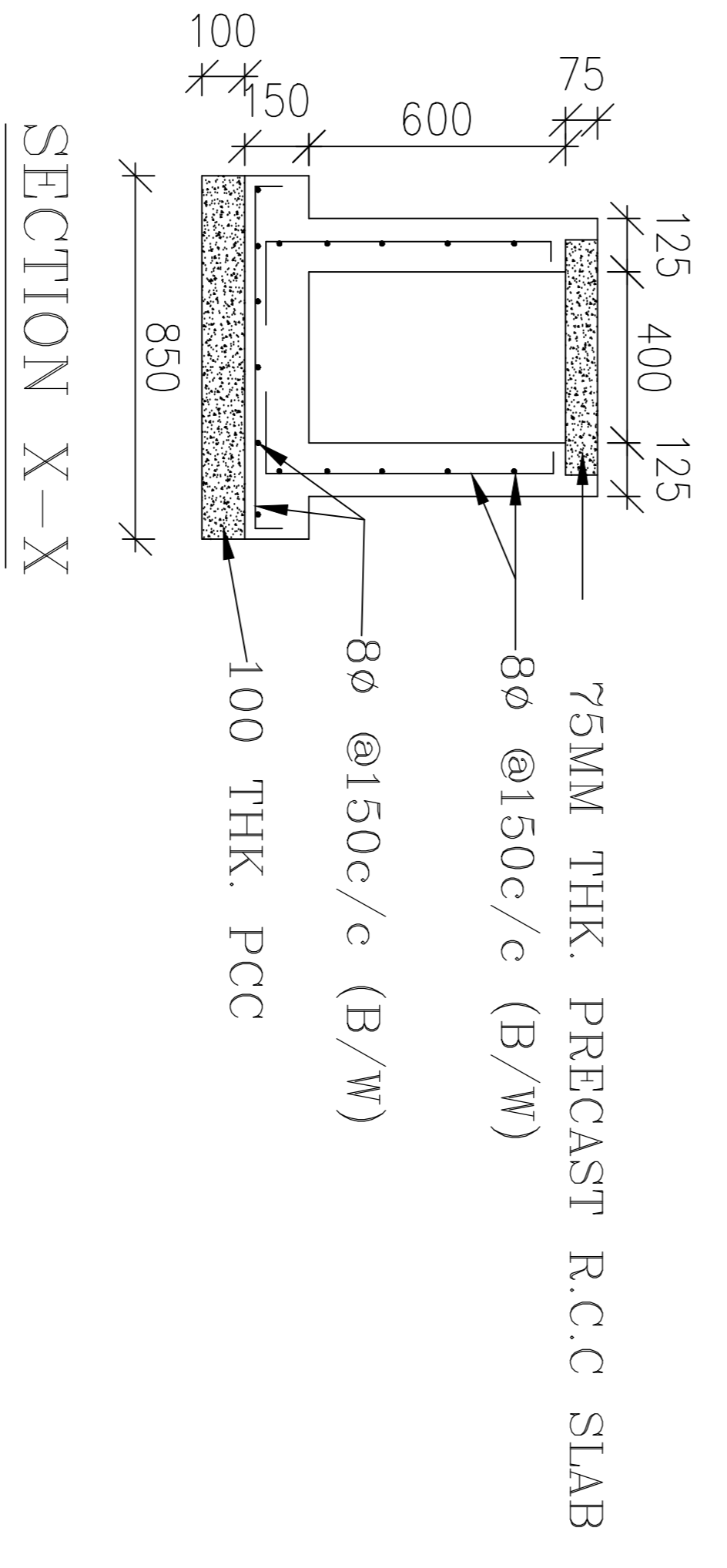

CLIENT	COCHIN SHIPYARD LTD. (CKSRU)	
PROJECT	GATE NO-09, NETPAI SUHAS DOCK, KOL-24	
TITLE	RCC FLOOR AND DRAIN	
SHEET:	A2	NAME
SCALE:	-	DATE
DRAWN	ALI	11-09-23
CHECKED	J.MAJUMDER	11-09-23
APPROVED		
TITLE:	DWG. No: 02/FLOOR/CKSRU	
Rev.		

Name of work: Area compaction and RCC works at CKSRU, Kolkata

Tender reference no: CSL/CKSRU/TEN/367/2024-25 dtd 22.07.2024

Sl.No.	Description of work	Unit	Qty	Unit rate (Rs)	Total rate excluding GST (Rs)	GST (%)	HSN/SAC code
1	Excavation of the Area (100mx30mx0.3m) & disposal of excavated soil including arranging of vehicle, loading, transportation and disposal as per the technical specifications indicated in the annexure-1.	CuM	1100				
2	Providing and laying 75mm thick single layer Wet Mix Mecadam (WMM) over the compacted earth as per the technical specifications indicated in the annexure-1.	CuM	250				
3	Providing and fixing reinforcement steel including supply, bending, tying, block setting, laying,etc along with Labour, materials & machinery as per the technical specifications indicated in the annexure-1.	Kg	3250				
4	Providing and placing in position the design mix M25 grade reinforced cement concrete with 20mm down graded coarse aggregates as per the drawing including supply and positioning of shuttering, de shuttering, mixing, placing, vibrating, dressing, curing etc along with Labour, materials & machinery as per the technical specifications indicated in the annexure-1.	CuM	685				
5	Providing and sealing the expansion joints (with the polysulphide sealant or equivalent materials. Size of joint 12mmx25mm) at each 4mx5m area intervals	Mtrs	1000				
<b>Total amount excluding GST (in figures)</b>							
<b>Total amount excluding GST (in words)</b>							

**TERMS AND CONDITIONS**

1. Tenderers are to carefully go through the terms and conditions and the technical specification of the items for which offers are called for
2. Offer shall be submitted in the prescribed form in the 'CKSRU Tender Box' located at CSL-Kolkata Ship Repair Unit, Gate No.9, Netaji Subhas Dock, Circular Garden Reach Road, Kolkata - 700024, and has to be addressed to The Deputy General Manager (CKSRU), Cochin Shipyard Limited, CSL-Kolkata Ship Repair Unit, Kolkata - 24.
3. In case of bid sent through e-mail, then the documents should be password protected and the passwords should be passed on to the concerned officer while attending the bid opening or by e-mail or SMS immediately before the tender opening against the request from concerned officer.
4. **Validity:** The offer should be valid for a minimum period of four months from the tender closing date.
5. **Earnest Money Deposit (EMD):** Rs.1,00,000/- (Rupees One Lakh only)  
EMD for a valid bid has to be submitted by the bidder in the form of demand draft / FDR / Bank Guarantee (Enclosure-2) drawn in favour of Cochin Shipyard Limited from scheduled bank except Co-operative bank in case of indigenous bidders and from international bank as per the CSL approved list in case of foreign bidder. Cheques are not acceptable. Bids submitted without EMD will be rejected. No interest shall be paid for the EMD, Security Deposit or Performance guarantee. EMD will be returned to the unsuccessful bidders post finalization of tender and issue of Work Order to the L1 bidder.
6. **Cost of Tender Form:** Rs.1,000/- (Rupees One Thousand only)  
Tender form cost has to be submitted by the bidder in the form of demand draft while submitting the technical bid, drawn in favour of Cochin Shipyard Limited from scheduled bank except Co-operative bank in case of indigenous bidders and from international bank as per the CSL approved list in case of foreign bidder. Cheques are not acceptable. This is a non-reimbursable amount.
7. **Mode of tender:** The tender for the work will be based on Two Bid system. The tender shall consist of below listed documents. Details are indicated at Annexure-4.
8. Bidders can contact Officer-in-Charge of the work which is indicated in the tender notice for any clarification before submitting the offer. If clarifications/details are not obtained before the offer is submitted, no claim on this account will be admitted.
9. Bidders to note that no advance payment will be made by CSL against work order/ supply order issued.
10. Corrections and additions if any in the bid must be attested/ duly signed by the bidder. In the case of error in multiplication/addition in amount calculated, the unit rate quoted will be considered as correct and the amount will be calculated accordingly. Conditional rebates & discounts, incomplete/ambiguous offers are likely to be rejected.
11. L1 will be arrived based on the lowest total amount quoted excluding GST.
12. Normally CSL will award the contract to the Bidder whose bid has been substantially responsive to the bidding documents and who has offered lowest evaluated total amount. However, if in the opinion of CSL, the total price or certain item rates quoted by the lowest evaluated bidder are considered high, CSL may invite such bidder for price negotiation. Lowest quoted bidder shall attend such negotiation meetings and if requested by CSL shall provide the

analysis of rates/break – up of amount quoted by him for any or all items of Schedule of Rates/ prices to demonstrate the reasonability. As a result of negotiation, bidder may offer rebate on his earlier quoted price.

13. No enhancement of rate for whatever cause will be allowed once the offer is accepted and an order is placed.

14. GST/Duties, if any, payable extra is to be indicated in the techno-commercial part for two bids.

**15. Payment terms:**

- a) 100% payment shall be released after completion of total scope of the work and acceptance by CSL representative at CSL site.
- b) Contractor shall indicate details like PAN, GST details etc. required for processing payment. Payments will be made through NEFT/RTGS/Cheque mode and necessary details shall be furnished by the contractor in the format at Enclosure-1.
- c) CSL reserves the right for the deduction of taxes and duties as applicable from the bill or invoice.
- d) The invoice to be raised on Officer in-charge, Cochin Shipyard Limited, CSL-Kolkata Ship Repair Unit, Dry Dock Office Building, Netaji Subhas Dock, Gate No.9, Circular Garden Reach Road, Kolkata – 700024.
- e) GST No. of CSL-Kolkata Ship Repair Unit is 19AAACC6905B1Z1.
- f) Payment will be released tentatively within 30 days from the date of submission of bill duly certified by the authorized CSL representative at Kolkata. Delay in submission of bills will lead to delay in processing of payment.

**16. Conditions on work part:**

- a) All materials required for use on works, shall be subjected to the approval of the Officer in-charge or his representative without which they shall not be used anywhere in the permanent works.
- b) The contractor shall bring all necessary machinery and equipment required for the work.
- c) Safety and Quality of the work to be ensured by the Contractor to the satisfaction of the employer. Contractor shall be solely responsible for non-compliance of the safety points and work may be stopped by the CSL. HSE guidelines issued by CSL from time to time shall be followed by the contractor.
- d) **Language:** All documents, instructions, catalogues, brochures, pamphlets, design data, norms and calculations, drawings, operation, maintenance and safety manuals, reports, labels on deliveries and any other data shall be in English language.
- e) Bidders can contact Officer-in-charge of the work which is indicated in the tender for any clarification before submitting the offer. If clarifications / details are not obtained before the offer is submitted, no claim on this account will be admitted.
- f) All applicable taxes, duties, transportation and insurance etc. should be included in the rate quoted, unless specified otherwise. CSL reserves the right for the deduction of taxes and duties as applicable from the bill or invoice.
- g) The Contractor shall also submit the Electronic Payment Mandate Form, as per Enclosure1 in their letter head duly signed by the respective authorized representative of the Bank with a cancelled cheque along with the Offer.
- h) Cochin Shipyard Ltd will not take responsibility for any liabilities caused by the contractor in respect of the vehicle's tax, insurance, road permit, accident, penalties by authorities etc., or will not compensate part or full whatever may be the reasons.

- i) The contractor shall be solely responsible for the consequences arising out of any loss, damage or accident caused by the contractor or the employee engaged by the contractor while on duty. Any labour issues with operators have to be settled by the contractor himself. CSL will not have any responsibilities for any issues between contractor and the operator.
- j) Speed limit inside CKSRU premises is Max 10km/Hr.
- k) The firm should not subcontract the work in part or full.
- l) Any loss / damage sustained by CSL on account of any negligent act of the contractor or the employee engaged by the contractor will be fully recovered from the contractor.
- m) The contractor or the employee engaged by the contractor are strictly banned from use of any kind of Narcotics drugs / Alcohol / smoking etc inside CKSRU yard premises and any illegal activity by the work men should be reported to the Officer-in-charge without delay and the contractor shall remove such persons from Yard premises.
- n) The Contractor shall ensure proper performance, conduct and behavior of the workforce engaged by him and any of the premises of the Company and shall remove with immediate effect, the engagement of such person(s), who does/do not give satisfactory performance, conduct himself/themselves properly and misbehave with the regular employees/personnel of the Company in any place.
- o) The Contractor shall ensure that the workforce engaged by him carry with them valid identity card to be issued him during the working hours.
- p) An attendance register of the Contractor's workforce shall be maintained by his supervisor or any other person as deployed by him.
- q) The Contractor shall reduce or increase the workforce as and when the exigencies of the work may require.
- r) The Contractor shall obtain appropriate licence under the Contract Labour (Regulation & Abolition) Act, 1970 and the Rules as amended up to date and shall comply with all terms and conditions thereof strictly, and shall keep such licence duly validated and/or renewed from time to time throughout the currency of the Contract.
- s) The Contractor shall produce all the registers and records to the representative of the Company and Government authorities as and when required for ensuring statutory compliance. The Contractor shall submit a Certificate for having complied with all the statutory provisions under all labour statute applicable to his contract at the end of the job period and only then his bill will be processed for payment by the Company.
- t) Contractor should take registration codes under Employees Provident Fund (Miscellaneous Provisions) Act 1952 and Employees' State Insurance Act 1948 for issuing PF number and ESI number to his contract workmen.
- u) The Contractor shall ensure that, to remit the Provident Fund and ESI contributions on before 15th of every month for the previous month wages as per the provisions of Employees' Provident Funds & Miscellaneous Provisions Act, 1952 & Employees' State Insurance Act, 1948. While submitting bills to the Company, the Contractor shall also render documentary evidence such as challan of remittance, transaction confirmation copy, etc. with an undertaking of the deposits of Provident Fund/ESI contributions made by him in respect of the workforce under consideration for payment of wages, failing which, the payment of the bill by the Company will be withheld until such compliance is met.

- v) The acknowledgment copy of the remittance statement shall be submitted along with bills for verification as per Statute and company policy.
- w) The Contractor shall ensure that the payment of wages to the workforce engaged by him is made to them keeping in view statutory provisions with reference to the payment of wages (including provisions of minimum wages fixed by the Central Government for each category) in presence of Company representative within stipulated time of the following calendar month.
- x) The Contractor's workforce shall be liable for security check by the Security Staff deployed by the Company as and when deemed essential. In case of any malpractice / theft is found, company has the rights to cancel the entry permit and to take suitable legal action against contractor personnel. Necessary action has to be taken by the contractor on the said personnel and details of such action should be intimated to the company officially within 3 days from the date of incident. In case of such repeated incidents from the employees of same contractor, company has the rights to take suitable action against contractor including cancellation of vendor code.
- y) The Contractor undertakes that it has complied with and agrees to comply with all the necessary statutory requirements such as maintaining Registers, Records and Returns under Contract Labour (Regulation & Abolition) Act, 1970, Factories Act, 1948, Minimum Wages Act, 1948, Payment of Wages Act 1936, Payment of Bonus Act, 1965, Employees' Provident Funds & Miscellaneous Provisions Act, 1952, Employees' State Insurance Act, 1948, Employees' Compensation Act, 1923, Labour Welfare Fund Act, 1987, The Industrial Employment (Standing Orders) Act, 1946 etc. as applicable to its business for providing the said services.
- z) In case, while on duty and during the course of engagement in the work premises of the Company under this contract, if any of the Contractor's workforce meet(s) with any injury/indisposition due to accident or other natural calamities, the Contractor shall ensure that immediate and adequate medical aid viz. First Aid and subsequent treatment facilities are provided to the person(s) concerned free of cost and without fail. In addition, the Contractor shall also be liable for meeting with statutory liabilities under the ESI/EPF or Employees' Compensation Act. In case, the Contractor is exempted from ESI coverage of his employees, he should be covered under Employees' Compensation Act or having suitable Group Accident Policy for his workers.
- aa) The Contractor shall indemnify and compensate CSL, if the Company as principal employer under the Contract Labour (Regulation & Abolition) Act, 1970 becomes liable to assume any liability towards the workforce engaged by the Contractor. In that event, the provisions relating to recovery as provided in the relevant clauses of the said Act shall be applicable.
- bb) Additional safety provision: For the work carried out within dock area the contractor shall abide by all provisions of the dock workers (Safety, Health and Welfare) Regulation 1990 without causing any damage / accident in the work premises which will be ultimately causing loss to CSL either directly or indirectly. The contractor has to take all the necessary safety measures to prevent any damage/ accident at site during the execution of work.
- cc) Port entry permit: Since the work is to be carried out inside the Port area, the contractor shall abide by all rules and regulations of the Port in force from time to time as applicable. The contractor is required to obtain required permit / RFID card for their manpower / vehicle as applicable issued by SMP to enter the CKSRU premises. The

necessary recommendations will be issued by CSL to permit the contractor to take the materials / equipment / vehicle inside / outside the dock area for the execution of the work.

17. **Force Majeure condition:** Should failure in performance of the contract or part thereof arise from war insurrection, restraint imposed by Government, Act of Legislature or other Statutory Authority or illegal strike, riot, legal lock-out, flood, fire, explosion, act of God or any inevitable or unforeseen event beyond human control which may be construed as reasonable ground for an extension of time, CSL may allow such additional time as is mutually agreed, to be justified by the circumstances of the case. The occurrence/ cessation of force majeure situation is to be informed with documentary evidence within 15 days from the date of occurrence/cessation.
18. It is clarified that the contractor cannot go for arbitration for any disputes arising out of the agreement related to this contract work. Cochin Shipyard Ltd. has a grievance redressal cell and all questions, disputes difference or differences arising under, out of, or in connection with the contract after hearing by Cochin Shipyard Ltd Grievance Redressal committee shall be subject to Indian Laws in force and at the exclusive jurisdiction of the courts at Kochi.
19. In case any disputes or differences arising under, out of, or in connection with the contract shall be subject to the exclusive jurisdiction of courts at Ernakulam, Kerala, India.
20. The acceptance of a tender will rest with DGM (CKSRU) who does not bind himself to accept the lowest tender and reserves the right to himself the authority to reject any or all of the tenders received without assigning any reason.
21. Local Suppliers (Make in India), MSME firms and Startups will be eligible for various Relaxations in pre-qualification criteria and other Benefits as per the orders promulgated by Government of India. Bidders are advised to refer the details of various benefits and relaxation in pre-qualification criteria as published at CSL website ([www.cochinshipyard.com](http://www.cochinshipyard.com)) under the Tenders tab for further reference.
22. **Guarantee Period:** The works performed shall be guaranteed for workmanship and satisfactory performance for a period of TWELVE (12) MONTHS from the date of date of issuance of work completion certificate. Contractor should rectify the defects immediately (within 10 days from the date of intimation of defect) after intimation of any such defects noticed during the Guarantee period and without any cost implication to CSL.
23. **Security Deposit/ Bank Guarantee:**
  - a) The successful bidder shall remit a security deposit of 3% of the total order value (excluding taxes, duties,) in the form of Bank Guarantee / demand draft drawn in favour of Cochin Shipyard Ltd towards the satisfactory performance of the contract, if an order is placed on them. Alternatively, a DD / Bank Guarantee equivalent to above % of the total order value (excluding taxes, duties) as per CSL format from an International Bank as per approved list of banks available in CSL website (for overseas supplier) & Scheduled Indian bank for Indian supplier/contractor is to be submitted within 14 days from the date of issuance of order, if an order is placed towards satisfactory performance of the contract.
  - b) The Bank Guarantee /DD as above should be initially valid till 90 days after completion of works in terms of SD and later revalidated (within the validity of initial BG) to cover the guarantee period indicated plus 90days. Fixed Deposit Receipt (for equivalent amount of Security Deposit/WBG required as per tender) in lieu of bank guarantee is also acceptable. Fixed Deposit Receipt shall be in the name of contractor with lien marked in favour of Cochin Shipyard Limited, Kochi.

24. **Risk Purchase:** If the contractor fails to complete the awarded scope of work within the delivery date or violate any of the terms and conditions of the purchase order, CSL shall have the following rights.

- a) To terminate the contract with 15 days' notice forfeiting the security deposit.
- b) To initiate alternate actions at the risk and cost of the Contractor.

25. **Liquidated Damage:** In case any delay in completion period beyond the stipulated completion period / delivery period, the contractor has to pay Liquidated Damage (LD), a sum equivalent to ½% (half percentage) of the order value per week or part of the week subjected to maximum of 10 % of the order value.

26. Products used shall be nontoxic and harmless to health. In the case of toxic materials Material Safety Datasheet may be furnished along with the material.

27. After submission of tender, no unsolicited correspondence will be entertained.

28. Cochin Shipyard Limited does not bind itself to accept the lowest or any tender but reserves to itself the right to reject any or all or a part of any tender at its discretion without assigning any reason.

\*\*\*\*\*



**COCHIN SHIPYARD LIMITED  
CSL-KOLKATA SHIP REPAIR UNIT (CKSRU)  
KOLKATA – 700 024**

**SPECIAL INSTRUCTIONS FOR TWO BID SYSTEMS**

**1. MODE OF SUBMISSION OF TENDERS**

Tenders should be submitted in two separate sealed covers superscribed in capital letters as PART-I "TECHNO-COMMERCIAL" & PART-II "PRICE" indicating the tender number, due date and name & address of the tenderer.

**2. TECHNO-COMMERCIAL PART SHOULD CONTAIN FOLLOWING DETAILS**

- a) Documents for minimum eligibility criteria
- b) Drawings & Technical Literature, if any
- c) Preliminary schedule (L2 level)
- d) Copy of unpriced Price bid (Price bid without price & with percentage of taxes & duties and details like quoted /Nil/Included need to be mentioned for each line item.)
- e) Complete set of tender documents duly signed and sealed on all pages as a token of acceptance.

**3. PRICE PART SHOULD CONTAIN FOLLOWING DETAILS**

- a) Duly filled price bid as per the tender document.
  - b) The quoted rate shall include rate for material, service engineer if required, transportation, loading etc. to deliver the items to the location as mentioned in the tender document.
4. CSL reserves the right to alter, modify the scope of supply at their discretion and consistent with the policy of the Government of India and statutory bodies under them as applicable to the contract from time to time.
  5. The techno-commercial part alone will be opened initially on the due date of tender. The price part will be opened only after evaluation of the Techno-commercial part. Firms will be intimated the date of opening of the price part, whose Techno-commercial bid is acceptable, in due course. Tenderers shall not be allowed to attend the Techno-commercial bid opening.
  6. The tenderer shall ensure that their Indian Agent is not representing any other suppliers for the same Tender. In other words, Indian Agents are not permitted to represent more than one firm for a particular Tender.
  7. After submission of quotation / price opening, no unsolicited correspondence will be entertained.
  8. Clarifications, either technical or commercial, should be submitted to points specially asked for only. The opportunity so given should not be used for correcting/changing/amending the data/conditions already submitted with the tender.
  9. Price part should be submitted in the Price Bid format provided. Price should be quoted separately for each item shown in the format. Combining of figures against more than one item and ambiguous clauses will lead to rejection of the bid. In case if there is any ambiguity in the price bid, unit rate quoted will be considered as base

and L1 will be arrived accordingly.

10. Offers should be clear and unambiguous. Incomplete/ambiguous offers are likely to be rejected.



**BANK GUARANTEE TOWARDS EMD**

To

COCHIN SHIPYARD LTD

(GOVT. OF INDIA ENTERPRISE,)

PO BAG No. 1653 , PERUMANOOR PO, COCHIN 682 015.

This deed of Guarantee made on ..... Day of .....Two Thousand .....between CSL on one part and ..... (Name and address of the bank) of the other part is as follows:

In consideration of CSL having allowed M/s. ....(herein after referred to as ‘the Contractor’) to submit Tender No.....without Earnest Money according to the conditions of such Tender Notification, we... (Name of the Bank) (hereinafter referred to as ‘the bank’) undertake to pay to CSL on demand the sum of money payable as Earnest Money in respect of the Tender Number.....made by the contractor in case the contractor withdraws from the tender before the date of firmness stipulated or when the tender is accepted by CSL, the contractor makes default in furnishing the Security Deposit or in entering into an agreement as required by CSL or otherwise commits any breach of the terms and conditions of the tender.

We, the bank, hereby irrevocably undertake to pay you any amount not exceeding in total the Guarantee Amount upon receipt by us of your demand in writing accompanied by the following documents:

Your signed statement certifying that the Contractor is in breach of his obligation(s) under the Contract and the respect in which the Contractor is in breach.

Any demand for payment should contain your authorized signatures which must be authorized by your bankers or by a notary public.

The guarantee shall remain in full force and effect during the period that would be taken for the finalization of the tender and till CSL certifies that the terms and conditions of the said tender have been fully and properly carried out by the said contractor and accordingly discharges this guarantee or for 6 months from the date of issue of this guarantee whichever is earlier. A notice of the claim under this guarantee may be served on the bank within 3 months after the said period in which case the same shall be enforceable.

We, the Bank, further agree that any change in the constitution of the said contractor or the said bank shall not discharge our liability hereunder. This guarantee shall not be avoided, released or affected by any variation in the terms of the tender, acceptance of the contract between the contractor and CSL or any neglect, indulgence or forbearance by CSL.

Notwithstanding anything contained herein:

1. Our liability under this Bank Guarantee shall not exceed -----only).
2. This Bank Guarantee shall be valid up to (date) (9 months from the date of issuing the BG ) and
3. We are liable to pay the guaranteed amount or any part thereof under this bank guarantee only and only if you serve upon us a written claim or demand on or before .....(validity date).

Any demand for payment under this Guarantee must be received by us at this office during working hours on or before the validity Date. Should we receive no claim from you by the validity Date, our liability to you will cease and the guarantee will definitely become null and void whether returned to us or not.

Yours truly,

Signature and seal of the  
guarantor:.....

Name of  
Bank:.....

Address: .....

Date:.....

**VENDOR DETAILS**

1	Name of the Bidder/Firm	
2	Registered office Address of Company/Firm	
3	Registered office Address of Company/Firm in Kolkata	
4	Telephone No./Fax No./Mobile No	
5	E-mail address	
6	Names of the contact person & designation	(i) (ii) (iii)
7	Type of Entity-Proprietorship/Partnership firm/Company/NSIC/MSME Category etc. (Please attach registration certificate of Firm/Partnership agreement/proprietorship documents)	
8	PAN Card Number	
	GST Registration Number (GST certificate to submitted along with the technical bid)	
	EPF registration no. (EPF registration certificate to be submitted along with the technical bid)  Note: In case firm does not have EPF registration reasons thereof to be indicated	
	ESI Registration No. (ESI registration certificate to be submitted along with the technical bid).  Note: In case firm does not have ESI registration reasons thereof to be indicated	
	Copy of License if applicable	
9	Whether the Agency has been blacklisted/debarred or given tender holiday or contract terminated before expiry of the contract period by any 'Govt./autonomous bodies/ organizations where bidder has provided services earlier due to deficiencies in service or misconduct etc.	Yes/No (please tick as applicable) If yes, please furnish details on a separate sheet

Sign &amp; seal of contractor: