



हुगली कोचीन शिपयार्ड लिमिटेड
(भारत सरकार का उद्यम)
HOOGHLY COCHIN SHIPYARD LIMITED
(A Govt. of India Enterprise)



वसुधैव कुटुम्बकम्
ONE EARTH • ONE FAMILY • ONE FUTURE

Tender No: HCSL/OPS/SB/TEN/2026/129

Dated 16.06.2026

NOTICE INVITING TENDER

Sealed competitive tenders are invited on behalf of Hooghly Cochin Shipyard Limited (HCSL) from experienced vendors for the under mentioned work, so as to reach the undersigned on or before the date and time mentioned below. Please refer Scope of Work, General Terms and Conditions and Special Terms attached.

Tender No. & date	HCSL/OPS/SB/TEN/2026/129 dated 16.06.2026
Name of work	Hiring Service of Scaffolding materials on rental basis and manpower for scaffolding works for 'Rubber Sealing Works of Box Caisson Gate' at M/s CKSRU Kolkata Netaji Subhas Dock (Detailed specification is enclosed separately)
Type of Tender	Two Bid (Email Mode) Price Bid Password Protected
Validity of Bid	90 days from the date of submission of tender
Cost of tender form	Nil
Earnest Money Deposit (EMD)	Nil
Last date & time of receipt of tender	23.06.2026 at 1600 Hrs.
Date & time of opening of technical bid	23.06.2026 at 1630 Hrs.
Tenure of contract	Positioning of Material/ Manpower within one week of PO. Duration: Period of 3 Months with a provision to extend for further period of 3 months (as per requirement).
Officer - in - Charge	For Tender: Name: Vijay Singh Designation: Manager (SC&C) Email: vijay.singh@hooghlycsl.com Mob. No: 86870 69271 For Technical: Name: Rakesh Sagar Designation: Manager (Design) Email: rakeshkr.sagar@hooghlycsl.com Mob. No. 95089 21575



Registered Office: Administrative Building, HCSL Premises, Satyen Bose Road,
P.O. Danesh Shaikh Lane, Nazirgunge, Howrah, West Bengal - 711 109.
☎ +91 (33)-2688 8282 ✉ contact@hooghlycsl.com 🌐 www.hooghlycsl.com

Shipyard: Nazirgunge Unit, Satyen Bose Road, P.O. Danesh SK Lane,
P.S. Sankrail, Howrah, West Bengal - 711109
☎ +91 (33)-2955 8283

CIN : U35900WB2017GOI223197, GSTIN : 19AAECH3640L1ZD

Tender to be submitted by email only. Tender reference should be clearly indicated on the subject of the Mail. Tenders should be submitted in two separate files as **PART-I "TECHNO-COMMERCIAL" & PART-II "PRICE" (Password Protected) indicating** the tender number, due date of the tender in the Mail and addressed to The Assistant General Manager (Material), Hooghly Cochin Shipyard Limited, Nazirgunge Unit, Howrah.

Tender to be submitted by E-mail only. No hard copy quotation of the bid will be accepted.

The tender documents can be downloaded from Hooghly-CSL Website www.hooghlycsl.com, CSL website www.cochinshipyard.in or <http://www.eprocure.gov.in>. The tender documents are available on above mentioned link. All corrigenda, addenda, amendments and clarifications to this tender will be hosted in the website www.hooghlycsl.com, www.cochinshipyard.in or <http://www.eprocure.gov.in> and not in the newspaper. Bidders shall keep themselves updated with all such developments till the last date and time of submission of tender.

Tender administration: Tender procedure/administration/evaluation including correspondences and awarding of contract will be done by M/s. Hooghly Cochin Shipyard Limited, Howrah, West Bengal.

For Hooghly Cochin Shipyard Limited

TABLE OF CONTENTS

Sl. No.	Description	Annexure
1	Scope of Work, Terms & Conditions and other requirements	1
2	Price Bid Format	2
3	Under Taking	3
4	General Terms & Conditions	4
5	Special Terms & Conditions	5
6	Commercial Checklist	6
7	Vendor details	7
8	NEFT Mandate Form	8
9	List of deviation	9
10	Form of Bank Guarantee towards EMD	10
11	Bank Guarantee in lieu of Security Deposit	11

Signature and Seal of the Bidder(s)

For Hooghly Cochin Shipyard Limited

ANNEXURE- 1

A. Scope of work

1. “Hiring Service of Scaffolding materials on rental basis and manpower for scaffolding works for Rubber Sealing Works of Box Caisson Gate at M/s CKSRU Kolkata Netaji Subhas Dock for Hooghly Cochin Shipyard Limited”.
2. Details of requirement given below:
3. Calculation for Approximate Volume 1700 m3.

Sl. No	Item Name for Stagging Materials	Qty in Nos
1	Vertical (3000 mm)	760
2	Horizontal (2445 mm)	1140
3	Transom	1140
4	Monkey Ladder (3000 mm)	100
5	Stagging Board (2460 mm)	400
6	Adjustable Jack	50
7	Swivel Clamp (40 x40 mm)	100
8	Nut Bolt (As per the requirement size)	100 Kg

Drawing attached – Wedge Type Stagging Material.

Sl. No.	Manpower Details	Qty (A)	Unit
1	Supervisors (Semiskilled)	1	No's
2	Scaffolder Workers (Unskilled)	4	No's

Part-B (Manpower required for scaffolding staging & erection works given below)

4. This materials & manpower will be required for Box Caisson Gate Rubber Sealing works at CKSRU.
5. All types of Scaffolding Materials, required tools & tackles, ladder, G.I wire, safety belt etc. for Scaffolding staging work shall be vendor’s scope.
6. Transportation of all Scaffolding Materials at Cochin Kolkata Ship Repair Unit (CKSRU), Netaji Subhas Dock, Kolkata and HCSL Nazirgunge are in vendor’s scope
7. Vendor needs to deliver all the materials as per Part-A after getting work order from HCSL.
8. All transportation is in vendor’s scope.
9. Staging work will be done as per site requirement and as per instruction by HCSL Officer in charge.
10. Vendor should maintain daily attendance register for engaged manpower & it should be approved by HCSL Officer in charge.

11. **Methodology of Hiring**

- i. Hiring service of Scaffolding materials with manpower initially for a period of 3 Months with a provision to extend for further period of 3 months (as per requirement) at the same rate terms and conditions on mutual agreement basis for caisson gate work at CKSRU.
- ii. The service of scaffolding materials with manpowershould is available for use on all days except National Holidays and other closed holidays of HCSL / CKSRU. An approximate usage of 26days in a month is estimated.
- iii. Normal working hours shall be 09 hours per day from 08:30 hrs to 17:30 hrs including lunch break however the timing may vary depending upon site requirements and the crane may be required at any time of the day.
- iv. For manpower, In case of usage beyond normal working hours and on holidays, fixed overtime rates will be applicable for the duration of use in hours. Overtime charges per hour shall be calculated as per quoted rate and will be paid at actuals on pro rata basis.
- v. If the project requirement is not there and production intends to release the scaffolding services, in that case the 7 days notice period will be given and payment upto last day of engagement on Mandays basis will be made.

B. Terms and Conditions

- 1) All Manpower's should be available throughout the shift at the site.
- 2) Working hour shall be 09 hours per day from 0830hrs to 1730 hrs including one-hour lunch break however timing may vary depending upon site requirements.
- 3) If Manpower is required to be used on Sundays, National Holidays, other holidays of HCSL and beyond normal working hours then overtime will be applicable for the duration of use in hours. It should be ensured by HCSL Officer in charge.
- 4) All Manpower should work as per the instructions from the HCSL officer in charge.
- 5) All Manpower should ensure the safety of others inside the yard, no damages to property and follow the SOP in connection with operation as per HCSL/CKSRU norms.
- 6) Food, accommodation and other facilities for the All Manpower shall be vendor's scope.
- 7) The Firm should not subcontract the work or part of the work to any other agency, if awarded the contract. An undertaking to be submitted along with the technical bid, as per annexure 3.
- 8) All Manpower are required to produce a valid police clearance certificate to avail gate passes.
- 9) All types of Scaffolding Materials, required tools & tackles, ladder, G.I wire, safety belt etc. for Scaffolding staging work shall be vendor's scope.
- 10) Transportation of all Scaffolding Materials at Cochin Kolkata Ship Repair Unit (CKSRU)., Netaji Subhas Dock, Kolkata are in vendor's scope.
- 11) Contractor should follow all safety rules in line with CKSRU & HCSL.
- 12) All Contractors working person must wear PPE.
- 13) ESI/PF document for all contractors working person should be submit at HCSL office.

14) All gate passes for Man and Material like port clearance, KOPT gate pass etc. contractor scope.

C. Entry and Exit of Personnel

1. Entry/exit passes for Materials and Manpower to work inside M/s CKSRU Netaji Subhas Dock shall be arranged by the agency after completing necessary formalities without any additional cost.
2. Vendor should require producing a valid police clearance certificate to avail gate passes for all Manpower to entering CKSRU and HCSL premises.

D. Safety rules

1. The firm shall ensure that the personnel employed by them are working in complete compliance with CKSRU/HCSL HSE rules. All personnel deployed at site shall wear PPE at all times when working within the factory premises of CKSRU. PPE is to be provided by the contractor/firm including, coverall, safety shoes, safety helmet, gloves, safety glasses, full body harness etc. The firm/contractor shall be entirely responsible for the safety of all personnel employed by him on the work and should ensure that the personnel are adequately covered under insurance.
2. The firm shall be solely responsible for any consequence arising out of any loss, damage or accident caused to the personnel engaged by him on duty. Any labour issues with employees have to be settled by the contractor or firm them self. HCSL Will not have any responsibility for any issue between firm and the employees, for any injury or illness to firm's workmen/other personnel during execution of work. In this regard firm will have to fully indemnify HCSL against any claim made by his workmen/other personnel.
3. Additional safety provision: For the work carried out within dock area the contractor shall abide by all provisions of the dock workers (Safety, Health and Welfare) Regulation 1990 without causing any damage / accident in the work premises which will be ultimately causing loss to HCSL either directly or indirectly. The contractor has to take all the necessary safety measures to prevent any damage / accident at site during the execution of work.

E. Payment

1. 100 % payment monthly basis for AllScaffolding materials with Manpower's of Bill value with applicable taxes will be released against Original Invoice subject to the full satisfaction and acceptance of work by Officer -in-charge. Original tax invoice should contain GST number of both parties and submit in triplicate.
2. On the first day of every month the contractor will be raise and submit the original invoice for the preceding month based on the actual attendance of personnel. The contractor has to submit documentary evidence of fulfillment of all the applicable statutory obligations for the deputed personnel including salary register for processing the invoice. Service charges will also be paid on pro data rate basis.
3. Contractor shall indicate details such as PAN, GST. Required for processing payment. Payments will be made through NEFT/RTGS/Cheque mode and necessary details shall be furnished by the contractor. HCSL reserves the right for the deduction of taxes and duties as applicable from the bill or invoice.
4. Payment will be released once in a month and tentatively within 30 days from the date of submission of an error free bill duly certified by the authorized HCSL Officer in charge.
5. Following documents to be submitted along with the invoice payment.
 - a) Work completion certificate/attendance log book for the month duly certified by the officer in charge.
 - b) Documents related to remittance of ESI, EPF and payment of salary if necessary.
6. If the project requirement is not there and production intends to release the scaffolding services, in that case the 7 days notice period will be given and payment upto last day of engagement on Mandays basis will be made.

F. Deviation list

1. Deviations if any, in the offer submitted form that of the tender enquiry in any form should be clearly furnished in a separate document titled as "List of Deviation".

G. Statutory conditions and labour laws

1. The firm must comply with statutory requirements, ESI/EPF, and other labour laws/regulations in force and as amended from time to time by Govt. of India. The firm must abide by minimum wages act as governed by Govt. of India rules in force and as amended in future.

2. The firm shall observe and comply with the provisions of all labour and industrial laws and enactments and shall comply with implement the provisions of the Factories Act, 1948, 'Employee Provident Funds & Miscellaneous Provisions Act, 1952, Employees State Insurance Act, Payment of Gratuity Act, minimum Wages Act, Payment of Bonus Act, Contract Labour (Regulation and Abolition) Act and all other enactments as are applicable to them and their workmen employed.
3. All contract workmen, except those exempted under the respective Acts, shall necessarily be insured under the ESI scheme and be made members of the EPF scheme from the day of their engagement as contract workmen at HCSL. All such insured contract workmen should carry with them their ESI Identity Card for verification by the authorities will be permitted to work in the company.
4. The firm shall be solely responsible for the payment of wages, salaries and other legal dues of its personnel who are employed or deployed by it from time to time. The firm shall promptly pay all due salaries and wages to its personnel providing service and salary has to effect before 10th of every month preceding the wage month. HCSL reserves the right to ask the firm to submit satisfactory evidence of payment due, salaries etc. In any event, HCSL shall not be liable for any payments, dues, wages and salaries of the personnel employed by the firm.

H. Arbitration

(a) Any disputes arising during the period of the contract shall, in the first instance be settled by mutual discussions and negotiations.

(b) If any dispute, disagreement or question arising out of or relating to or in consequence of the contract, or to its fulfilment, or the validity of enforcement thereof, cannot be settled mutually or the settlement of which is not herein specifically provided for, then the dispute shall within thirty days from the date either party informs the other in writing that such disputes, disagreement exists, be referred to arbitration. The arbitrators shall be appointed and the arbitration proceedings shall be conducted in accordance with and subject to the Arbitration and Conciliation Act, 1996 (No. 26 of 1996) as amended from time to time and the decision of the Arbitrators shall be final and binding on the parties hereto. The arbitration will be done by a Board comprising one arbitrator nominated by each party, and a mutually agreed Umpire. Each party shall bear its own cost of preparing and presenting its case. The cost of arbitration shall be shared equally by the parties unless the award provides otherwise. Performance under this Contract shall however, continue during arbitration proceedings and no payment due or payable by the parties hereto shall be withheld unless any such payment is or forms a part of the subject matter of arbitration proceedings.

(c) Seat & Venue of Arbitration: The seat & venue of arbitration shall be at Kolkata.

(d) Language of Arbitration: The Language of arbitration shall be English. Governing Law: The contract shall be governed by Indian Law

(e) In case of disputes, the same will be subjected to the jurisdiction of courts at Kolkata, West Bengal.

I. Indemnity Clause

1. The firm shall indemnify HCSL and keep harmless against any or all claims, liabilities, damages, losses, costs, charges, expenses, proceedings and actions of any nature whatsoever made or instituted against HCSL directly or indirectly by reason of:
 - i. Any wrongful, incorrect, dishonest, criminal, fraudulent or negligent work, misfeasance, disregard of duties by personnel of the firm; and/or
 - ii. Any theft, robbery, fraud or wrongful act or omission by personnel of the firm.

J. Security Deposit

- i) The successful contractor shall remit a security deposit of 3% of the total order value (excluding taxes, duties) in the form of demand draft drawn in favor of Hooghly Cochin Shipyard Ltd towards the satisfactory performance of the contract, if an order is placed on them. Alternatively, a Bank Guarantee equivalent to above % of the total order value (excluding taxes, duties) as per HCSL format from an International Bank as per approved list of banks available in CSL website (for overseas Contractor) & Scheduled Indian banks for Indian Contractor is to be submitted, if an order is placed towards satisfactory performance of the contract.
- ii) Security Deposit will be returned one (01) month after expiry of the contract. No interest shall be payable on SD for the period of its pendency. In case the contractor fails to submit the SD / Performance Guarantee in time, deduction of amount will be made from the bills submitted. Submission of Performance Security is not necessary for a contract value upto Rupees 20 (twenty) lakh.

K. Contract validity

1. The contract shall be valid for a period of 03 months, extendable upto a further period of 03(Three) months on at the discretion of HCSL without any changes in rate, contract terms and conditions, as per requirement.

L. General Conditions

1. L1 shall be determined based on the lowest cost quoted per month for Scaffolding materials with manpower
2. Place of work – A) CSL-Kolkata Ship Repair Unit (CKSRU), located inside NSD, Syama Prasad Mookerjee Port (SMP), Kolkata, West Bengal – 700043.
3. The bidders are expected to familiarize themselves about situation, wages and benefits applicable to laborers, working hours etc. prior to quoting. The submission of a bid by bidder implies that he has made himself aware of all the above situation and conditions. Any subsequent claim on this account will not be entertained.
4. All relevant clauses of general conditions of contract prevalent in HCSL will be applicable to this contract also. HSE guidelines issued by HCSL from time to time shall be followed by the firm.
5. Dock entry permit: If the work is to be carried out inside the docks area, the contractor shall abide by all rules and regulations of the docks in force from time to time as applicable. The contractor is required to obtain required permit for their manpower/vehicle as applicable issued by competent authority to enter yard premises.
6. Corrections and additions if any in the rate quoted must be attested / duly signed by the bidder. In case of error in multiplication / addition in amount calculated, the rate quoted will be considered as correct and the amount will be calculated accordingly. Conditional rebates & discounts, incomplete/ambiguous offers are likely to be rejected.
7. The contractor shall be on a principal-to-principal basis and it will not create any employer, employee relationship between HCSL and the firm or its employees/personnel. This contract shall also not be deemed to create any partnership, joint venture or any association between HCSL and the firm.
8. The contractor or the employee engaged by the contractor are strictly banned from use of any kind of Narcotics drugs/Alcohol/smoking etc. inside CKSRU premises and any illegal activity by the work men should be reported to the Officer-in-charge without delay and the contractor shall remove such persons from Yard premises.
9. HCSL reserves the right to award the contract to one or more firms or may split the scope of work, depending upon the actual necessity, as deemed fit.
10. HCSL reserves the right to reject any or all the offers without assigning any reason whatsoever.
11. The rates agreed upon as per quotation remain firm and fixed and will not be changed till conclusion of contract including extended period, if any,

12. The acceptance of a tender will rest with HCSL Competent Authority who does not bind himself to accept the lowest tender and reserves the right to himself the authority to reject any or all of the tenders received without assigning any reason.
13. HCSL reserves the right to terminate the contract at short notice in case the firm's performance is found not satisfactory with regard to progress of work, quality, time factor, labour dispute with their workers, poor safety records and other violation of any contract conditions. No claim whatsoever will be entertained by HCSL on this account.
14. The bidder is expected and deemed to have read, understood and agreed to all instructions, forms, terms and specifications etc. in the tender document while bidding.
15. Failure to furnish all information required or False/ambiguous information or submission of bid not substantially responsive to the bidding documents in every respect will be at the Bidder's risk and may result in rejection of the bid.
16. All pages of the offer (including all supporting documents/attachment) should be signed by the authorized signatory of the bidder in acceptance of tender conditions. Scanned copy of the same may be attached in the bid. Unsigned and unstamped bids shall be summarily rejected.
17. If any alteration is made in the tender documents submitted by the bidder and if found out (be it at any stage of the tender processing and even after award of the contract), it will be viewed seriously and HCSL has the right to reject the offer if required.
18. Pre-qualification Criteria : Necessary documents and work orders, readiness of material to be submitted for verification / evaluation of bidder.

For Hooghly Cochin Shipyard Limited

PRICEBIDFORMAT Annexure – 2

Quotation for Rental Charges of Scaffolding Materials & Manpower for scaffolding works for Caisson Gate Works at CKSRU, Kolkata							
Ref. Tender No: HCSL/OPS/SB/TEN/2026/129 dated 16.06.2026							
Part -A (Scaffolding Materials on Rental basis) Calculation for Approximate Volume 1700 m3							
Sl. No.	Material Description	Unit	QTY	Unit Rental Charges per month	Rental Charges Per Month (Excluding GST)	GST Amount	Total Rental Charges per month (Including GST)
			A	B	C=A X B	D	E=C + D
1	Vertical (3000 mm)	Nos	760				
2	Horizontal (2445 mm)	Nos	1140				
3	Transom	Nos	1140				
4	Monkey Ladder (3000 mm)	Nos	100				
5	Stagging Board (2460 mm)	Nos	400				
6	Adjustable Jack	Nos	50				
7	Swivel Clamp (40 x40 mm)	Nos	100				
8	Nut Bolt (As per the requirement size)	Nos	100 Kg				
Total Amount without GST (INR)							
Total GST Amount (INR)							
Total Amount with GST (INR)							

Part -B (Manpower for Scaffolding works)									
Sl. No.	Item Description	Unit	QTY	Unit Rate / month	Total amount per Month Excluding GST	Unit Rate of Extra work / hour (INR)	Total Extra work amount for 30 hrs/month (E=30*A*D)	Total GST Amount	Total Amount including GST per month
			A	B	C=A*B	D	E=30*A*D	F=(C+E) *18%	(G=C+E+F)
1	Supervisors (Semiskilled)	No's	1						
2	Scaffolder Workers (Unskilled)	No's	4						
Total Amount without GST									
Total Amount with GST (18%)									
Total Amount with GST (INR)									
Combined cost for [Part -A (Scaffolding Materials) and Part -B (Manpower)] excluding GST for One Month									
Combined cost for [Part -A (Scaffolding Materials) and Part -B (Manpower)] excluding GST for Three Month									

- Bidder has to submit the price bid as mentioned in the format only, otherwise bid will be rejected.
- L1 will be decided based on combined cost of Part-A & Part -B as mentioned in price bid format excluding GST.
- All line items need to be quoted in same format otherwise bid will be rejected.
- Quoted line items including transportation charges of materials, insurance & other charges.
- Scope of work, Tender terms & conditions and other requirements are same as mentioned in tender documents.

Sign & seal of Bidders

UNDER TAKING

I, Shri in my capacity as Managing Partner/Chairman & Managing Director / Proprietor of M/s..... do hereby give an undertaking that we shall not subcontract the work or part of work to any other agency if awarded the contract by HCSL (Kolkata).

Signature of firm or authorized personnel:

Name of authorized personnel:

Designation:

Address:

Contract No:

Annexure - 4

GENERAL TERMS AND CONDITIONS

1. Tenderers are to carefully go through the terms and conditions and the technical specification of the items for which offers are called for.
2. Offers are to be furnished in duplicate and should be free from overwriting. Corrections and additions, if any, must be attested. Incomplete/ambiguous offers are likely to be rejected.
3. Offer shall be submitted by Email (Two Bid, Price bid Password Protected) in the prescribed format to M/s Hooghly Cochin Shipyard Ltd (HCSL), Nazirgunge Works, Satyen Bose Road, P. O. Danesh Sk. Lane, Howrah - 711 109, West Bengal.
4. All applicable taxes, duties, transportation, delivery, etc at CKSRU Kolkata, should be included in the rate quoted, unless specified otherwise. HCSL reserves the right for the deduction of taxes and duties as applicable from the bill or invoice.
5. Indigenous Tenderers should quote prices for delivery of materials at CKSRU store. Insurance for transit shall be arranged by the vendor.
6. Bidders to note that no advance payment will be made by HCSL against work order issued.
7. Bidders can contact Officer-in-charge of the work which is indicated in the Tender Notice for any clarification before submitting the offer. If clarifications/details are not obtained before the offer is submitted, no claim on this account will be admitted.
8. **Force Majeure condition:** - Should failure in performance of the contract or part thereof arise from war insurrection, restraint imposed by Government, Act of Legislature or other Statutory Authority or illegal strike, riot, legal lock-out, flood, fire, explosion, act of God or any inevitable or unforeseen event beyond human control which may be construed as reasonable ground for an extension of time, HCSL may allow such additional time as is mutually agreed, to be justified by the circumstances of the case. The occurrence/cessation of force majeure situation is to be informed with documentary evidence within 15 days from the date of occurrence/cessation.
9. **Liquidated Damage:** -In case of delay in supply of ordered materials beyond the stipulated delivery period, which is not attributable to HCSL, supplier is to pay Liquidated Damages (and not by way of penalty) a sum equivalent to ½% (half percent) per week or part of the week of the total basic price in case of Machinery/Equipment and of basic price of materials delayed in all other cases, subject to a maximum of 10% of the total basic price of undelivered material/10% of total basic price of machinery/equipment (Total basic price is the order value excluding freight, taxes, other charges etc.). Further GST will be applicable upon LD and the same also will be deducted along with LD. However, LD applicability is without prejudice to HCSL right to terminate contract for delayed delivery or other actions as per Risk Purchase clause.
10. **Risk Purchase:**

If the contractor fails to commence the work in time, as per the terms in work order or violate any other terms & conditions of work order or If the firm's performance is found not satisfactory with regard to the progress of work, quality, and time factor, labour dispute with their workers, poor safety record, HCSL shall have the following rights:

 - a. To cancel the order partially or full with 15 days notice and to forfeit the security deposit, if any.
 - b. To impose tender holiday for the vendor for an appropriate period as decided by HCSL.
 - c. Risk Purchase

To initiate work completion from alternate source at the risk and cost of the contractor. This Risk Purchase clause is applicable only in the case of total order/ contract value (excluding taxes and duties) is Rs.20 lakhs and

above (or equivalent foreign currency). Cases of value less than 20 lakhs will be addressed by serving appropriate caution/ warning notice to the firm.

11. Suppliers are allowed to depute their authorized representative to be present at the time of opening of the price bid.
12. **Indian Agent** - Hooghly Cochin Shipyard Ltd. (HCSL) is a 100-percentage subsidiary of Cochin Shipyard Ltd (CSL) under ministry of shipping, Govt. of India Enterprise and prefers to deal directly with the supplier. However, if the supplier appoints an Indian Agent to deal with HCSL, the commission payable by the supplier to such an agency shall be intimated. The Indian agent shall be enlisted with Director General of Supplies and Disposals under the compulsory registration scheme of Ministry of Finance. "If manufacturer's effect supplied through Agents only, authorization in writing from manufacturers in favor of the Agent for supply to HCSL shall be furnished. If Indian Agent submits offers on behalf of foreign manufacturers, copy of the Agency Agreement between them and their mutual interest in the basis to be furnished. In case where an Agent participates in a tender on behalf of a foreign manufacturer Indian agent should submit specific authorization from the authorized person of foreign manufacturer, he should not quote on behalf of another foreign manufacturer along with the first manufacturer in a subsequent/parallel tender for the same item. In other words, one Agent cannot represent two suppliers or quote on their behalf in a particular tender.
13. **Jurisdiction:** All questions, disputes or difference arising under, out of, or in connection with contracts shall be subjected to the exclusive jurisdiction of the Courts at Kolkata, India. Alternate dispute resolution mechanism can also consider.
14. **Cost of Tender and EMD (Earnest Money Deposit):** Nil
15. **Guarantee: NIL**
16. Supplier should depute only persons who are entitled for exemption for income tax in India or any site work. In case the supplier does not depute such persons, the tax liability will be to supplier's account.
17. After submission of tender, no unsolicited correspondence will be entertained.
18. Hooghly Cochin Shipyard Limited does not bind itself to accept the lowest or any tender but reserves to itself the right to reject any or all or a part of any tender at its discretion.
19. In any case of the above conditions is not acceptable to the tenderer, it should be specifically indicated in the tender failing which it will be presumed that all the terms and conditions are acceptable.

For Hooghly Cochin Shipyard Limited

SPECIAL INSTRUCTIONS FOR SINGLE BID SYSTEM

1. MODE OF SUBMISSION OF TENDERS

Tenders should be submitted in two separate files as **PART-I"TECHNO-COMMERCIAL" & PART-II "PRICE" (Password Protected)** indicating the tender number, due date of the tender in the subject of the Mail and addressed to The Assistant General Manager (Materials).

2. TECHNO-COMMERCIAL PART SHOULD CONTAIN FOLLOWING DETAILS

- a. Stamped and signed copy of all pages of **tender document and corrigendum (if any)** with all supporting document.
- b. Technical Specification as per **Annexure .to** be complied
- c. Submission of Un-priced Bid as per Annexure along with Technical Bid.
- d. Techno-commercial check list as per **Annexure** with supporting documents if required.
- e. Vendor Details as per **Annexure.**
- f. NEFT mandate Form as per **Annexure .**
- g. List of Deviation (if Any) as per **Annexure .**
- h. Supplier should be in the business of Scaffolding Materials with Manpower Supply or Manpower Assistant (Fitter, Rigger & Helper) and supporting documents to be submitted along with the technical bid.

3. IMPORTANT INSTRUCTION

Suppliers shall take notice on the following points for its strict compliance

As the items are critically required, non-compliance of any of the following points will invite disqualification of the submitted offer without any further communication/ notice from this office in this regard.

- I. For the consideration of the offer and its price bid opening, suppliers should ensure the compliance of following points (which are mandatory in line with this particular tender) as stipulated in the general terms and conditions of enquiry and techno-commercial check list herewith.
 1. Payment of Tender fee
 2. EMD/ Bid Security Declaration
 3. Liquidated damage
 4. Payment terms
 5. Validity of offer
 6. Security deposit
 7. Guarantee
 8. **Service of Scaffolding Materials with Manpower as per work scope & terms and conditions**
 9. Risk purchase
 10. All Statutory documents, validity certificate of crane & lifting equipment's and ESI/EPF documents of all working persons of contractor
 11. Self-certified copy of MSE/NSIC certificate **in relevant** field, if applicable
 12. Price bid to be submitted in the price bid format attached at annexure-2

II. MSME/NSIC BENEFITS:

A. The following benefits are extended for all the firms who are registered with District Industries Center and come under the category of **Micro and Small** Enterprises holding a valid Entrepreneurs Memorandum (EM) part ii certificate or Udyog Aadhaar Certificate. However, in order to avail the benefits as per public procurement policy for MSME's orders, 2012, all MSE bidders are required to declare their Udyog Aadhaar Memorandum (UAM) number in Central Public Procurement Portal (CPPP) compulsorily.

- Tender Forms Shall Be Issued Free of Cost.
- Payment of earnest money deposit (EMD) is exempted.
- The list of items published as part of MSME order dated 23rd March 2012 {currently 358 items} shall be procured exclusively from MSE firms only.

B. For all firms who are registered with National Small Industries Corporation (NSIC) and come under Micro and Small Enterprises holding a valid NSIC certificate. The below benefit also extended in addition to above. Waiver of security deposit (SD) for the performance of the contract (5% of the order value by the way of bank guarantee till the supplies are completed), up to financial limit as mentioned in NSIC certificate. However, to ensure performance of the item during the guarantee period a performance bank guarantee (PBG) (3% of order value by the way of bank guarantee) to be submitted by the firm as applicable.

C. This tender shall be based on MSME order dated 23rd march 2012, pertaining to public procurement policy.

D. When supply/service as per tender is divisible in nature, MSE's within price band of L1+15 percent shall be allowed to supply a portion up to 20% of requirement by bringing down their price to L1 price where L1 is non MSE's. If multiple vendors satisfy the above condition, requirement shall be divided equally. In this scenario, preference shall be given to SC/ST vendors to such an extent that they are allowed to supply minimum 4% out of the 20% in line with the aforementioned MSME order. SC/ST vendors shall submit a valid certificate from district industries center / NSIC, for qualifying in the above criteria.

E. In the case of tender item non-splitable or non-divisible, MSE's quoting price band L1 + 15% (in the ascending order) may be awarded full/ complete supply of total tendered value to MSE's, considering spirit of policy for enhancing the government procurement from MSE's

III. It is reiterated that offers submitted without compliance of any one of the aforesaid points will not be considered for its evaluation and summarily be rejected on commercial background without any further clarification/ notice/ communication in this regard from M/S Hooghly Cochin Shipyard Ltd., even though the offer is technically acceptable.

4. **PRICE PART**

In Price Part as per Price Bid format (**Annexure**) should be signed and stamped kept in separate cover and submitted strictly as per tender schedule.

5. **Validity:** The offer should be valid for a minimum period of 90 Days of date of Technical Bid opening.
6. HCSL reserves the right to alter, modify the scope of supply at their discretion.
7. The Tenderer shall ensure that their Indian Agent is not representing any other suppliers for the same Tender. In other words, Indian Agents are not permitted to represent more than one firm for a particular Tender.
8. Details of optional items, if any, should be indicated under separate heading in the technical bid and the respective price details should be given in the price bid.
9. After submission of quotation / price opening, no unsolicited correspondence will be entertained.
10. Clarifications, either technical or commercial, should be submitted to points specially asked for only. The opportunity so given should not be used for correcting/changing/amending the data/conditions already submitted with the tender.
11. Price part should be submitted exactly in the Price Format as provided. Price should be quoted separately for each item shown in the format. Combining of figures against more than one item and ambiguous clauses will lead to rejection of the bid.
12. Check lists, technical& commercial, duly filled & signed should be submitted along with Part-I "Techno-Commercial" bid. Non-receipt of this document may lead to rejection of the offer.
13. Offers should be clear and unambiguous. Incomplete/ambiguous offers are likely to be rejected.
14. The tender document to be submitted by the bidder in duly signed and sealed format.
15. Bid Submission shall include Amendment / corrigendum / response to pre bid query duly signed and accept (if any).

For Hooghly Cochin Shipyard Limited

TECHNO-COMMERCIAL CHECK LIST				
SL. NO.	DESCRIPTION	COMPLIANCE		REMARKS
		YES	NO	
1	Submission of Tender in two (2) parts – Techno-commercial & Price			
2	Delivery date confirmation to yards delivery schedule			
3	Validity of offer – 90 Days			
4	Payment Terms - confirm your offered mode of payment			
	Monthly basis / 100% of the amount will be released after the completion of work against the order as per the scope of work, technical specifications and terms and conditions to the full satisfaction and acceptance of HCSL Officer-in-charge and on furnishing bill in triplicate.			
5	The Prices offered should remain firm till the completion of delivery, in case the purchase order is placed with you.			
6	Delivery the Service of Scaffolding Materials with Manpower at CKSRU NS Dock for HCSL.			
7	Have you considered Taxes, duties, levies, packing & forwarding etc., if any, in the offer.			
8	Compliance with Pre-qualification criterion.			
9	L.D. payable as per relevant Clause in the General terms of enquiry.			
10	Disputes in connection with contract subject to jurisdiction of courts at Kolkata India.			
11	Termination of contract/Risk purchase as per relevant clause in the General terms of enquiry.			
12	You should furnish class approval certificate/paper or Original Material test Certificate.			
13	Confirm all other terms and conditions of enquiry are acceptable.			
14	MSME/NSIC, if yes document required along with technical bid, in relevant sector.			
15	Vendor details to be submitted as per Annexure 7			
16	Supplier should be in the business of Scaffolding Materials with Manpower Supply or Manpower Assistant (Fitter, Rigger & Helper) and supporting documents to be submitted along with the technical bid			
17	The Supplier has to agree to clause guarantee/ warranty			
18	Pre-qualification Criteria: Necessary documents and work orders, readiness of material to be submitted for verification / evaluation of bidder.			

VENDOR DETAILS (to be submitted along with TECHNICAL BID)

1	Name of Bidder/Firm	
2	Registered office Address of Company/firm in Kolkata/Howrah: Local office address at Kolkata/Howrah (if held):	
3	Telephone No./Fax No./Mobile No:	
4	E-mail address:	
5	Names of the contact person & Designation:	1) 2) 3)
6	Type of Entity- Proprietorship/Partnership firm/company/NSIC/MSME Category etc. (Please attach registration certificate of Firm/Partnership agreement/proprietorship documents)	
7	Cost of Tender Details (DD No. Name of Bank)	
8	EMD Details (DD No. Name of Bank)	
9	PAN Card Number (Self-attested copy of PAN card has to be Submitted)	
	GST Registration No. (Self-attested copy has to be Submitted)	
10	Whether the agency has been blacklisted/de barred or given tender holiday or contract terminated before expiry of the contract period by any govt. autonomous bodies/organizations where bidder has provided services earlier due to deficiencies in service or misconduct etc.	Yes/No (Please tick as applicable) If yes, please furnish details on a separate sheet

- **Certified that the above information is true to the best of our belief and information.**

Place:

Date:

Signature of Supplier/Authorized signature of firm/agency:

Name of Supplier or authorized signatory of firm/agency:

Designation:

We hereby declare that the particulars given above are correct and complete. If the transaction is delayed or lost because of incomplete or incorrect information, we would not hold the company responsible.

(.....)

Signature of Employee

Bank Certificate

We certify that _____ has an Account No. _____
with us and we confirm that the details given above are correct as per our records.

Date:

Place:

(.....)

Authorized official of Bank

Annexure - 9

COMPLIANCE STATEMENT- SPECIAL INSTRUCTIONS FOR TENDERERS AND TECHNICAL SPECIFICATION	PAGE 1 OF 1
--	--------------------

Tender Name: Hiring Service of Scaffolding materials on rental basis and manpower for scaffolding works for Rubber Sealing Works of Box Caisson Gate at M/s CKSRU Kolkata Netaji Subhas Dock for Hooghly Cochin Shipyard Limited.

TENDER NO: ----- DATE: -----

We hereby confirm and truly declare that our Offer / Bid No.datedis in full compliance with the documents issued against the Tender No. -----dated -----, except for the deviations listed below:

LIST OF DEVIATIONS (HCSL reserves the right to reject offers with deviations)

Sl. No.	Description / Tender Reference	Reasons for Deviation

Name of tenderer:

Date: _____ Name & Designation _____ Seal & Signature _____

(Company Seal)

Annexure - 10

Form of bank Guarantee towards EMD

(On stamp paper of value Rs. 200/-)

This deed of GURANTEE made on day ofTwo thousand Twenty Two between HCSL on the one part and (Name and address of the bank) of the other part is as follows: -

In consideration of the HCSL having allowed M/s..... (Hereinafter referred to as 'the Supplier') to submit Tender No..... to them without Earnest Money according to the conditions of such Tender Notification.

We..... (here enter the name of 'the Bank') a Company incorporated under theAct and having its registered office at(hereinafter referred to as 'the bank') undertake to pay to HCSL on demand at Kolkata the sum of money payable as Earnest Money in respect of the Tender No.....made by the Supplier, in case the Supplier withdraws the tender before the date of firmness stipulated or when the tender is accepted by or on behalf of the HCSL the Supplier makes default in furnishing the Security Deposit or in entering into an agreement as required by the HCSL or otherwise commits any breach of the terms and conditions of the tender.

We,Bank Guarantee to pay the amount due and payable under this guarantee without any demur merely on demand from the HCSL. Any such demand made on the Bank shall be conclusive as regards the amount due and payable by the Bank under this guarantee. The liability of the surety shall be restricted to Rs(Rs..... only)

This guarantee shall not be avoided, released or affected by any variation in the terms of the tender, acceptance or the contract between the Contractor and the HCSL or any neglect indulgence or forbearance by the HCSL.

This guarantee shall remain in full force and effect during the period that would be taken for the finalization of the tender and till the HCSL certifies that the terms and conditions of the said tender have been fully and properly carried out by the Supplier and accordingly discharges this guarantee or for Six Months from the date of issue of this guarantee whichever is earlier. A notice of the claim under this guarantee may be served on the Bank within Six Months after the said period in which case the same shall be enforceable against the Bank notwithstanding the fact that the same is enforced after the expiry of the said period.

The decision of the CEO, HCSL as to whether the occasion or the ground has arisen for the demand of the surety form Bank shall be final. The HCSL shall be at liberty to act as though the Bank were the principal debtor.

We, the said Bank lastly undertake not to revoke this guarantee during its currency except with the previous consent of the HCSL in writing and agree that any change in the constitution of the said contractor or the said Bank shall not discharge our liability hereunder.

In witness whereof we have hereunto set our hand and seal this day
.....of.....Two thousand and
.....

Place:

Date:

Annexure 11

Bank Guarantee In lieu of Security Deposit/Performance Guarantee

(On stamp paper of value Rs.200/-)

TO
HOOGHLY COCHIN SHIPYARD LIMITED
Nazirgunge,
Howrah, Pin-711109

WHEREAS(Name & Address of Supplier) (hereinafter called "**the Supplier**") has undertaken, in pursuance of Contract.....No.....
.....Dated:.....toexecute.....

.....(Name of Contract and brief description of works) (hereinafter called "**the Contract**").

AND WHEREAS it has been stipulated by **HOOGHLY COCHIN SHIPYARD LTD** (The Buyer - hereinafter called "**HCSL**") in the said contract that the Supplier shall furnish HCSL with a Bank Guarantee by a recognized bank for the sum specified therein as security for compliance with the Supplier's obligations in accordance with the Contract.

AND WHEREAS we have agreed to give the Supplier such a Bank Guarantee.

NOW THEREFORE we
(Name of the Bank) having its Head Office at

..... (Address of Head Office) and acting through its branch office at (Address of the executing branch)

(hereinafter called "the Bank") hereby affirm that we are the Guarantor and responsible to HCSL, on behalf of the Supplier up to a total of.....(amount of Guarantee).....(in

words), such sum being payable in the types and proportions of currencies in which the Contract Price is payable and we undertake to pay HCSL upon your first written demand and without cavil or argument, any sum or sums within the limits of (amount of guarantee) as aforesaid without HCSL needing to prove or to show grounds or reasons for HCSL's demand for the sum specified therein.

We, the Bank, hereby waive the necessity of HCSL demanding the said debt from the Supplier before presenting us with the demand.

We, the Bank, further agree that no change or addition to or other modification of the terms of the Contract or of the Works to be performed there under or of any of the Contract documents which may be made between HCSL and the Supplier shall in any way release us from any liability under this guarantee, and we hereby waive notice of any such change, addition or modification.

This guarantee shall be valid until 28 days from the date of expiry of the Defects liability Warranty period.

Notwithstanding anything contained herein:

1. Our liability under this Bank Guarantee shall not exceed Rs.....(Rupees..... only).
2. This Bank Guarantee shall be valid up to (date) and
3. We are liable to pay the guaranteed amount or any part thereof under this bank guarantee only and only if HCSL serve upon us a written claim or demand on or before(date).

Any claim shall be accompanied by a written statement stating:

1. that the principal is in breach of its obligation(s) under the underlying contract, and
2. the respect in which the principal is in breach.

Yours truly,

Signature and seal of the guarantor:.....

Name of Bank:.....

Address:

Date:.....

[\[1\]](#)An amount shall be inserted by the Guarantor, representing the percentage of the Contract Price specified in the Contract and denominated in Dollars / Indian Rupees.

Encl-1

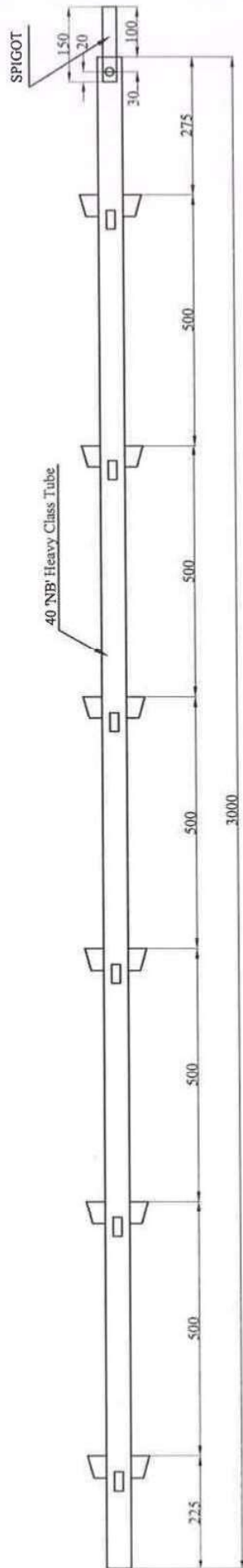

WEDGELOK STANDARD 3000 MM LONG

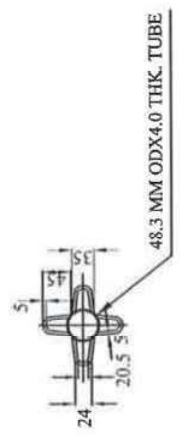

Encl-1

40 NB 'LIGHT' CLASS TUBE

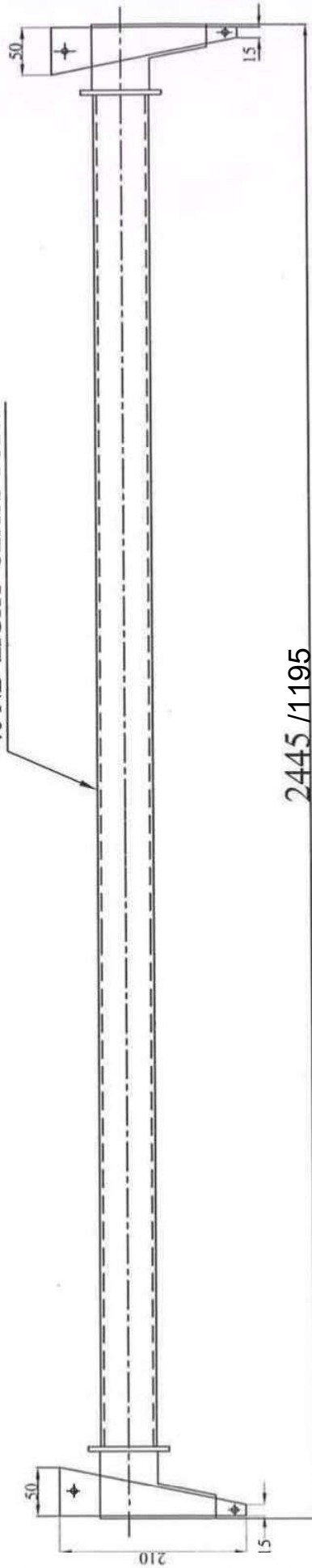

2445 / 1195

WEDGELOCK LEDGER

Encl-1

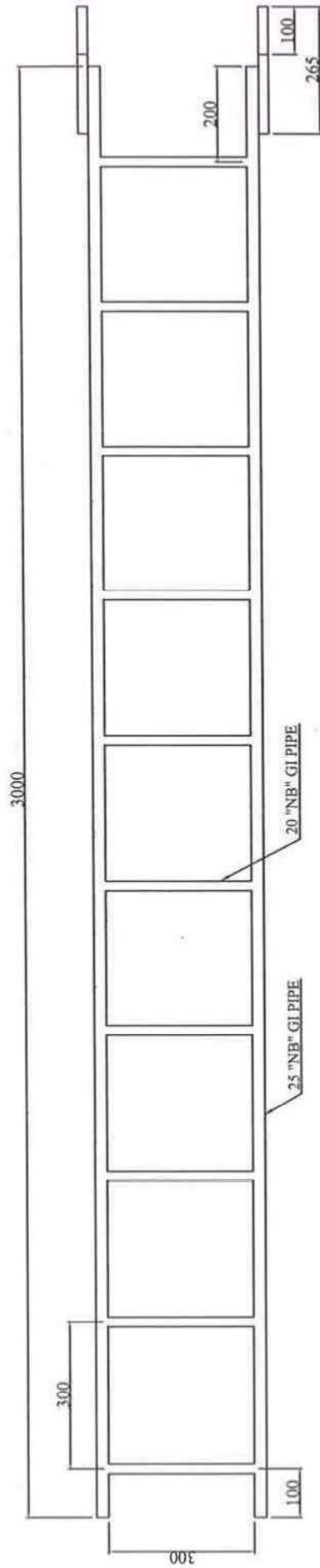
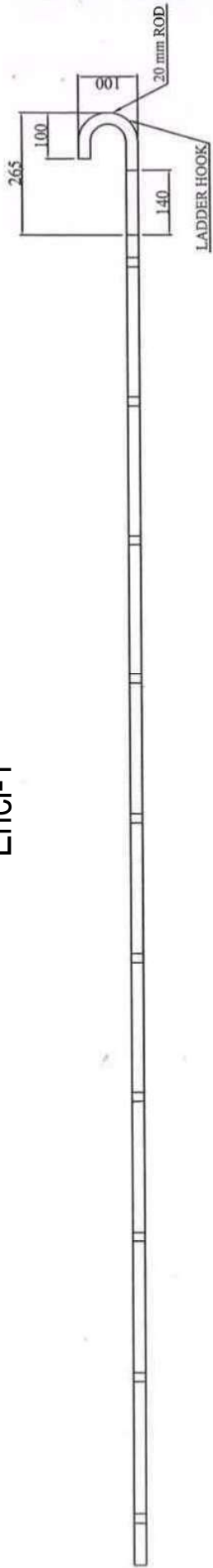

Encl-1

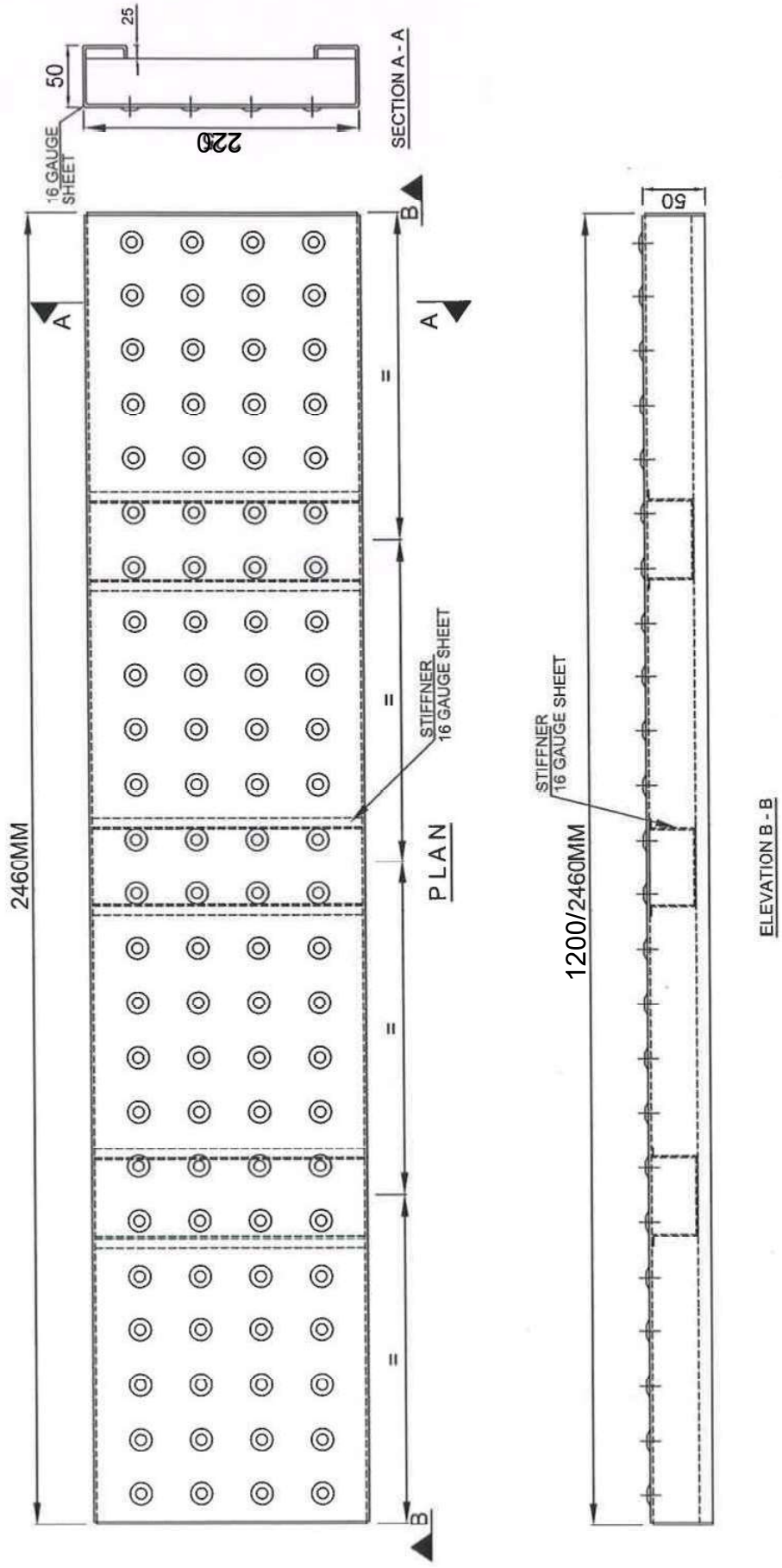

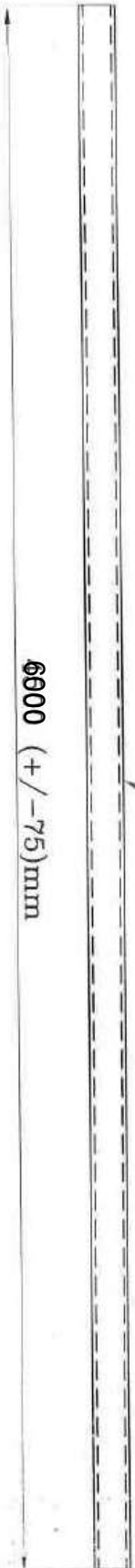

40 NB MEDIUM CLASS TUBE

6000 (+/- 75) mm

DIAGONAL BRACING TUBE

6000 (+/- 75mm)

Base Jack

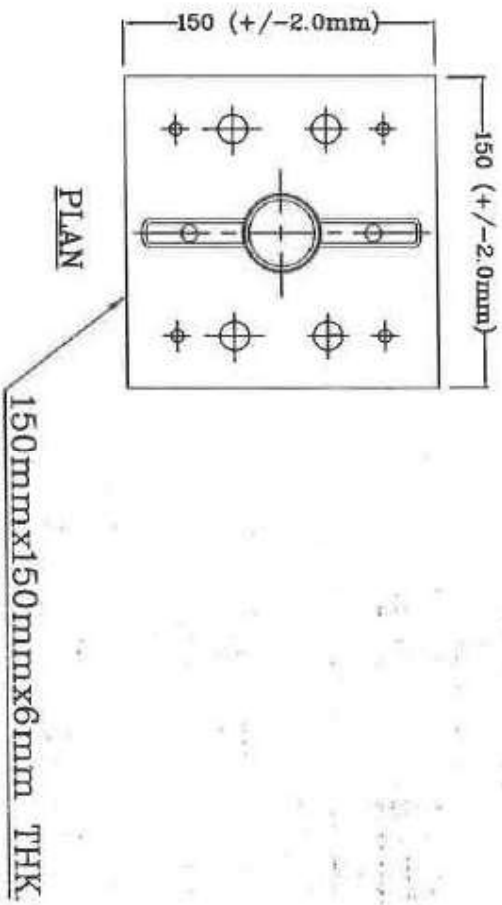
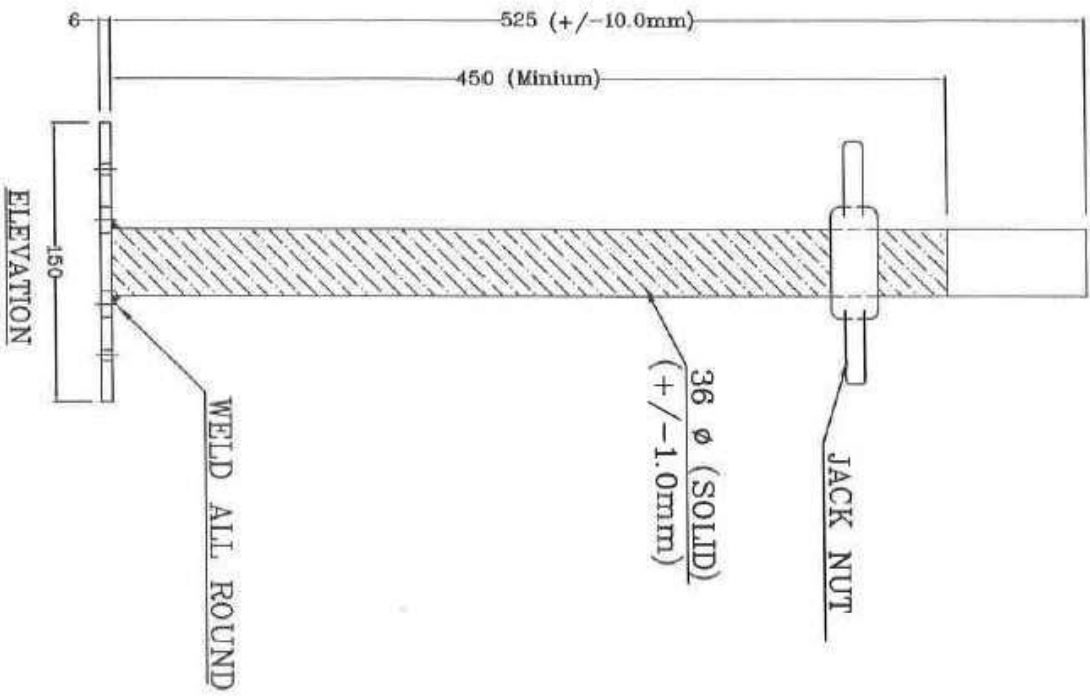

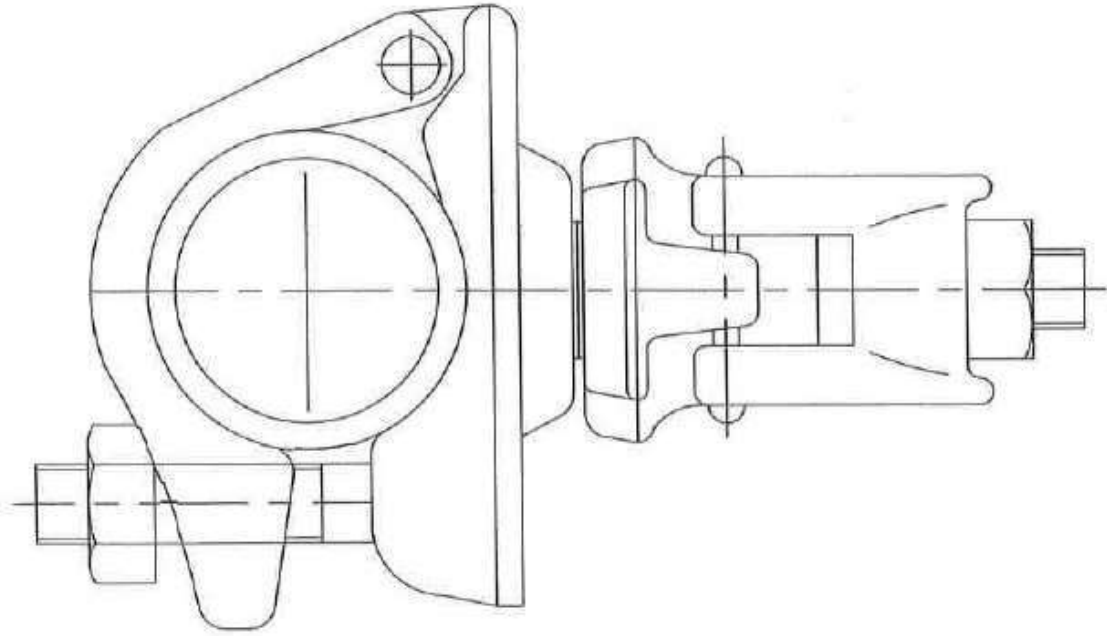

SWIVEL COUPLER (ELECTRO-PLATED)

40 x 40 mm. NB