



हुगली कोचीन शिपयार्ड लिमिटेड  
(भारत सरकार का उद्यम)  
**HOOGHLY COCHIN SHIPYARD LIMITED**  
(A Govt. of India Enterprise)



वसुधैव कुटुम्बकम्  
ONE EARTH • ONE FAMILY • ONE FUTURE

Dated: 03.12.2024

**CORRIGENDUM-1**

Ref. HCSL/PUR/TEN/2024/042, Dt. 19.11.2024.

Sub: Revised tender due date- Reg.

**TENDER FOR "Procurement of Tyre Fender with Accessories for Tugs at Hooghly Cochin Shipyard Limited, Nazirgunge Unit, Howrah".**

The Amendments are given below:

1. Last date of submission of tender is extended upto 10.12.2024 at 15:00 Hrs.
2. The date of opening of tender will be at 15:30 Hrs on 10.12.2024.

All other terms & conditions shall remain unaltered.

For Hooghly Cochin Shipyard Limited



Registered Office: Administrative Building, HCSL Premises, Satyen Bose Road,  
P.O. Danesh Shaikh Lane, Nazirgunge, Howrah, West Bengal - 711 109.  
☎ +91 (33)-2688 8282 ✉ contact@hooghlycsl.com 🌐 www.hooghlycsl.com

Shipyard: Nazirgunge Unit, Satyen Bose Road, P.O. Danesh SK Lane,  
P.S. Sanikrail, Howrah, West Bengal - 711109  
☎ +91 (33)-2955 8283

CIN : U35900WB2017GOI223197 GSTIN : 19AAECH3640L1ZD



हुगली कोचीन शिपयार्ड लिमिटेड  
(भारत सरकार का उद्यम)  
**HOOGHLY COCHIN SHIPYARD LIMITED**  
(A Govt. of India Enterprise)



वसुधैव कुटुम्बकम्  
ONE EARTH • ONE FAMILY • ONE FUTURE

Tender No: HCSL/PUR/TEN/2024/042

Dt. 19.11.2024

**TENDER NOTICE**

Offers are invited on behalf of Hooghly Cochin Shipyard Limited (HCSL) for the under mentioned work, so as to reach the undersigned on or before the date and time mentioned below. Please refer technical specification, General Terms and Conditions as attached.

Tender No. & date	HCSL/PUR/TEN/2024/042, Dt. 19.11.2024
Scope of Supply / Work	Procurement of Tyre Fender with Accessories for Tugs at Hooghly Cochin Shipyard Limited, Nazirgunge Unit, Howrah.
Type of Tender	<b>Two Bid</b>
Tender Fee & EMD	<b>Nil</b>
Last date & time of receipt of tender	<b>03.12.2024</b> at 1500 Hrs.
Date & time of opening of technical bid	<b>03.12.2024</b> at 1530 Hrs.
Delivery Period	The materials to be delivered as per following schedules: Tyre Fenders and its fittings – Tug 1 - 16th April, 2025 Tyre Fenders and its fittings – Tug 2 - 17th June, 2025 Tyre Fenders and its fittings – Tug 3 - 16th Aug, 2025 Tyre Fenders and its fittings – Tug 4 - 15th Sept, 2025
Officer - in - Charge	Name: Johnson Grandage Designation: Dy. Manager (Mechanical) Email: <a href="mailto:johnson.g@hooghlycsl.com">johnson.g@hooghlycsl.com</a> Phone No: +91 9562266770  Name: Girish Gupta Designation: Asst. Manager (Materials) Email: <a href="mailto:girish.gupta@hooghlycsl.com">girish.gupta@hooghlycsl.com</a> Phone No: +91 8085278430

**Tender to be submitted by Email only. Tender reference should be clearly indicated on the subject of the Mail.** Tenders should be submitted in two separate files as **PART-I "TECHNO-COMMERCIAL" & PART-II "PRICE" (Password Protected)** indicating the tender number, due date of the tender in the Mail and addressed to The Assistant General Manager (Material), Hooghly Cochin Shipyard Limited, Nazirgunge Unit, Howrah.



For Hooghly Cochin Shipyard Limited

Signature and Seal of the Bidder(s)



1. **Minimum qualification criteria for participating in the tender will be as follows:**

- i. Successful experience as material supplier in the successful completion of at least **one (1) similar material supply** of nature and complexity comparable to the proposed material within the last **5 years** from the date of issue of tender document. The value of the work should not be less than **Rs.10 lakhs**. (Satisfactory completion certificate from the Client for work done should be submitted along with bid).

Or

Successful experience as material supplier in the successful completion of at least **two (2) similar material supply** of nature and complexity comparable to the proposed material supply within the last **5 years** from the date of issue of tender document. The value of the work should not be less than **Rs.6.3 lakhs**. (Satisfactory completion certificate from the Client for work done should be submitted along with bid).

Or

Successful experience as material supplier in the successful completion of at least **three (3) similar material supply** of nature and complexity comparable to the proposed material supply within the last **5 years** from the date of issue of tender document. The value of the work should not be less than **Rs.5 lakhs**. (Satisfactory completion certificate from the Client for work done should be submitted along with bid).

**Similar Supply means: Supply of Used Aircraft tyres or Heavy Equipment Tyres for State/Central Govt., Shipyards, Heavy Engineering Industry within the respective years ending last day of month previous to one in which applications are invited.**

**Note:** The value of executed works shall be brought to current costing level by enhancing the actual value of works at simple rate of 7% per annum, calculated from the date of completion to the last date of submission of tender document. HCSL will convert all amounts stated in various currencies to equivalent Indian Rupees (INR) based on the exchange rate at the closing of corresponding financial year (31 March) authorized by State Bank of India.

- i. The average Annual Turnover of the bidder should be more than **Rs. 6.3 Lakhs** during the last three preceding years. (Audited Balance sheets showing turnover, Profit & Loss account of the firm for the preceding 03 years (2020-21, 2021-22, 2022-23) should be submitted along with the application for prequalification).
- ii. The Tenderer should enclose copy of PAN, GST registration certificate, Income tax returns for last three FY.

iii. Offers from joint ventures/consortium will not be accepted.

iv. Net worth of the bidder must be positive as per the latest balance sheet. (MSME/NSIC will get exemptions)

The tender documents can be downloaded from HCSL website [www.cochinshipyard.com](http://www.cochinshipyard.com). The tender documents are available on above mentioned link. All corrigenda, addenda, amendments and clarifications to this tender will be hosted in the website [www.cochinshipyard.com](http://www.cochinshipyard.com) or <http://www.eprocure.gov.in> and not in the newspaper. Bidders shall keep themselves updated with all such developments till the last date and time of submission of tender.

**Tender administration:** Tender procedure/administration/evaluation including correspondences and awarding of contract will be done M/s. Hooghly Cochin Shipyard Limited, Howrah, West Bengal.

**Tender administration:** Tender procedure/administration/evaluation including correspondences and awarding of contract will be done by M/s. Hooghly Cochin Shipyard Limited, Howrah, West Bengal.

Name: Johnson Grandage  
Designation: Dy. Manager (Mechanical)  
Email: [johnson.g@hooghlycsl.com](mailto:johnson.g@hooghlycsl.com)  
Phone No: +91 9562266770

Name: Girish Gupta  
Designation: Asst. Manager (Materials)  
Email: [girish.gupta@hooghlycsl.com](mailto:girish.gupta@hooghlycsl.com)  
Phone No: +91 8085278430

**For any technical queries:**

Name: Abhishek Kumar Mishra  
Designation: Naval Arch. (Design)  
Email: [abhishek.mishra@cochinshipyard.in](mailto:abhishek.mishra@cochinshipyard.in)  
Phone No: +91 7994210331



**For Hooghly Cochin Shipyard Limited**

*Johnson Grandage*  
Dy. Manager (Mech)  
Johnson Grandage

## TABLE OF CONTENTS

Sl. No.	Description	Annexure
1.	Scope of supply & instructions to bidders	Annexure-1
2.	Technical Specification & Dimensions of the offered product	Annexure-2A & 2B
3.	Price Bid Format	Annexure-3
4.	Instruction to bidders	Annexure-4
5.	General Terms & Conditions	Annexure-5
6.	Restriction of bidders sharing land border with India	Annexure-6
7.	Preference to Make in India	Annexure-7
8.	List of Deviations	Annexure-8
9.	SD/Bank Guarantee Format	Annexure-9

**For Hooghly Cochin  
Shipyards Limited**



Signature and Seal of the Bidder(s)

## ANNEXURE- 1

### **A) SCOPE OF SUPPLY**

Supply of Tyre Fender with Accessories for Hooghly Cochin Shipyard Limited, Nazirgunge Unit, Howrah (Detailed specification is enclosed separately in Annexure-2).

Note: (i) Details as per Annexure 2B to be submitted by vendor along with offer.

### **B) IMPORTANT INSTRUCTION**

*Suppliers shall take notice on the following points for its strict compliance*

As the items are critically required, non-compliance of any of the following points will invite disqualification of the submitted offer without any further communication/ notice from this office in this regard.

- I. For the consideration of the offer and its price bid opening, suppliers should ensure the compliance of following points (which are mandatory in line with this particular tender) as stipulated in the general terms and conditions of enquiry and techno-commercial check list herewith.

1. Pre-Qualification Criterion.
2. Payment of Tender fee.
3. EMD/ Bid Security Declaration.
4. Liquidated damage.
5. Payment terms.
6. Validity of offer.
7. Security deposit.
8. Guarantee.
9. **Material test certificates to meet the Specification. (for shackles & slings)**
10. Risk purchase
11. **Make and Model of offered item. (For tyres)**
12. Submission of relevant catalog for offered material (if applicable)
13. Self-certified copy of MSE/NSIC certificate **in relevant** field, if applicable
14. Price bid to be submitted strictly as per the price bid format attached at Annexure-3
15. Un priced bid as per Annexure-3 to be submitted along with techno commercial bid with details like percentage of taxes & duties applicable & details like quoted/nil/included to be mentioned for each line item

### **II. MSME/ NSIC BENEFITS:**

**A.** The following benefits are extended for all the firms who are registered with District Industries Center and come under the category of **Micro and Small** Enterprises holding a valid Entrepreneurs Memorandum (EM) part ii certificate or Udyog Aadhaar Certificate. However, in order to avail the benefits as per public procurement policy for MSME's orders, 2012, all MSE bidders are required to declare their Udyog Aadhaar Memorandum (UAM) number in Central Public Procurement Portal (CPPP) compulsorily.

- Tender Forms Shall Be Issued Free of Cost.

- Payment of earnest money deposit (EMD) is exempted.
- The list of items published as part of MSME order dated 23rd March 2012 {currently 358 items} shall be procured exclusively from MSE firms only.

**B.** For all firms who are registered with National Small Industries Corporation (NSIC) and come under Micro and Small Enterprises holding a valid NSIC certificate, the below benefit also extended in addition to above.

Waiver of security deposit (SD) for the performance of the contract (3% of the order value by the way of bank guarantee till the supplies are completed), up to financial limit as mentioned in NSIC certificate. However, to ensure performance of the item during the guarantee period a performance bank guarantee (PBG) (5% of order value by the way of bank guarantee) to be submitted by the firm as applicable.

**C.** This tender shall be based on MSME order dated 23rd march 2012, pertaining to public procurement policy.

**D.** When supply/service as per tender is divisible in nature, MSE's within price band of L1+15 percent shall be allowed to supply a portion up to 20% of requirement by bringing down their price to L1 price where L1 is non MSE's. If multiple vendors satisfy the above condition, requirement shall be divided equally. In this scenario, preference shall be given to SC/ST vendors to such an extent that they are allowed to supply minimum 4% out of the 20% in line with the aforementioned MSME order. SC/ST vendors shall submit a valid certificate from district industries center / NSIC, for qualifying in the above criteria.

**E.** In the case of tender item non-splitable or non-divisible, MSE's quoting price band L1 + 15% (in the ascending order) may be awarded full/ complete supply of total tendered value to MSE's, considering spirit of policy for enhancing the government procurement from MSE's



**For Hooghly Cochin Shipyard Limited**

*Handwritten signature: J Johnson*  
*Handwritten text: J Johnson*

Rev. No.	Pages	Description	Date	Sign.
0	6	FIRST ISSUE	07-11-2024	Rakesh
1	6	Modifications as per Review Comments	08-11-2024	Rakesh

**This Document Contains 8 Pages**



**HOOGHLY COCHIN SHIPYARD LIMITED  
HOWRAH – 711 109**

<b>YARD NO</b>	<b>01124001, 01224002, 01324003, 01424004</b>	<b>PROJECT: 40 T BOLLARD PULL ASD TUG</b>
<b>OWNER</b>	INDUSTRIAL HANDLING PRIVATE LIMITED	<b>PURCHASE TECHNICAL SPECIFICATION FOR SUPPLY OF TYRE FENDERS WITH ACCESSORIES</b>
<b>APPROVED</b>	RAKESH KR. SAGAR	
<b>CHECKED</b>	MANI KR. PN.	
<b>PREPARED</b>	A.K.MISHRA	
<b>DATE</b>	08-11-2024	<b>Document No:- PTS-01124001-030</b>
<b>ISSUED TO</b>	<b>NO. DEP.</b>	
	<b>NO.</b>	

This document/specification is the property of Hooghly Cochin Shipyard Limited, and it must not be copied or the contents thereof or any information received in conjunction therewith must not be imparted /shared to any third party or utilized for any other purpose. The receipt of the document/specification implies that the conditions as mentioned herein are accepted.



**Table of Contents**

**1 TECHNICAL SPECIFICATIONS FOR TYRE FENDERS ..... 1**  
**2 TECHNICAL SPECIFICATIONS FOR ANCHOR SHACKLE & SLINGS ..... 2**

## SECTION A – TECHNICAL SPECIFICATION FOR TYRE FENDERS

### 1. SCOPE OF SUPPLY

This specification relates to the supply of Tire Fenders for the 40T Bollard Pull ASD Tug being built at Hooghly Cochin Shipyard Ltd. Quantity requirement refer to table at Sl. No. 2.

### 2. Quantity

The Below mentioned table represents requirement for 1 Sip. The Total Requirement is for 4 Ships.

S.No.	Tyre Type	Size	Qty. per Ship	Qty for 4 Ships	Comments
1.	Heavy Duty Aircraft Tyres	Ø864 OD	20	80	Drawing Attached
2.	Heavy Equipment Tyres	Ø1350 OD	5	20	Drawing Attached

OD – Means Outside Diameter.  
Fendering Arrangement drawing attached for reference.  
Tire Fenders offered by the supplier shall be submitted with drawings for Evaluation & Subject to yard/owner approval.

### 3. CONDITIONS OF SUPPLY

- 1.1 The items shall be of best quality material and workmanship to be supplied. The supply shall be as per the attached sample drawings and deviations if any shall be clearly indicated in the offer.
- 1.2 The tire fender shall be of unexploited and of good Quality suited for 40T bollard pull operation. Also, the items shall be equipped for efficient and proper working under worst marine conditions.
- 1.3 Anything necessary to accomplish this must be supplied notwithstanding any omission in the specification.

### 4. TESTING AND INSPECTION

- 1.1 Manufacturer's shop test and inspection shall be carried out in accordance with the manufacturer's standard and certificates shall be submitted.
- 1.2 Visual Inspection of the Tyres shall be carried by the QC Dept. of HCSL after delivery & acceptance is subject to the satisfaction of the QC Personnel.

### 5. GUARANTEE

As per the commercial terms and conditions of this tender enquiry.

\*\*\*\*\*

## **SECTION B – TECHNICAL SPECIFICATION FOR ANCHOR SHACKLE AND SLING**

### **1. SCOPE OF SUPPLY**

This specification relates to the supply of Anchor Shackle and Sling for Tire Fenders for the 40T Bollard Pull ASD Tug being built at Hooghly Cochin Shipyard Ltd. Quantity requirement refer to table at Sl. No. 2.

### **2. Quantity**

The quantity indicated below is for 01 vessel. The total requirement is for 04 vessels. The supply shall be as per Annexure 1 of this document.

<b>S.No.</b>	<b>Item Type</b>	<b>Qty. per Ship</b>	<b>Qty. for 4 Ships</b>	<b>Comments</b>
1.	19.1mm SS 316 L Anchor Shackle with SS Bolt, Nut & Pin Set	100 Nos. of Set (Inclusive of each item)	400 Nos. of Set (inclusive of each item)	Drawing Attached
2.	Nylon Sling SWL: 3T minimum – 4 Nos. for Heavy Duty Aircraft tire with OD Ø864	80 Nos.	320 nos.	Drawing Attached
3.	Nylon Sling SWL: 3T minimum – 4 Nos. for Heavy Equipment tire with OD Ø1350	20 Nos.	80 Nos.	Drawing Attached

OD – Means Outside Diameter.  
Fendering Arrangement drawing attached for reference.  
Sling shall be provided as mentioned above in table with reference to Anchor Shackle compatibility.

### **3. CONDITIONS OF SUPPLY**

- 1.3 The items shall be of best quality material and workmanship to be supplied. The supply shall be as per the attached sample drawings and deviations if any shall be clearly indicated in the offer.
- 1.4 The Anchor Shackle and Sling for Tire Fenders shall be of unexploited and of good Quality suited for 40T bollard pull operation. Also, the items shall be equipped for efficient and proper working under worst marine conditions.
- 1.5 Anything necessary to accomplish this must be supplied notwithstanding any omission in the specification.

### **4. TESTING AND INSPECTION**

Manufacturer's shop test and inspection shall be carried out in accordance with the manufacturer's standard and certificates shall be submitted.

### **5. GUARANTEE**

As per the commercial terms and conditions of this tender enquiry.

\*\*\*\*\*

**NOTES:**

1. REFER TO THE ROBERT ALLAN LTD. DRAWING AND CONTRACT SPECIFICATION PACKAGE IN ITS ENTIRETY. PARTICULAR ATTENTION SHOULD BE PAID TO THE FOLLOWING:
  - 10010 LINES PLAN
  - 21010 STRUCTURAL ARRANGEMENT
  - 21050 STRUCTURAL SECTIONS
  - 22210 BULWARKS STRUCTURE
  - 30000 GENERAL ARRANGEMENT
2. ALL FENDER DETAILS ARE TYPICAL – DETAILS AND DIMENSIONS ARE TO BE VERIFIED WITH SUPPLIER BASED UPON PURCHASED FENDERS.
3. GRIND SMOOTH ALL EDGES IN ACCORDANCE WITH SPECIFICATION. PARTICULAR ATTENTION TO BE PAID TO EDGES IN CONTACT WITH FENDERS IN WAY OF WEB SLINGS.
4. PAINT ALL STEELWORK BEHIND FENDERS BEFORE FINAL INSTALLATION OF FENDERING.
5. ALL FENDER RESTRAINT HARDWARE TO BE STAINLESS STEEL.
6. ALL SECURING HOLES FOR FENDER MOUNTING PINS TO BE PUNCHED OR DRILLED, NOT FLAME-CUT.
7. APPLY WELDING PROCEDURES, MATERIALS AND WORKMANSHIP IN ACCORDANCE WITH CLASS REQUIREMENTS AND APPROVED WELD SCHEDULE. APPLY DOUBLE CONTINUOUS WELD TO ALL CONNECTIONS OF FENDER ATTACHMENTS.
8. LUBRICATE ALL BOLT CONNECTIONS THOROUGHLY TO AVOID GALLING.

**ANNEXURE - 1**

**Page 3 of 6**

This document/specification is the property of Hooghly Cochin Shipyard Limited, and it must not be copied or the contents thereof or any information received in conjunction therewith must not be imparted /shared to any third party or utilized for any other purpose. The receipt of the Document / specification implies that the conditions as mentioned herein are accepted.

**ABBREVIATIONS:**

ABL	- ABOVE BASELINE	OCL	- OFF CENTRELINE
CL, C	- CENTRELINE	OD	- OUTSIDE DIAMETER
DWG.	- DRAWING	PL	- PLATE
DWL	- DESIGN WATERLINE	REF	- REFERENCE
FB	- FLAT BAR	S.S.	- STAINLESS STEEL
IWO	- IN WAY OF	SWL	- SAFE WORKING LOAD
MIN.	- MINIMUM	TYP.	- TYPICAL
OC	- ON CENTRE		



**ROBERT ALLAN**  
Naval Architects & Marine Engineers

Designed in Vancouver, Canada  
www.ral.ca

All information contained in or disclosed by this document is confidential and proprietary, and is the exclusive intellectual property of Robert Allan Ltd. This design information is reserved for the exclusive use of the client identified hereon. All further design, use, and sales rights attached thereto are exclusively reserved by Robert Allan Ltd., and any reproduction, communication or distribution of this information is prohibited without the prior written consent of Robert Allan Ltd. Absolutely no modifications or alterations to this document may be made by any party without the prior written consent of Robert Allan Ltd.

This document is for guidance only, indicating the key characteristics of the design's configuration, performance, materials, and standards of construction based on preliminary equipment selection. It is not intended to be the sole basis for construction. The builder, or any other party that uses or relies on or makes decisions based on this document, assumes full responsibility to complete detailed engineering design and finalize equipment selection to a point suitable for construction and implementation.

Engineers and Geoscientists BC Permit to Practice number 1001019

**CONTRACT DESIGN**

DESIGN	<b>RAmparts 2800 TUGBOAT</b>			
CLIENT	HOOGHLY COCHIN SHIPYARD LTD.			
TITLE	FENDERING ARRANGEMENT			
DRAWN BY	ENGINEER	PLOT SIZE	SHEET	
BC	DJH	ANSI B	1 OF 4	
PROJECT	DRAWING		REV.	
224-029	45000		1	

1	FIRST ISSUE	SEP. 12/24	BC	DJH	DJH
REV.	REVISIONS	DATE	DWN	CHK	APP.

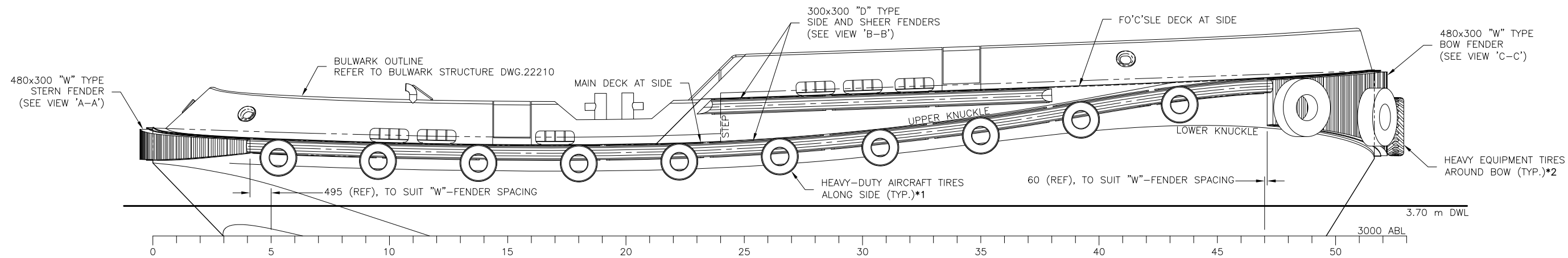

**OUTBOARD PROFILE**

STARBOARD SIDE SHOWN, LOOKING TO PORT  
PORT SIDE SIMILAR

\*1 34x10.75 (ø864 OD) TIRES SHOWN FOR REFERENCE.  
ADJUST TO SUIT SELECTED TIRE. VERIFY LOCATION  
TO SUIT OWNER PREFERENCE. SEE DETAIL 'D'

\*2 1400-24 (ø1350 OD) TIRES SHOWN FOR REFERENCE.  
ADJUST TO SUIT SELECTED TIRE. VERIFY LOCATION  
TO SUIT OWNER PREFERENCE. SEE DETAIL 'E'

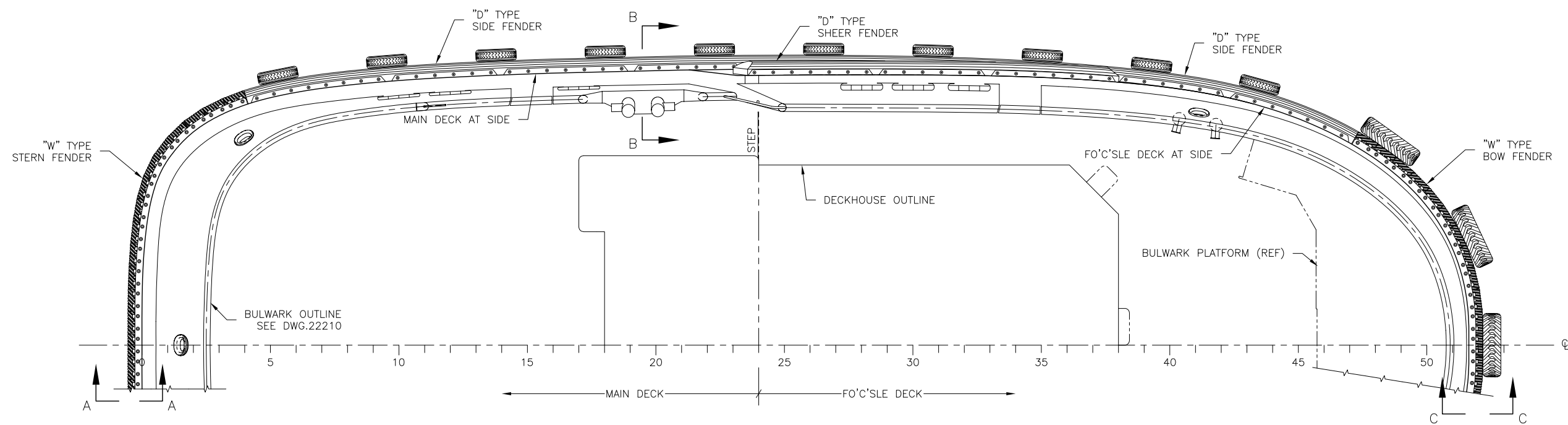

**DECK PLAN**

PORT SIDE SHOWN, STARBOARD SIDE SIMILAR

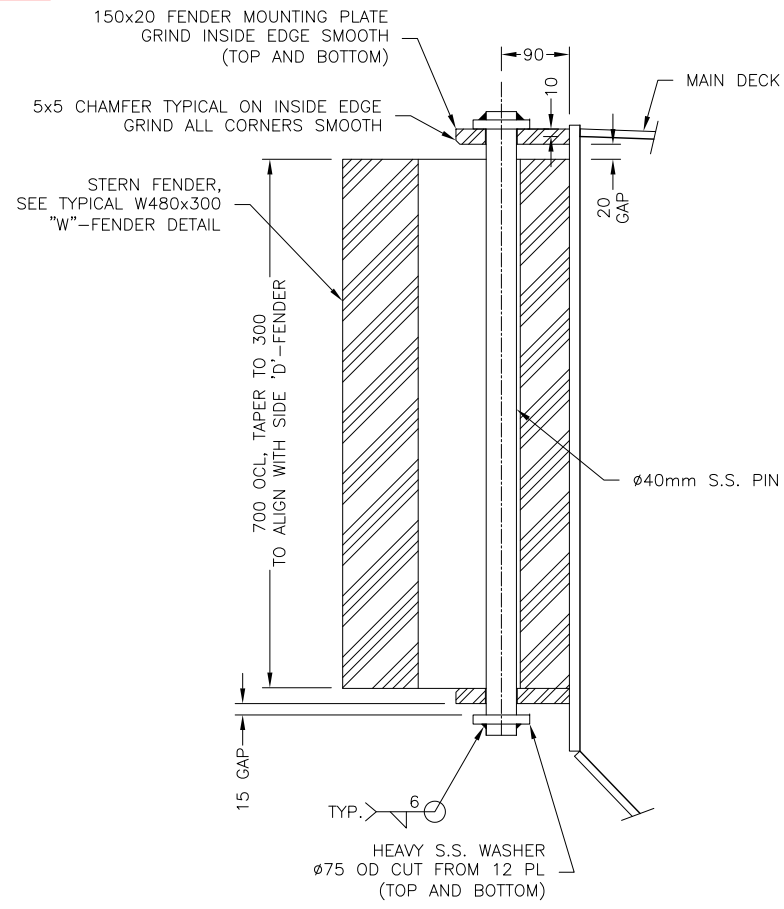

VIEW A-A  
AFT 'W'-FENDER

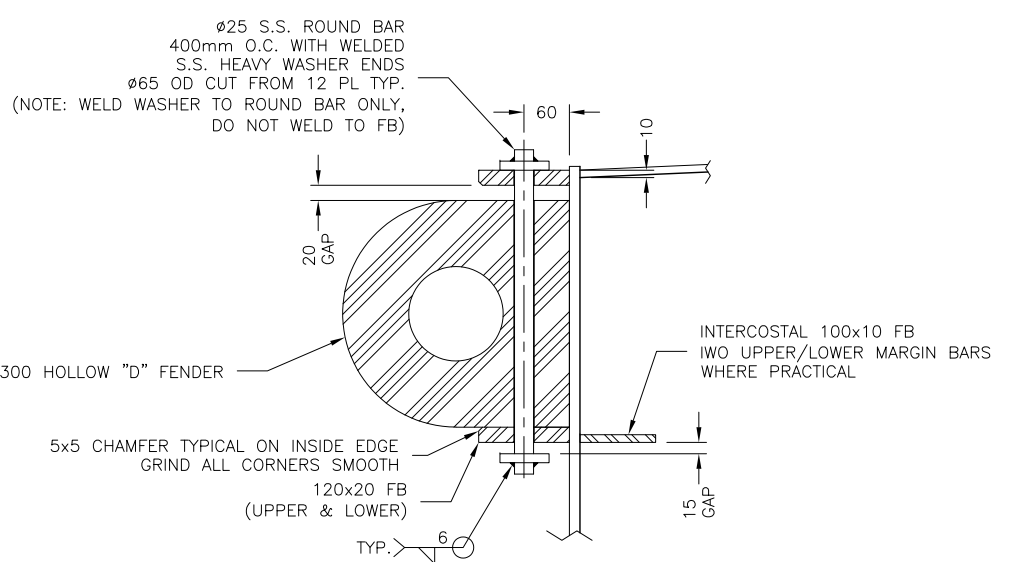

VIEW B-B  
SHEER 'D'-FENDER

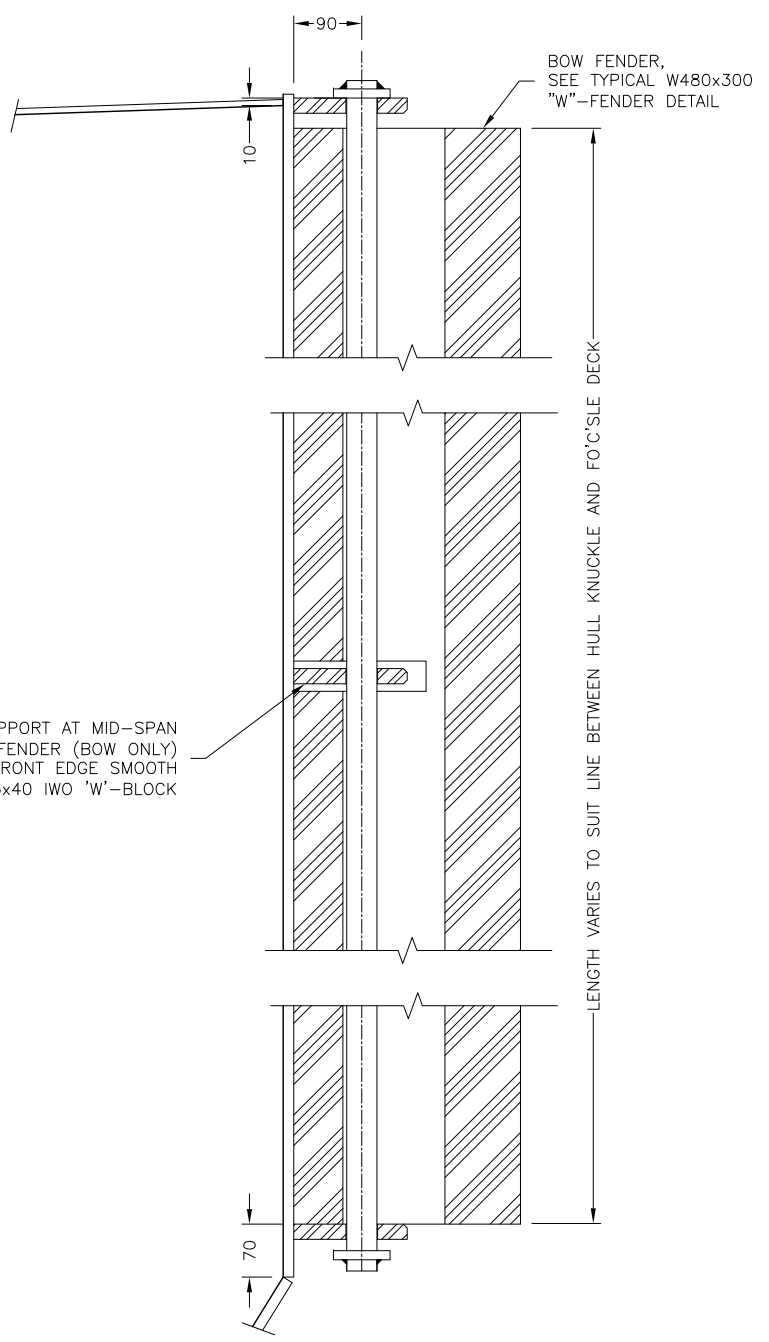

VIEW C-C  
FORWARD 'W'-FENDER  
DETAILS SIMILAR TO VIEW 'A-A', UNLESS NOTED OTHERWISE

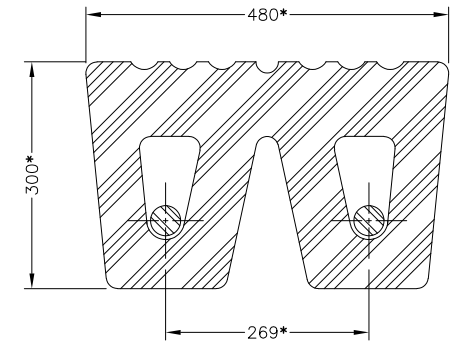

TYPICAL W480x300 'W'-FENDER DETAIL  
\*DIMENSIONS SHOWN FOR REFERENCE ONLY  
REFER TO FINAL SELECTED EQUIPMENT FOR DETAILS

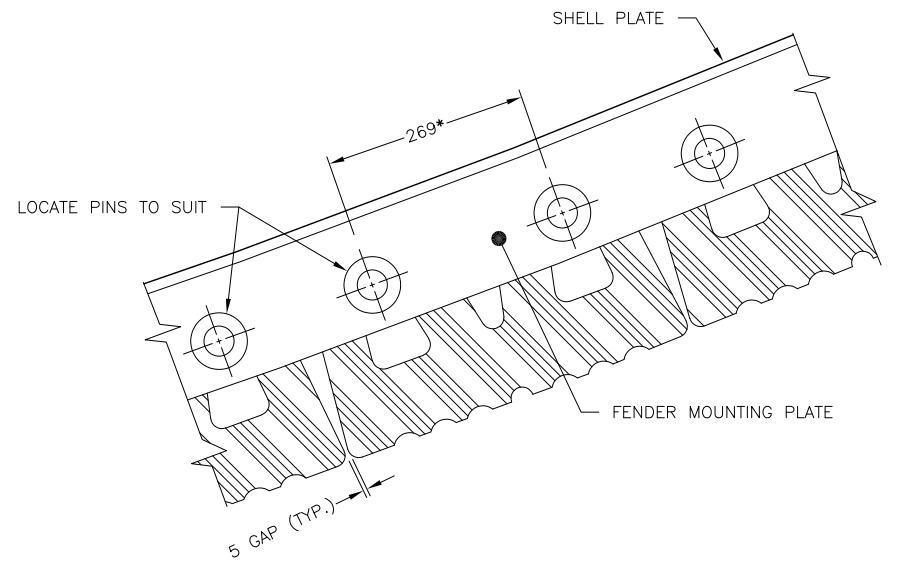

TYPICAL W480x300 MOUNTING PLAN  
\*DIMENSIONS SHOWN FOR REFERENCE ONLY  
REFER TO FINAL SELECTED EQUIPMENT FOR DETAILS

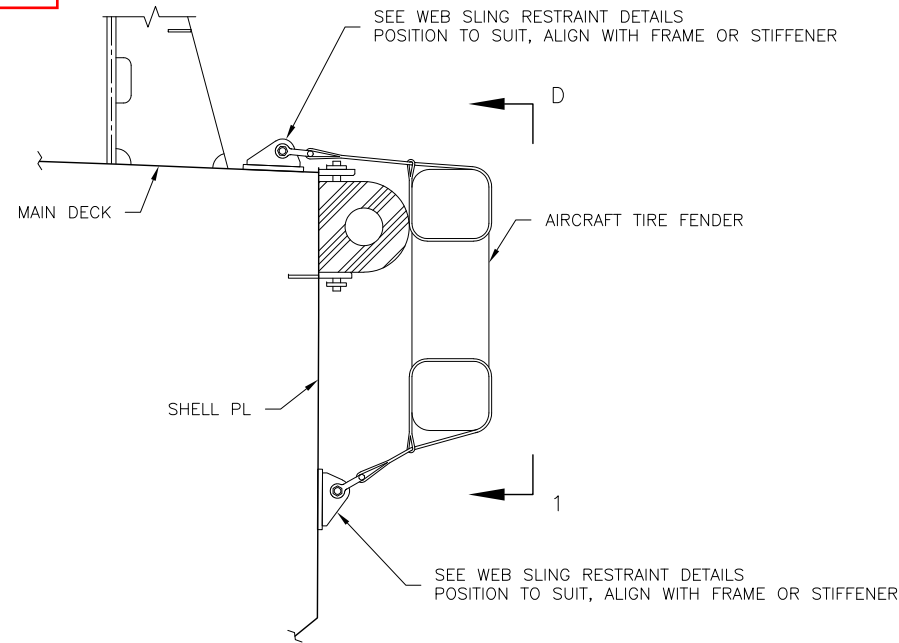

DETAIL 'D' - AIRCRAFT TIRE MOUNTING  
TYPICAL AIRCRAFT TIRE MOUNTING. ADJUST TO SUIT

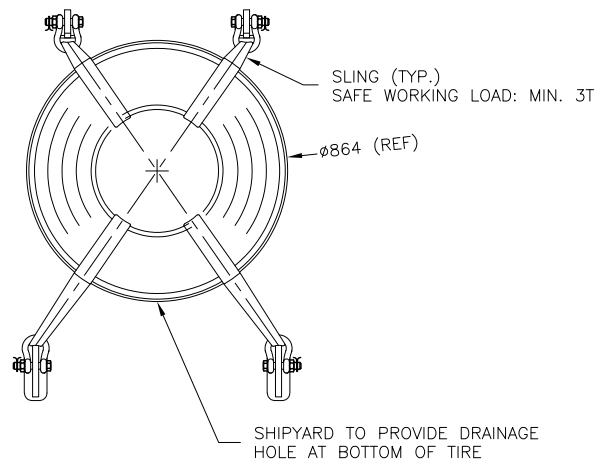

VIEW 'D-1'

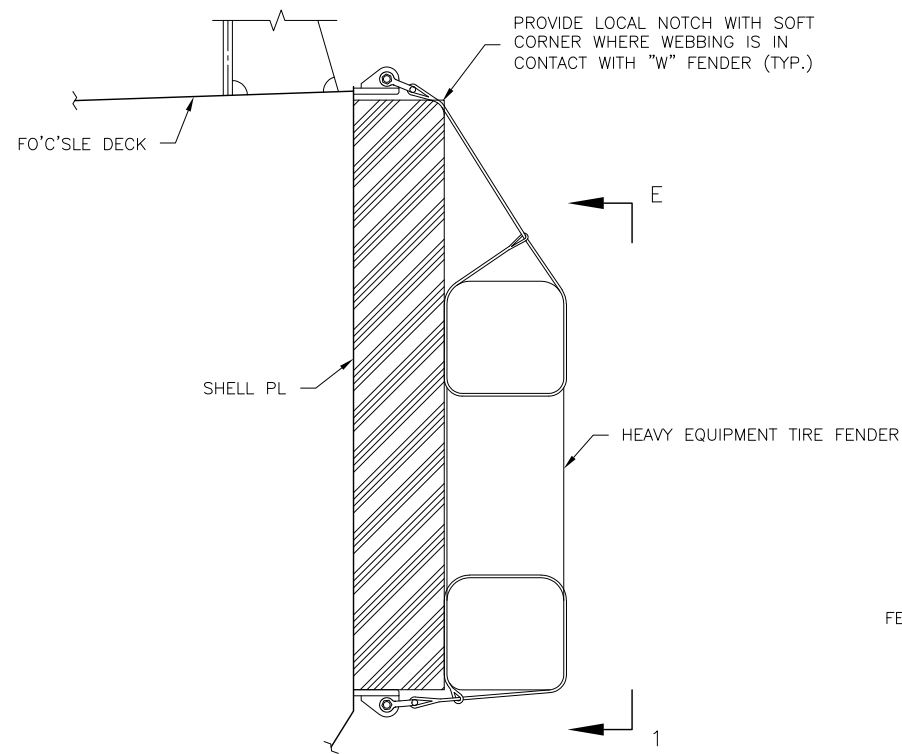

DETAIL 'E' - EQUIPMENT TIRE MOUNTING  
TYPICAL EQUIPMENT TIRE MOUNTING. ADJUST TO SUIT

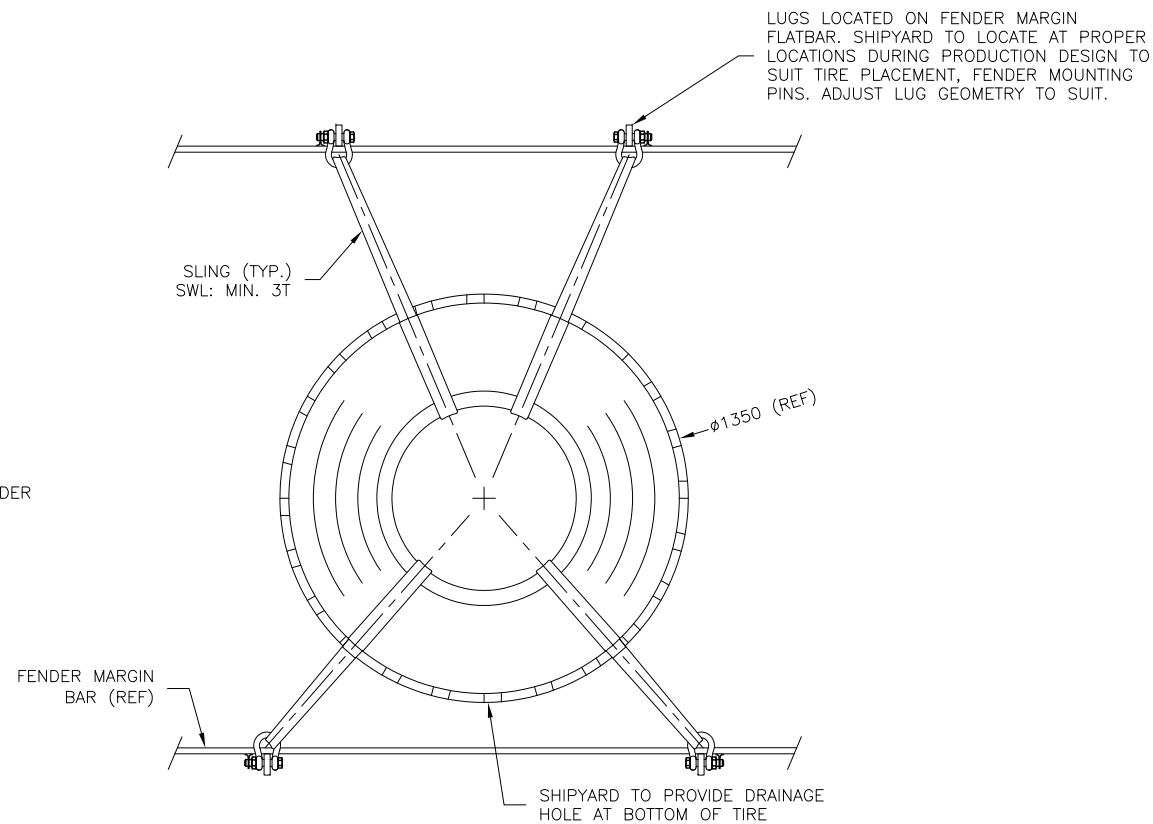

VIEW 'E-1'

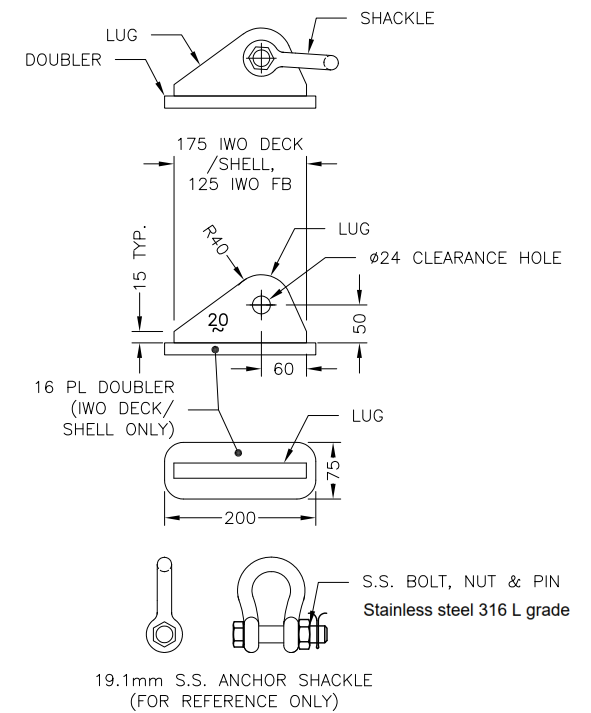

WEB SLING RESTRAINT DETAILS  
FOR REFERENCE, ADJUST TO SUIT (TYP.)  
SCALE: 1:10

**ANNEXURE- 2B**

Sl. No.	Item Description	Dimensions		Unit
		OD of tyre	ID of tyre	
1	<b>Tyre Fender</b>	OD of tyre	ID of tyre	mm
1.a	Heavy Duty Aircraft Tyres			
1.b	Heavy Equipment Tyres			
2	<b>Nylon Sling</b>	Length of sling	*Type of sling	mm
2.a	Nylon Sling SWL: 3T minimum – 4 Nos. for Heavy Duty Aircraft tire with OD Ø864			
2.b	Nylon Sling SWL: 3T minimum – 4 Nos. for Heavy Equipment tire with OD Ø1350			
3	19.1mm SS Anchor Shackle with SS Bolt, Nut & Pin Set (All material SS 316 L Grade)	Standard dimension with MTC		NA

\*OD- Outer Diameter

\*ID- Inner Diameter

\*MTC- Material Test Certificate

**Note :**

1) After placing the Purchase order to L1 bidder , Drawing of the above proposed items is to be submitted by vendor for HCSL approval within 5 days.

2) And method of preservation for items, if required is to be advised by vendor along with above drawings.



PRICE BID FORMAT

Tender Enquiry No: HCSSL/PUR/TEN/2024/042, Dt. 19.11.2024

Sl. No.	Item Description	HSN Code	UOM	Quantity per vessel	Total Quantity for 04 nos. of vessels	Unit rate without GST (INR)	Total Amount Without GST (INR)	GST Amount (INR)
					(A)	(B)	C=A X B	(D)
1	<b>Tyre Fender</b>							
1.a	Heavy Duty Aircraft Tyres		Nos.	20	80			
1.b	Heavy Equipment Tyres		Nos.	5	20			
2	<b>Nylon Sling</b>							
2.a	Nylon Sling SWL: 3T minimum – 4 Nos. for Heavy Duty Aircraft tire with OD Ø864		Nos.	80	320			
2.b	Nylon Sling SWL: 3T minimum – 4 Nos. for Heavy Equipment tire with OD Ø1350		Nos.	20	80			
3	19.1mm SS Anchor Shackle with SS Bolt, Nut & Pin Set (All material SS 316 L Grade)		Nos.	100 Nos. of Set (Inclusive of each item)	400 Nos. of Set (inclusive of each item)			
	<b>Total Amount without GST (INR)</b>							
	Total GST Amount (INR)							
	Total Amount with GST (INR)							

**Price Bid Instructions**

1. Price Bid to be submitted strictly as per format. Modifying the format will result in rejection of the bid.
2. Cost should be inclusive of transit & insurance charges (if any)
3. L1 bidder will be evaluated based on total cost of all items excluding taxes.
4. Quotation for all line items is mandatory. Partially quoting for few line items shall result in rejection of the bid.
5. Freight Charge, if any, should be included in Unit Rate and not to be mentioned as a separate line item.

**Important Note:**

1. Un-priced Bid, to be submitted along with techno commercial bid with details showing whether “Amount quoted/ Nil/ Included “against respective column.

Signature:

Name & Seal , Address of the firm:

**SPECIAL INSTRUCTION TO BIDDER**

**1. MODE OF SUBMISSION OF TENDERS**

Tenders should be submitted in two separate files as **PART-I"TECHNO-COMMERCIAL" & PART-II "PRICE" (Password Protected)** indicating the tender number, due date of the tender in the subject of the Mail and addressed to The Assistant General Manager (Materials).

**2. TECHNO-COMMERCIAL PART SHOULD CONTAIN FOLLOWING DETAILS: -**

- I. Specification & Technical Literature, if any.
- II. Other conditions, if any
  - a. Signed and stamped copy of Scope of supply & Technical Specification (Annexure-1)
  - b. Unquoted Price bid (Annexure-3)
  - c. Special Instruction to Bidder (Annexure-4)
  - d. General Terms and Conditions (Annexure-5)
  - e. SD/Bank guarantee format. (Annexure-8)
  - f. List of Deviations (Annexure-9)
  - g. Product Specification, such as details of make/ brand name of tyre and its basic dimensions, details of accessories etc., to be provided as per Annexure-2.

**3. PRICE PART SHOULD CONTAIN FOLLOWING DETAILS: -**

- a. Price against item.
- b. Taxes & duties as applicable shall be indicated.

**Note:**

- i. Modification or alteration of the price bid format attached is strictly prohibited. Otherwise Bid will be liable for rejection.
- ii. In case Price bid is placed inadvertently in the Techno-Commercial Part or in case Price bid is not password protected, Bid will be straightway rejected.

**4. While submitting the bid, bidders are requested to note that the e-mail ID starting with following words may probable be treated as spam, not always necessary-**

info, support, admin, sales, customer support,helpdesk,mail,mailadmin, billing, hello,careers.

**Bidders are requested to submit the bid by e-mail (Price part password protected) only** to both the following email address clearly mention the tender reference in the subject line for easy identification.

[johnson.g@hooghlycsl.com](mailto:johnson.g@hooghlycsl.com)

[girish.gupta@hooghlycsl.com](mailto:girish.gupta@hooghlycsl.com)

**5. The Techno-commercial part alone will be opened initially on the due date and time of tender. The price part will be opened only after evaluation of the Techno commercial part. Bidders will be intimated the date of opening of the price part, whose techno- commercial bids are acceptable in due course. Password of price bid will require to be shared at the time of price bid opening.**

**6. Deviations, if any, in the offer submitted from that of the tender enquiry in any form, should be clearly furnished in a separate document titled as "List of Deviations".**

7. After submission of quotation / price bid opening, no unsolicited correspondence will be entertained.
8. Clarifications, either technical or commercial, should be submitted to points specially asked for only. The opportunity so given should not be used for correcting/changing amending the data/conditions already submitted with the tender.
9. Offers should be clear and unambiguous. Incomplete/ambiguous offers are likely to be rejected.
10. The bidder shall submit a signed & stamped copy of the tender document including Annexures and Enclosures along with their bid as token of acceptance of terms & Conditions.



**For Hooghly Cochin Shipyard Limited**

*Handwritten signature:*  
S. M. Ghosh  
S. M. Ghosh  
S. M. Ghosh

## GENERAL TERMS AND CONDITIONS

SL NO	Description	Compliance by Supplier (YES/NO) In case of non compliance, please provide remarks.
1.	Tenderers are to carefully go through the terms and conditions and the technical specification of the items for which offers are called for. Tenderers have to adhere to above and supply full technical scope of items along with compliance of commercial conditions. HCSL have full right upon deviations, if any, including rejecting the partial scope/ complied offers.	
2.	Offers are to be free from overwriting. Corrections and additions, if any, must be attested. The offers shall be submitted only through email. Incomplete/ambiguous/conditional offers are likely to be rejected.	
3.	Bidders can contact Officer-in-charge of the work which is indicated in the Tender Notice for any clarification before submitting the offer. If clarifications/details are not obtained before the offer is submitted, no claim on this account will be admitted.	
4.	Technical checklist, if applicable and current general terms & conditions of enquiry duly filled and signed and technical specifications of items offered, should be submitted along with part-I techno-commercial bid. Non receipt of the document may lead to rejection of offers.	
5.	<b>SPECIFICATIONS:-</b> a) Manufacturer's name, their trade mark and brand, if any, should invariably be mentioned and illustrative leaflets giving technical particulars (technical details of items offered including technical literature) etc., should be attached to the offer.	
	b) Materials offered shall conform to HCSL specifications and drawings.	
	<del>c) Samples are to be supplied free of cost in the event of requirement by HCSL. The detailed working drawing, if called for, is also to be furnished for approval before commencement of manufacture.</del>	
6.	Packing materials should be eco friendly.	
7.	Supplier should follow the statutory requirements of product offered.	
8.	Products supplied shall be non toxic and harmless to health. In case of toxic materials, Materials Safety Data Sheet may be furnished along with the material.	
9.	Taxes and duties, if any, payable extra are to be included in the price part.	

10.	Delivery time required for supplies compiling as per offer.	
11.	<b><u>SHIPMENT</u></b> a. Supplier shall intimate HCSL the readiness of the items prior to fourteen days of shipment.	
	<del>b. A minimum 14 days free detention period is to be granted for clearance of the goods at Kolkata Seaport/Airport, as applicable for full containers.</del>	
12.	<b><u>PAYMENT TERMS:</u></b> HCSL payment term is 95% along with 100% applicable taxes within 30 days from the date of receipt and acceptance of items/vessel as per tender at HCSL stores after inspection and balance 5% on satisfactory completion of Guarantee period and certification by HCSL. (For staggered delivery staggered payment applies. However supply of all items against shipset to be completed for part payment)	
	b) Payment mode shall be Electronic Clearing System (ECS)/cheque /NEFT/ /LC/CAD/TT-as mutually agreed in line with above standard payment terms. Variations from standard terms, if any, shall be appropriately loaded for tender comparison purposes for arriving the lowest bid. Bank charges (including LC charges, if any) inside India will be to HCSL account and outside India to supplier's account (In the case of import shipments). The charges for LC amendment, if any, shall be borne by the parties by whom the same is attributed/ necessitated.	
	c) Normally advance payments are not encouraged. In case, if advance payment is sought, the same can be considered for a maximum of 10% order value only. Interest at the base rate of SBI {applicable on the date of price bid opening} + 1% for the amount of advance will be charged. In addition, Bank guarantee for equivalent amount of advance to cover the period till advance payment is adjusted to be furnished. (ie till completion of supplies or for a period as specifically agreed + 90 days). In case interest as above is not agreeable to be paid, the same will be loaded on your quoted basic prices, for tender comparison purposes for arriving the lowest bid .	
	d) For deviation in Payments terms from HCSL standard, if any, aforesaid interest will be loaded on quoted item basic prices, for tender comparison purposes.	
	e) Part payment shall be considered only if specifically agreed against partial supplies.	
13.	<b><u>a) Security Deposit/ Warrantee Bank Guarantee: (Only applicable if order value is above 20 lakhs)</u></b> i) The successful bidder shall remit a security deposit of 3% of the total order value (excluding taxes, duties etc.) in the form of demand draft drawn in favor of Hooghly Cochin Shipyard Ltd. towards the satisfactory performance of the contract, if an order is placed on them. Alternatively, a Bank Guarantee equivalent to above % of the total order value (excluding taxes, duties) as per HCSL format from an International Bank as per approved list of banks available in CSL website (for overseas supplier) & Scheduled Indian bank for Indian supplier is to be submitted, if an order is placed towards satisfactory performance of the contract.	

	<p>ii) The supplier shall also agree for 3% of total order value (excluding taxes and duties) as Bank guarantee towards the Guarantee clause.</p> <p>iii) The Bank Guarantee /DD as above should be initially valid till 90 days after completion of supplies in terms of SD and later revalidated (within the validity of initial BG) to cover the guarantee period plus 90 days.</p>	
	b) SD to be submitted within 2 weeks of receipt of order from yard.	
	c) Format of bank guarantee along with enquiry to be agreed as placed at Annexure.9.	
	(e) If the bidder is not agreeable to submission of SD/ warrantee bank guarantee as per HCSL general terms and conditions of enquiry, HCSL reserves the right to reject the offer at our discretion or 3% of total order value (excluding taxes and duties) will be added to the quoted price for tender comparison/ evaluation purpose on case to case basis for arriving the lowest bid.	
14.	<p><b>Risk Purchase:</b> If the supplier fails to supply the items ordered in good quality as per contract specification and fails to deliver within the delivery date or violate any of the terms and conditions of the purchase order, HCSL shall have the following rights.</p> <p>a. To cancel the order partially or full with 15 days notice and to forfeit the security deposit, if any.</p> <p>b. To impose tender holiday for the vendor for an appropriate period as decided by HCSL.</p> <p>c. To initiate alternate procurement action at the risk and cost of the supplier.</p>	
15.	<p><b>Liquidated Damage:</b> In case of delay in supply of ordered materials beyond the stipulated delivery period, which is not attributable to HCSL, supplier is to pay Liquidated Damages (and not by way of penalty) a sum equivalent to ½% (half percent) per week or part of the week of the value of the items delayed, subject to a maximum of 10% of the value of item delayed. (Total basic price is the order value excluding freight, taxes, other charges etc. However LD applicability is without prejudice to HCSL right to terminate contract for delayed delivery or other actions as per risk purchase clause.</p>	
16.	<p><b>Warranty/Guarantee</b></p> <p>a) The Items supplied shall be guaranteed for rated performance and against damage or failure due to faulty design, defective materials and bad workmanship for a period from delivery of items until 6 months from the date of launching of the ship OR 12 months from delivery of items to Yard, whichever is earlier. Should such damage/failure occurs within the Guarantee period, the Supplier should immediately rectify the failure by repair/replacement of any such part found to be under performing/ defective, at his own expenses.</p> <p>b) Further to equipment guarantee, replaced/repared items shall be guaranteed for 12 months from date of repair/replacement.</p> <p>c) Replacements during guarantee period to be sent on Duty and all taxes paid basis to location as required by yard/vessel owner with all expenses to supplier account.</p>	
17.	<p><b>Jurisdiction:</b> All questions, disputes or difference arising under, out of, or in connection with contracts shall be subject to the exclusive jurisdiction of the Courts at Kolkata,</p>	

	West Bengal, India. Alternate dispute resolution mechanism can also be considered.	
18.	<p><b><u>Force Majeure condition:</u></b> Should failure in performance of the contract or part thereof arise from war insurrection, restraint imposed by Government, Act of Legislature or other Statutory Authority or illegal strike, riot, legal lock-out, flood, fire, explosion, act of God or any inevitable or unforeseen event beyond human control which may be construed as reasonable ground for an extension of time, HCSL may allow such additional time as is mutually agreed, to be justified by the circumstances of the case. The occurrence/cessation of force majeure situation is to be informed with documentary evidence within 15 days from the date of occurrence/ cessation.</p>	
19.	Clarifications, either technical or commercial, should be submitted to points specially asked for only. The opportunity so given should not be used for correcting/changing/amending the data/conditions already submitted with the tender	
20.	<p><b>Validity:</b> a. Prices should be valid for acceptance for a period of four months from the date of tender opening.</p> <p>b. No enhancement of rate for whatsoever cause will be allowed once the offer is accepted and an order is placed. Withdrawal of the quotation after it is accepted or failure to make the supply within the stipulated delivery period, will entail cancellation of the order and forfeiture of Earnest Money Deposit/Security deposit, if any and/or risk purchase, without prejudice to other penal actions, including tender holiday after serving show cause notices, as deemed fit.</p> <p>c. Conditional discounts, if any, will not be reckoned for tender evaluation/ comparison purpose. However, if the bidder becomes L1 at original offer, conditional discount shall also be considered.</p> <p>d. Unpriced bid (price bid without price) duly signed is to be submitted along with techno-commercial offer in the price format, provided. Price should be quoted separately for each item shown in the format. In the event price bid is different from the unpriced format already submitted, yard reserves the right to reject the offer at our discretion without any further discussions. Details of optional items, if any, should be indicated under separate heading in the Techno commercial bid and the respective price details should also be given in the price bid. Combining of figures against more than one item and ambiguous clauses will lead to rejection of the bid.</p> <p>e. If, in the price structure quoted for the required material/ item, there is discrepancy between the unit price and the total price (which is obtained by multiplying the unit price by the quantity), the unit price shall prevail and the total price corrected accordingly. If there is an error in a total corresponding to the addition or subtraction of subtotals, the subtotals shall prevail and the total shall be corrected. If there is a discrepancy between words and figures, amount in words of respective figures shall prevail. If the bidder does not agree to the observation of the HCSL, the tender is liable to be rejected and the same shall be intimated.</p> <p>f. After submission of quotation/price offer no unsolicited correspondence will be entertained.</p>	



	g. Hooghly Cochin Shipyard Limited does not bind itself to accept the lowest or any tender but reserves to itself the right to reject any or all or a part of any tender at its discretion.	
21.	<p><b><u>Integrity Pact:</u></b> As per Government of India (Central Vigilance Department), HCSL and the SUPPLIER have to sign an Integrity Pact for the high value contracts, for ensuring transparency, equity and competitiveness in public procurement. The Tenderer has to sign Pre-Contract Integrity Pact as per format enclosed at Annex-7 and to submit along with your offer. The above is applicable when the total basic price is above INR. 100.0 lakhs. (present limit)</p>	
22.	<p><b>SUB CONTRACTING AND ASSIGNMENT</b> Supplier shall not contract with any subcontractor and/or vendor without the prior written consent of HCSL. Such consent shall not relieve the Supplier from any of his responsibilities and liabilities under the Purchase Order. In addition, Supplier shall ensure that the terms and conditions of any such contract shall comply with and correspond to the terms and conditions of the Purchase Order.</p>	
23.	<p><b><u>General:</u></b> a. Prior to price bid opening, HCSL is at liberty to take the credit rating of bidders at our cost on case-to-case basis, and to include the same during the evaluation of the tender. b. Deviations, if any in the techno-commercial offer from that of the tender enquiry in any form should be clearly furnished in a separate document titled as "List of Deviations" (Refer Annexure-5), failing which it will be presumed that all the terms and conditions are acceptable. c. The techno-commercial part alone will be opened initially on the due date of tender. The price part will be opened only after evaluation of the Techno commercial part. Date of opening of the price part will be intimated to those firms whose Techno- commercial bids would be acceptable after the evaluation. Suppliers shall not depute their representative to HCSL at the time of tender opening.</p>	
24.	<p><b><u>Purchase Order</u></b> :- a. In the event supplier's offer leads to an agreement to effect supplies, a formal purchase order shall be issued by HCSL on the basis of agreed terms and conditions of tender. b. Upon placement of order (by post or mail) the supplier shall submit the acknowledgement (ie: signed and stamped original/ scanned soft copy by mail) as a token of acceptance of order within 15 days. In case HCSL doesn't receive the above, it will be deemed as accepted.</p>	
25.	<p><b><u>Inspection:</u></b> - a) HCSL reserve the right to inspect the goods after receipt at HCSL store / prior to dispatch (by HCSL or HCSL authorized agency at yard cost). Short supply / Mismatch / Replacement of Defective items / those not meeting agreed / contractual specification/ Items failing during commissioning shall be sent on air freight/ DDP basis courier freight prepaid/delivered at HCSL store. b) Replacements during guarantee period to be sent on Duty and all taxes paid basis to location as required by yard/vessel owner with all expenses to supplier account.</p>	

	<p>c) Defective items, if any, after receipt shall be sent back on cost, carriage, handling and insurance prepaid basis including re-export (wherever desired by supplier) to be arranged by supplier. Defective items shall be returned after receipt of replacement item. Supplier, shall replace all/ part of items as applicable, in case of rejection, within 4 weeks of reporting the defect, without any additional cost to HCSL. In case the defective materials are not taken back within the said period, HCSL reserves the right to dispose the same without further intimation.</p>	
	<p>d) The supplier shall compensate HCSL for loss on account of shortage in quantity and number of pieces received than that indicated in the bill of lading provided the HCSL's claim is rejected by the insurance due to any fault of supplier. Such claims, if any, shall be supported by recognized surveyors report. The supplier shall also compensate for losses, if any sustained by the HCSL due to defective packing and/or marking of the goods not in accordance with the terms of contract. The time limits for filing claims under clauses above shall be generally 180 days from the date of complete discharge of goods.</p>	
26.	HCSL reserves the right to alter, modify the scope of supply at its discretion and in consistent with the policy of the Government of India and statutory bodies under them as applicable to the contract from time to time.	
27.	HCSL reserves the right to commercially reject the offer if compliance is not issued to General terms and conditions without any further clarification / notice / communication in this regard from M/s. Hooghly Cochin Shipyard Ltd., even though the offer is technically acceptable.	
28.	Items supplied from border sharing countries with India are restricted as per Annexure-4.	
29.	Bidder has to submit the main dimension of tyre list of spare parts, tools & other accessories etc. as per Annex-1 along with the technical bid.	

**Specify Yes / No**

**Tender conditions for Restriction of bidders sharing land border with India vide Office memorandum dt 23.7.2020 Order - Public Procurement no 1 dt 23.7.2020, Order no 2 dt 23.7.2020 and Order no 3 dt 24.7.2020**

A	Requirement of registration
1	Any bidder from a country which shares a land border with India will be eligible to bid in this tender only if the bidder is registered with competent authority as per C below .In works contracts , including turkey contracts , contractors shall not be allowed to sub contract works to any contractor from a country which shares a land border with India unless such contractor is registered with Competent authority. Relevant certificate to be submitted by bidder from a country which shares land border with India except for bidders to which Govt of India has extended lines of Credit or in which Govt of India has development projects,alongwith the offer as proof of registration with competent authority , failing which the offer will not be considered. A certificate is to be submitted by the bidder for compliance with the order referred above alongwith tender documents for consideration of offer (Wordings are as per Clause below) .If such certificate given by a bidder whose bid is accepted is found to be false, this would be a ground for immediate termination and further legal action in accordance with law.
2	Wordings of certificate to be submitted alongwith tender documents
	I have read the clause regarding restrictions on procurement from a bidder of a country which shares a land border with India. I hereby certify that this bidder is not from such a country or, if from such a country, has been registered with the competent authority. I hereby certify that this bidder fulfils all requirements in this regard and is eligible to be considered. (Evidence of valid registration by the competent authority shall be attached wherever applicable).
2	Wordings of certificate to be submitted alongwith tender documents for Works involving possibility of sub contracting
	I have read the clause regarding restrictions on procurement from a bidder of a country which shares a land border with India and on sub contracting to contractors from such countries. I certify that this bidder is not from such a country or if from such a country has been registered with the competent authority and will not subcontract any work to a contractor from such countries unless such contractor is registered with the competent authority. I hereby certify that this bidder fulfils all requirements in this regard and is eligible to be considered(Evidence of valid registration by the competent authority shall be attached wherever applicable)
B	Validity of registration
1	Registration should be valid at the time of submission of bids and at the time of acceptance of bids. In respect of supply otherwise than by tender, registration should be valid at the time of placement of order.If the bidder is validly registered at the time of acceptance /order placement , registration shall not be a relevant consideration during contract execution.
C	Competent authority and Procedure for registration

1	The competent authority for the purpose of registration under the order shall be Registration committee constituted by the Department of Promotion of Industry and Internal Trade (DPIIT). Details of the committee and procedure for registration and restrictions shall be as per Ann I of the Order - Public Procurement no 1 dt 23.7.2020 issued by Ministry of Finance , department of Expenditure.
<b>D</b>	<b>Definition of Bidder and Bidder from a country sharing land border with India</b>
1	Bidder is defined as any person or firm or company including any ,member of a consortium or joint venture , every artificial, juridical person not falling in any of the descriptions of bidders stated hereinbefore , including any agency , branch or office controlled by such person , participating in a procurement process.
2	<p>"Bidder from a country which shares a land border with India" for the purpose of this Order means:-</p> <ul style="list-style-type: none"> <li>a) An entity incorporated, established or registered in such a country; or</li> <li>b) A subsidiary of an entity incorporated, established or registered in such a country; or</li> <li>c) An entity substantially controlled through entities incorporated, established or registered in such a country; or</li> <li>d) An entity whose beneficial owner is situated in such a country; or</li> <li>e) An Indian (or other) agent of such an entity; or</li> <li>f) A natural person who is a citizen of such a country; or</li> <li>g) A constitution or joint venture where any member of the consortium or joint venture falls under any of the above.</li> </ul>
3	<p><b>Type of business entity</b>  (Private Limited Company/ Public Limited Company/ Sole Proprietorship/ One Person Company/ Partnership/ Limited Liability Partnership/ Joint Venture/ Trust/ NGO)  In case of incorporated entity - to attach certificate of incorporation</p>
	<p><b>Beneficial Owners</b>  - as defined in the Department of Expenditure Order (Public Procurement No.1) issued vide No. F.No.6/18/2019-PPD dated 23<sup>rd</sup> July, 2020.  Details of all beneficial owners having entitlement of more than 01% of shares or capital or profit to be given, in the format as given in Annexure-I duly certified by practicing Chartered Account in India.</p>

<b>Tender condition - Preference to Make in India</b>	
A	Purchase preference in accordance with Public procurement (Preference to Make in India Order – 2017) Order from Department of Promotion of Industry and Internal Trade P – 45021 /2/2017/-B.E –II dt ,4.6.2020 and as amended from time to time shall be applicable as per below
1	In the procurement of all goods/services/works in respect of which there is sufficient local capacity/local competition , only Class I Local suppliers shall be eligible to bid irrespective of purchase value
2	In the procurement of all goods/services /works which are not covered as above and with estimated value of purchase less than Rs 200.0 Crores , only Class I local suppliers alongwith Class II local suppliers shall be eligible to bid.
<b>Purchase preferences for Class I local suppliers</b>	
B	In the procurement of goods/works covered under 2 above and which are divisible in nature , Class I local supplier shall be eligible for Purchase preference over Class II/Non local supplier as per following
1	If L1 bid is not a Class I local supplier , 50% of the order quantity shall be awarded to L1. Thereafter the lowest bidder among Class I local supplier will be invited to match the L1 price for the remaining 50% quantity subject to Class I local supplier quoted price falling within 20% margin. Contract for that quantity shall be awarded to such Class I local supplier subject to matching L1 price. In case such lowest eligible Class I local supplier fails to match L1 price or accept less than offered quantity , next higher Class I local supplier within 20% margin shall be invited to match the L1 price for the remaining qty and so on . If some quantity is left uncovered on Class I local supplier , such balance quantity shall be ordered on L1 bidder.
2	For procurements that are not divisible in nature and in procurement of services evaluated on price alone , Class I local supplier shall get purchase preference over Class II/Non local supplier as per below

3	If L1 is not a Class I local supplier , lowest bidder among Class I local supplier will be invited to match L1 price subject to Class I local supplier quoted price falling within 20% of L1 price and contract will be awarded to such Class I local supplier,subject to matching L1 price. In case such lowest eligible Class I local supplier fails to match L1 price, procedure same as para 3 above will be opted .In case none of Class I local suppliers within 20% margin matches L1 price, contract shall be awarded to L1 bidder. The purchase preference as above will be only for Class I local supplier and Class II local supplier will not be eligible for any Purchase preference
C	Local content requirement to categorise a supplier as Class I/ClassII/Non local supplier shall be as per below . Definition of local content shall be as per order dt 4.6.2020 ie amount of value added in India which shall be the total value of the item procured (excluding net domestic indirect taxes) minus the vaue of import content in the item (including all customs duties) as a proportion of total value in percentage.
1	Class I –Local content equal to or greater than 50%
2	Class II–Local content greater than 20% , less than 50%
3	Non local –Local content less than 20%
D	<b>Declaration of local content</b>
1	Class I local supplier /Class II local supplier at the time of tender shall indicate % of local content and provide self certification that offered item shall meet the local content requirement for ClassI/Class II as applicable including details of locations at which local value addition is made.
2	In case of procurement for a value in excess of Rs 10.0 Crores Class I/ClassII local supplier is to provide a certificate from statutory auditor/cost auditor(for companies) /practising cost accountant/Chartered accountant (suppliers other than companies) indicating % of local content
3	Verification of the Certificates issued by the bidder shall be carried out by HCSL onrandom basis. False declarations will attract actions as stipulated in the order referred , including other actions as permissible by law.
4	Exemption is applicable from provisions of order for purchases with estimated values less than Rs 5.0 lakhs
5	Notwithstanding above , exemptions for meeting local content as per relevant Clause of order dt 4.6.2020 and as amended from time to time shall apply.

COMPLIANCE STATEMENT- SPECIAL INSTRUCTIONS FOR TENDERERS AND TECHNICAL SPECIFICATION		<b>PAGE 1 OF 1</b>
Tender Name: <b>Procurement of Tyre Fender with Accessories for Tugs at Hooghly Cochin Shipyard Ltd. Nazirgunge Unit, Howrah (Detailed specification is enclosed separately)</b>		
TENDER NO: HCSL/PUR/TEN/2024/042, Dt. 19.11.2024		
We hereby confirm and truly declare that our Offer / Bid No. ....dated .....is in full compliance with the documents issued against the Tender No. -----dated -----, except for the deviations listed below: LIST OF DEVIATIONS (HCSL reserves the right to reject offers with deviations)		
<b>Sl. No.</b>	<b>Tender Reference &amp; Description</b>	<b>Reasons for Deviation/Remarks</b>
Name of tenderer: Date: _____ Name & Designation _____ Seal & Signature _____  (Company Seal)		

\*\*\*

**BANK GUARANTEE IN LIEU OF SECURITY DEPOSIT/  
WARRANTY GUARANTEE**

To

HOOGHLY COCHIN SHIPYARD LTD

(Govt. of India Enterprise,)

Satyen Bose Road,

Danesh SK Lane (PO),

Nazirgunge, Howrah,

West Bengal - 711109.

WHEREAS.....(Name & Address of Supplier)  
(hereinafter called" **the Supplier**") has undertaken , in pursuance of  
Contract.....No.....Dated:.....  
...to execute.....(Name of Contract and brief description of  
works)(hereinafter called" **the Contract**").

AND WHEREAS it has been stipulated by **HOOGHLY COCHIN SHIPYARD LTD** (The  
Buyer – hereinafter called "**HCSL**") in the said contract that the Supplier shall furnish **HCSL**  
with a Bank Guarantee for the sum specified therein as security for compliance with the  
Supplier's obligations in accordance with the Contract.

AND WHEREAS we have agreed to give the Supplier such a Bank Guarantee.

NOWTHEREFORE we.....(Name of the Bank) having its Head Office  
at.....(Address of Head Office)and acting through its branch office  
at.....(Address of the executing branch)(hereinafter called" the Bank")  
hereby affirm that we are the Guarantor and responsible to **HCSL**, on behalf of the Supplier  
upto a total of.....(amount of Guarantee) in words).

We, the bank, hereby irrevocably undertake to pay you any amount not exceeding in total  
the Guarantee Amount upon receipt by us of your demand in writing accompanied by the  
following documents:

1. Your signed statement certifying that the Supplier is in breach of his  
obligation(s)under the Contract and the respect in which the Supplier is in breach.
2. Your signed statement certifying that the Supplier has been given a prior written  
notice by email from you to make good the aforesaid breach and that the Supplier  
still failed to fulfill the Contract within 30 days of such notice. A copy of such notice  
given by email to the Supplier shall be attached to the demand for payment.

Any demand for payment should contain your authorized signatures which must be authorized  
by your bankers or by a notary public.

We, the Bank, further agree that no change or addition to or other modification of the terms  
of the Contract or of the Works to be performed there under or of any of the Contract  
documents which may be made between **HCSL** and the Supplier shall in any way release us



from any liability under this guarantee, and we hereby waive notice of any such change, addition or modification. We, the Bank, further agree that any change in the constitution of the said contractor or the said bank shall not discharge our liability hereunder.

**Notwithstanding** anything contained herein:

1. Our liability under this Bank Guarantee shall not exceed .....(only).
  
2. This Bank Guarantee shall be valid upto (date)and
  
3. We are liable to pay the guaranteed amount or any part thereof under this bank guarantee only and only if HCSL serve upon us a written claim or demand on or before.....(validity date).

Any demand for payment under this guarantee must be received by us at this office during working hours on or before the validity date. Should we receive no claim from you by the validity date, our liability to you will cease and the guarantee will definitely become null and void whether returned to us or not.

Yours truly,

Signature and seal of the

guarantor:.....

Name of

Bank:.....  
.....

Address:.....

Date:.....

1An amount shall be inserted by the Guarantor, representing the percentage of the Contract Price specified in the Contract and denominated in respective Dollars / Indian Rupees/Other Currency.