

NOTICE INVITING TENDER

Sealed competitive tenders are invited on behalf of Hooghly Cochin Shipyard Limited (HCSL) from experienced vendors for the under mentioned work, so as to reach the undersigned on or before the date and time mentioned below. Please refer Scope of Work, General Terms and Conditions and Special Terms attached.

Tender No. & date	HCSL/OPS/YS/TEN/026/2024-25, Dated 25-06-2024
Scope of Supply / Work	SUPPLY OF STAGING MATERIALS FOR HCSL, NAZIRGUNGE UNIT, HOWRAH, W.B.
Type of Tender	Two Bid
Cost of tender form	NIL
Earnest Money Deposit (EMD)	100000.00
Last date & time of receipt of tender	25-06-2024 at 1500 Hrs.
Date & time of opening of technical bid	10-07-2024 at 1530 Hrs.
Tenure of contract	16 Weeks (from the date of acceptance of work order)
Officer - in - Charge	Name: Siddharth Mohanty Designation: Manager(Marine & Central Services) Email: Siddharth.mohanty@hooghlycsl.com Phone No: +91-7489858690

Tender reference should be clearly indicated on top of the envelope.

Sealed tenders in Single cover system (Prequalification cum Technical and Price Bid) addressed to **The AGM (Planning & Procurement)** shall be dropped in the HCSL tender box or by courier to **Hooghly Cochin Shipyard Ltd (HCSL), Satyen Bose Road, Danesh Sk Lane (PO), Nazirgunge, Howrah, West Bengal, PIN -711109 before the due date and time.**

Tender administration: Tender procedure/administration/evaluation including correspondences will be done M/s. Hooghly Cochin Shipyard Limited, Howrah and awarding of contract will be done by M/s. Hooghly Cochin Shipyard Limited, Howrah, West Bengal.

Signature and Seal of the Bidder(s)

For Hooghly Cochin Shipyard Limited

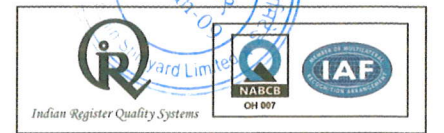
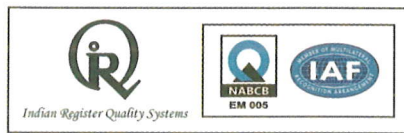

TABLE OF CONTENTS

Sl. No.	Description	Page No.	Annexure No
1	Prequalification Criteria	3	Annexure-1
2	Scope of Supply & Technical Specifications	4	
3	Terms and Conditions	7	
4	Validity of offer	8	
5	Delivery Period	8	
6	Payment terms:	8	
7	Cost of Tender & EMD	8	
8	Security Deposit	9	
9	Indemnity clause	9	
10	Jurisdiction	9	
11	Force Majeure Condition	9	
12	Guarantee Period:	9	
13	Liquidated Damage	9	
14	Risk Purchase	9	
15	Instructions to bidder for submission of quote	10	
16	Price Bid Format	11	Annexure-2
17	Techno-Commercial Checklist	15	Annexure-3
18	Vendor details	16	Annexure-4
19	NEFT Mandate Form	17	Annexure-5
20	List of deviation	19	Annexure-6
21	Form of Bank Guarantee towards EMD	20	Annexure-7
22	Format of security Deposit	22	Annexure-8
23	Form of Self Declaration	24	Annexure-9
24	Form of Legal Cases	25	Annexure-10
25	Undertaking	26	Annexure-11
26	Reference Drawings	27	Annexure-12

Signature and Seal of the Bidder(s)

For Hooghly Cochin Shipyard Limited





A. Prequalification Criteria

Prequalification criteria for participating in the tender will be as follows:

- i. Experience having successfully completed the manufacturing and supply of scaffolding materials during the last 3 years ending last day of month previous to the one in which tenders are invited should be either of the following:
 - a. Three similar completed works (Manufacturing & supply of scaffolding materials) each cost not less than the amount equal to Rs. 24 Lakhs.

OR
 - b. Two similar completed works (manufacturing and supply of scaffolding materials) each cost not less than the amount equal to Rs. 60 Lakhs.

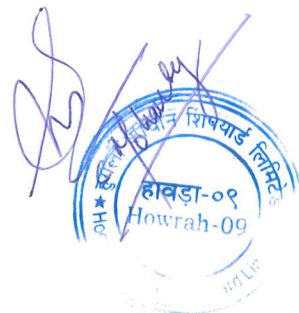
OR
 - c. One similar completed work (manufacturing and supply of scaffolding materials) costing not less than the amount equal to Rs. 96 Lakhs.
- Contractor shall submit the valid proof like Work Orders, Invoice, Work Completion certificates, GSTR-1 for the work carried out against the work credentials.**
- ii. The average Annual Turnover of the bidder should be **at least Rs. 10 lakhs** during the last three preceding years.
 - iii. The bidder must have experience of minimum 3 years in successful completion of **similar work** of nature and complexity comparable to the proposed contract ending last day of month previous to the one in which applications are invited.
 - iv. Audited Balance sheets showing turnover, Profit & Loss account of the firm for the preceding 03 years (FY 2020-21, 2021-22, 2022-23) should be submitted along with the application for prequalification).
 - v. The Tenderer should enclose copy of PAN, GST registration certificate, Income tax returns for last three years. (A copy of the same shall be submitted along with the application for issue of tender document)
 - vi. Offers from joint ventures/consortium will not be accepted.
 - vii. Net worth of the contractor must be positive as per the latest balance sheet. (MSE/NSIC will get exemptions)



		phosphate to be carried out. Pickling/phosphate are to done as per IS standard. To ensure quality, inspection and testing procedure as per IS-3618 will be followed. The procedure & method of pickling / phosphate is to be submitted by the supplier along with Bid.		
6	HOT DIP GALVANIZED ADJUSTABLE BASE JACK	Adj. base jacks shall have 150x150x6mm Base plate with dia 36 mm threaded round bars along with adjustable nut. The adjustable base jacks have to provide 500mm of thread adjustment. Base plate has to be hot dip galvanized to a min 400 GSM / 60 micron (whichever is higher) as per IS 4736 and stud has to be electroplated as per IS1573 Gr2.	200	Nos
7	SWIVEL CLAMP (40 MM x 40 MM, MS ELECTROPLATED)	Any reputed Indian Standard brand and are to electroplated as per IS 1573 Gr2.	200	Nos
8	RIGHT ANGLE CLAMPS (MS ELECTROPLATED)		200	Nos
9	BEAM CLAMP (MS ELECTROPLATED)		200	Nos
10	HOT DIP GALVANIZED STAGING BOARD (50X23X2460 MM)	Staging boards shall be made out of MS Sheet as per IS: 513:2008 of thickness 16-gauge, sectional size 50x235 mm and the length of 2460 mm. Board width shall be 230-235mm to ensure reasonable gap between the boards when laid. The bottom edge of the boards is to be bent about 25 mm towards inside. Steel boards are to be press bent with anti-skid dimples on the top side of the boards. Three stiffeners (03) shall be provided under the boards at equal spacing and enclosing both ends. Post manufacturing each staging boards has to be hot dip galvanized as per IS:4736 and a minimum & uniform zinc deposition (400 GSM / 60 micron) as per IS:4736 has be ensured.	2000	Nos
11	HOT DIP GALVANIZED STAGING BOARD (50X235X1200 MM)	Staging Boards shall be made out of MS Sheets as per IS:513:2008 of thickness 16-gauge, sectional size of 50 x 235 mm and length of 1,200 mm. Board width shall be 230-235mm to ensure reasonable gap between the boards when laid. The bottom edge of the boards is to be bent about 25 mm towards inside. Steel Boards are to press bent with anti-skid dimples on top of the boards. One (1) stiffener shall be provided under the board and enclosing both ends. Post manufacturing, each staging board has to be hot dip galvanized as per IS 4736 and a minimum & uniform Zinc deposition of 400 GSM / 60 microns (whichever is higher) has to be ensured	150	Nos
12	HOT DIP GALVANIZED Monkey Ladder(length-3mtr)	Staging Ladder 3,000 mm long (25 NB 'B' Class Pipes) with 10 Nos. rungs (20 NB 'B' Class pipes) and hooks as per sketch. Post manufacturing, each staging ladder has to be hot dip	200	Nos

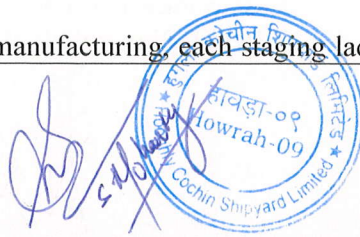

B. Scope of Supply & Technical Specifications

S.No.	Item	Description	Qty	UOM
1	VERTICAL / STANDARD OF LENGTH 3000 MM	<p>Verticals of length 3000mm shall be made of 40 NB Heavy Class continuous welded steel tubes conforming to IS: 1239, Heavy Class or equivalent and have 5 mm thick sockets welded at 50 cm centre for fixing Transoms or Ledgers. Each vertical shall have specially designed captive expanding joint (hollow wedges of 5 mm thickness) working on wedge principles for connecting the vertical together.</p> <p>Verticals are to be applied with one (1) coat of Red Oxide primer and two (2) coats of synthetic enamel paint of Royal Blue colour. Surface preparation by pickling/ phosphating to be carried out. Pickling/ phosphating are to done as per IS standard. To ensure quality, inspection and testing procedure as per IS-3618 will be followed. The procedure & method of pickling / phosphating is to be submitted by the supplier along with Bid.</p>	1000	Nos
2	HORIZONTALS / LEDGER OF LENGTH 2445 MM	<p>Ledgers shall be fabricated with Welded Steel Tubes 40 NB Light Class of the length 2445mm. Either ends of the ledgers shall have captive wedges of 8 mm thick to facilitate connection to the verticals.</p> <p>Ledgers are to be applied with one (1) coat of Red Oxide primer and two (2) coats of synthetic enamel paint of Royal Blue colour. Surface preparation by pickling/ phosphating to be carried out. Pickling and phosphating are to done as per IS standard. To ensure quality, inspection and testing procedure as per IS-3618 will be followed. The procedure & method of pickling / phosphating is to be submitted by the supplier along with Bid.</p>	2000	Nos
3	HORIZONTALS / LEDGER OF LENGTH 1195 MM	<p>Ledgers to be fabricated with Welded Steel Tubes of 40 mm NB Light Class. The length of a ledger is 1,195 mm and either ends of the ledgers are having captive wedges of 8 mm thick to facilitate connection to the verticals</p> <p>Ledgers are to be applied with one (1) coat of Red Oxide primer and two (2) coats of synthetic enamel paint of Royal Blue colour. Surface preparation by pickling/ phosphating to be carried out. Pickling/phosphating are to done as per IS standard. To ensure quality, inspection and testing procedure as per IS-3618 will be followed. The procedure & method of pickling / phosphating is to be submitted by the supplier along with Bid.</p>	120	Nos
5	TRANSOM FOR STAGING 1,195 MM LONG	<p>Transoms shall be fabricated with 50x50x6 mm MS Angles. The length of the transom shall be 1195mm. Either ends of the transoms shall have captive wedges of 8 mm thick to facilitate connection to the verticals.</p> <p>Transoms are to be applied with one (1) coat of Red Oxide primer and two (2) coats of synthetic enamel paint of Royal Blue colour. Surface preparation by pickling/</p>	1000	Nos

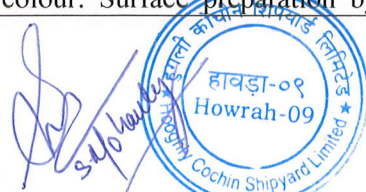

		galvanized as per IS 4736 and a minimum & uniform Zinc deposition as per IS 4736 has to be ensured.		
15	Castrol wheel	8" cast-iron wheel with a PU overlay that is 2 inches wide and over an inch of rubber covering the iron caster wheel with ball bearings in the pivot mechanism to handle high loading. Double zerker grease fittings. Double lock to maintain rock solidness. The stem of the caster wheel should be 38mm OD with a 8" length Threaded with Wing nut to adjust the height.	25	Nos
16	40 NB PIPE (C CLASS) 6,000MM LONG	As per IS 1239, Pipes are to be applied with one (1) coat of Red Oxide primer and two (2) coats of synthetic enamel paint of Royal Blue colour.	100	Nos

Note:

1. Raw materials:

- All the Raw materials used for the fabrication of staging materials to be sourced from reputed makes like TATA, Jindal, SAIL, Utkarsh, APL apollo, Nippon Tubes Ltd, Surya Roshni etc.
- Paints to be procured from reputed makes like Jotun, AkzoNobel, Berger, Nerolac or Asian Paints.
- Manufacturer Test Certificates (MTC) to be provided for HCSL records.
- Transportation and Transit insurance shall be in the scope of supplier and unit prices quoted are to be inclusive of the same.
- Packing Material should be eco-friendly.
- Supplier should follow the statutory requirements of products offered.
- Products supplied shall be nontoxic and harmless to health. In the case of toxic materials Material Safety Datasheet may be furnished along with the material

2. Surface preparation & Painting:

- Surface preparation by pickling/ phosphating to be carried out. Pickling/ phosphating are to done as per IS standard. To ensure quality, inspection and testing procedure as per IS-3618 will be followed. The procedure & method of pickling / phosphating is to be submitted by the supplier along with Bid.
- Staging Boards and Staging Ladders are to be Hot Dip Galvanized to a minimum and uniform GSM of 400 as per IS 4736. The Ledgers, verticals and transoms are to be applied with one (1) coat of epoxy Red Oxide Primer and two (2) coats of epoxy anticorrosive Paint of Royal Blue from reputed manufacturers.
- The finish coat color prior approval shall be obtained from officer in-charge before proceeding with final paint application.**

- 3. Inspection:** Raw materials shall be presented for inspection by CSL representative prior to commencement of fabrication. Fabricated items shall also be presented for further inspections prior to painting and before dispatch. Stage, final and receipt inspection at shipyard, of the items will be carried out as per the discretion of CSL. All the relevant test certificates of Raw materials and final deliverables to be submitted during the inspection. A detailed QAP has to be submitted indicating the stages of inspection and type of inspection.

- 4. Sample:** All items shall be fabricated as per the samples provided by CSL. Sample to be collected by the contractor from CKSRU at their own cost. Identical parts shall be fabricated ensuring dimensional similarity such a way that it's easy to inter-change while using

5. Location of Supply:

Hooghly Cochin Shipyard Limited
Satyen Bose Road, P.O. Danesh Sk. Lane,
Nazirgunge, Howrah-711109,
West Bengal, India

- 6. Refer Annexure-12 for detailed drawing / description.**

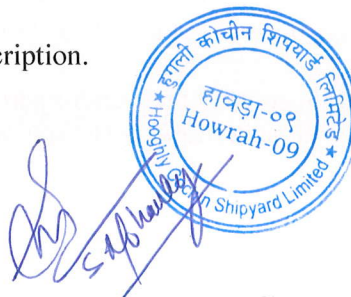

C. Terms and Conditions

1. Tenderers are to carefully go through the terms and conditions and the technical specification of the items for which offers are called for.
2. Offers are to be furnished in duplicate and should be free from overwriting. Corrections and additions, if any, must be attested. Incomplete/ambiguous offers are likely to be rejected.
3. The tender documents can be downloaded from HCSL/ CSL website <http://hooghlycsl.com> or www.cochinshipyard.com. The tender documents are available on above mentioned link. All corrigenda, addenda, amendments and clarifications to this tender will be hosted in the website www.cochinshipyard.com or <http://www.eprocure.gov.in> and not in the newspaper. Bidders shall keep themselves updated with all such developments till the last date and time of submission of tender.
4. Offer shall be submitted in the prescribed form in the 'HCSL Tender Box' located at Hooghly Cochin Shipyard Limited, Satyen Bose Road, P.O. Danesh Sk. Lane, Nazirgunge, Howrah-711109, West Bengal, India, and has to be addressed to The Assistant General Manager (Procurement & Planning-HCSL), Satyen Bose Road, P.O. Danesh Sk. Lane, Nazirgunge, Howrah-711109.
5. All applicable taxes, duties, etc at HCSL Nazirgunge, should be included in the rate quoted, unless specified otherwise. HCSL reserves the right for the deduction of taxes and duties as applicable from the bill or invoice.
6. GST should be indicated separately and shall be paid extra as per Govt. of India rules.
7. Contractors to note that no advance payment will be made by HCSL against work order issued.
8. The bidders may contact below for undertaking site visit and in case of any clarifications regarding scope of work.

Shri Siddharth Mohanty, Manager- Marine & Central Services, HCSL
email id: siddharth.mohanty@hooghlycsl.com
mob: +91-7489858690

9. No enhancement of rate for whatever cause will be allowed once the offer is accepted and an order is placed.
10. Individual lowest rate will not be taken for considering L1. Being a work package the total amount for all line items/services excluding GST will be the criteria for considering L1 bidder.
11. All relevant clauses of general conditions of contract prevalent in HCSL will be applicable to this contract also. HSE guidelines issued by HCSL from time to time shall be followed by the firm
12. Corrections and additions if any in the rate quoted must be attested / duly signed by the bidder. In the case of error in multiplication / addition in amount calculated, the unit rate quoted will be considered as correct and the amount will be calculated accordingly. Conditional rebates & discounts, incomplete/ambiguous offers are likely to be rejected.
13. The contract shall be on a principal-to-principal basis and it will not create any employer, employee relationship between HCSL and the firm or its employees/personnel. This contract shall also not be deemed to create any partnership, joint venture or any association between HCSL and the firm.
14. During the evaluation of tender AGM (Planning & Procurement-HCSL) may at his discretion ask the bidders for clarification in writing. Response for clarification shall be given in writing and no change in prices or substance of the bid shall be sought, offered or permitted. No post bid clarification on the initiative of the bidder will be entertained.
15. HCSL reserves the right to award the contract to one or more firms or may split the scope of work, depending upon the actual necessity, as deemed fit.
16. HCSL reserves the right to reject any or all the offers without assigning any reason whatsoever.
17. The rates agreed upon as per quotation remain firm and fixed and will not be changed till conclusion of contract including extended period, if any.
18. The acceptance of a tender will rest with AGM (Planning & Procurement-HCSL) who does not bind himself to accept the lowest tender and reserves the right to himself the authority to reject any or all of the tenders received without assigning any reason.
19. **Quoting for all serials is mandatory. Partially quoting for few serials shall result in rejection of the bid**
20. Any type of Intermediary/any type of agency/third party on behalf of a firm or a group of firms are not eligible to participate in tender. Firm shall directly submit bid for a contractual agreement with HCSL directly.
21. The firm should not subcontract the work or part of the work to any other agency if awarded the contract
22. Amendment if any will be notified on HCSL/CSL website. The bidders are requested to keep themselves

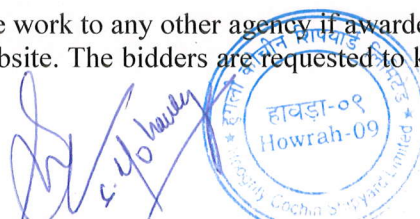

informed of the development by visiting HCSL/CSL website www.cochinshipyard.com and www.hooghlycsl.com. Such amendments shall be binding upon them.

23. Transportation and Transit insurance shall be in the scope of supplier and unit prices quoted are to be inclusive of the same.
24. Packing Material should be eco-friendly.
25. Supplier should follow the statutory requirements of products offered.
26. Products supplied shall be nontoxic and harmless to health. In the case of toxic materials Material Safety Datasheet may be furnished along with the material.
27. After submission of tender, no unsolicited correspondence will be entertained.
28. Hooghly Cochin Shipyard Limited does not bind itself to accept the lowest or any tender but reserves to itself the right to reject any or all or a part of any tender at its discretion.

D. Validity of offer: The offer should be valid for a minimum period of four (4) months from the date of submission of an offer.

E. Delivery Period: All the items as per the scope of work shall be delivered as per the tender conditions within 16 Weeks from the date of acceptance of order.

F. Payment terms:

1. Payment will be released after completion of supply of all items as per the Purchase Order and final acceptance by Officer-in-Charge after necessary deduction including Security Deposit if any. Original tax invoice should contain GST number of both parties and submit in triplicate.
2. Contractor shall indicate details like PAN, GST details etc. required for processing payment. Payments will be made through NEFT/RTGS/Cheque mode and necessary details shall be furnished by the contractor.
3. HCSL reserves the right for the deduction of taxes and duties as applicable from the bill or invoice
4. The invoice to be raised on Officer in-charge, Hooghly Cochin Shipyard Limited, Satyen Bose Road, P.O. Danesh Sk. Lane, Nazirgunge, Howrah-711109, West Bengal, India.
5. Payment will be released tentatively within 30 days from the date of submission of bill duly certified by the authorized HCSL representative. Delay of accepted bills will lead to delay in processing of payment.
6. The firm/bidder winning the contract shall sign an agreement with Hooghly Cochin Shipyard Ltd for "Fall Clause". Accordingly, during the contract period the firm/bidder cannot offer the item/s to anyone else at rates lower than the rates quoted, or the same lowest rate shall be applicable to the contract with HCSL.
7. Manufacturer's name, their trademark and brand, if any, should invariably be mentioned and illustrative leaflets giving technical particulars etc., should be attached to the offer.
8. Materials offered shall conform to HCSL specifications and drawings.
9. Samples are to be supplied free of cost in the event of requirement by HCSL. The detailed working drawing, if called for, is also to be furnished for approval before commencement of manufacture.
10. The quantities to be purchased may vary according to actual requirement at the time of placing orders.

G. Cost of Tender and EMD (Earnest Money Deposit):

1. **Cost of Tender form: NIL**
2. Tenderers shall deposit an amount of **Rs 100000/-(One Lakhs only)** as Earnest Money Deposit (EMD) along with the tender.
3. The EMD can be remitted in the form of Demand Draft (DD) / Banker's Cheque / Fixed Deposit Receipt (FDR)/ Bank Guarantee drawn in favor of "Hooghly Cochin Shipyard Limited" payable at Kolkata and shall be valid for a period of 6 (Six) months from the due date of opening of Techno-commercial Bids from any Nationalized/ Scheduled Bank or paid online through e-gateway of -

**UNION BANK OF INDIA
SHIBPUR-HOWRAH BRANCH
ACCOUNT NO: 756905010000104
IFSC CODE: UBIN0575691**

4. EMD furnished by all contractors except the lowest tenderer will be released after issuing work order and submission of SD and its acceptance by the contractor to whom the work is awarded.

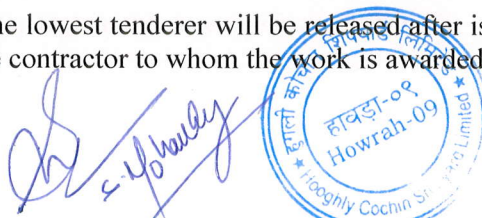

5. EMD of the successful tenderer will be refunded after remittance of the security deposit and acceptance of the order.
6. The Earnest Money Deposit (EMD) may be forfeited if:
 - i) The bidder withdraws, amends, impairs, or derogates from the tender or agreed conditions in any respect within the period of validity of their offer.
 - ii) Non-acceptance of work order.
 - iii) Bidder after accepting the work order fails to provide services.
7. Micro and Small Enterprises (MSEs) as defined in MSE Procurement Policy issued by Department of Micro, Small and Medium Enterprises (MSME) or are registered with the Central Purchase Organisation or the concerned Ministry or Department are exempted from submission of EMD.

H. Security Deposit

1. Contractor shall give security deposit in the form of Bank Guarantee for 5% order value within 15 days after receiving of Work Order.
2. Security Deposit will be returned one (1) month after successful completion of the contract.
3. No interest shall be payable on SD for the period of its pendency.
4. SD will be forfeited where the contractor fails to meet the contractual obligations.
5. Bidders with valid registration under NSIC/MSE category are also entitled for all privileges, concessions, relaxations etc. stipulated by relevant Govt. orders in this regard.
6. Bidders with valid registration under NSIC/MSME category are also entitled for all privileges, concessions, relaxations etc. stipulated by relevant Govt. orders in this regard.

I. Indemnity clause

The firm shall indemnify HCSL and keep harmless against any or all claims, liabilities, damages, losses, costs, charges, expenses, proceedings and actions of any nature whatsoever made or instituted against HCSL directly or indirectly by reason of:

- i) Any wrongful, incorrect, dishonest, criminal, fraudulent or negligent work, misfeasance, disregard of duties by personnel of the firm; and/or
- ii) Any theft, robbery, fraud or wrongful act or omission by personnel of the firm.

J. Jurisdiction: Any disputes or differences arising under, out of, or in connection with the contract shall be subject to the exclusive jurisdiction of courts at Kolkata, West Bengal, India.

K. Force Majeure Condition: Should failure in performance of the contract or part thereof arise from war insurrection, restraint imposed by Government, Act of Legislature or other Statutory Authority or illegal strike, riot, legal lock-out, flood, fire, explosion, act of God or any inevitable or unforeseen event beyond human control which may be construed as reasonable ground for an extension of time, HCSL may allow such additional time as is mutually agreed to be justified by the circumstances of the case. The occurrence/cessation of force majeure situation is to be informed with documentary evidence within 15 days from the date of occurrence/cessation.

L. Guarantee Period: The goods supplied shall be guaranteed for workmanship and satisfactory performance for a period of 12 months from the date of receipt of the materials at HCSL and acceptance of the materials after receipt at HCSL. Supplier should replace the defective materials without cost implication to HCSL immediately after intimation of any such defects noticed during the Guarantee period.

M. Liquidated Damage: In case any delay in completion period or in the Supply of ordered materials beyond the stipulated completion period / delivery period, the contractor has to pay Liquidated Damage (LD), a sum equivalent to ½% (half percentage) of the order value per week or part of the week subjected to maximum of 10 % of the order value.

N. Risk Purchase: If the contractor fails to commence the work in time, as per the terms in work order or violate any other terms & conditions of work order, HCSL shall have the following rights.

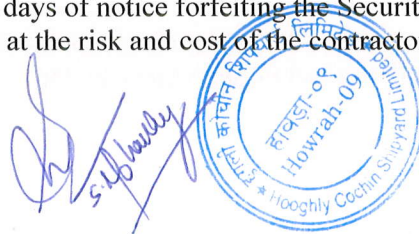

- a) To terminate the contract within 15 days of notice forfeiting the Security deposit.
- b) To initiate alternative arrangements at the risk and cost of the contractor.



If the firm's performance is found not satisfactory with regard to the progress of work, quality, and time factor, labour dispute with their workers, poor safety record, and contract shall be terminated with 15 day notice and no claim whatsoever will be entertained in this regard from the firm

O. Instructions to bidder for submission of quote

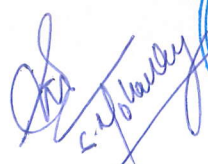
1. Sealed tenders in Single cover system (Prequalification cum Technical and Price Bid) addressed to **The AGM (Planning & Procurement)** shall be dropped in the HCSL tender box or by courier to **Hooghly Cochin Shipyard Ltd (HCSL), Satyen Bose Road, DaneshSk Lane (PO), Nazirgunge, Howrah, West Bengal, PIN -711109 before the due date and time.**
2. Techno Commercial part should contain following details.
 - Stamped and signed copy of all pages of tender document and corrigenda (if any) with all supporting document
 - Check list as per **Annexure-3**
 - Vender details as per **Annexure-4**
 - NEFT Mandate Form as per **Annexure-5**
 - List of deviation as per **Annexure-6**
 - Form of Bank Guarantee towards EMD as per **Annexure-7**
 - Format of security Deposit as per **Annexure-8**
 - Form of Self Declaration as per **Annexure-9**
 - Form of Legal Cases as per **Annexure-10**
 - Undertaking as per **Annexure-11**
 - Reference Drawings as per **Annexure-12**
 - Signed copy of un-priced Price bid (**Annexure-2**) (Price bid without price & with percentage of taxes & duties and details like quoted/Nil/Included need to be mentioned for each line item)
3. Cost of Tender and EMD to submit along with Tender documents otherwise Bid will be rejected.
4. In Price Part as per Price Bid format (Annexure 2) should be signed and stamped and separately uploaded only in the designated space. If Price bid is merged with technical documents, it directly leads to rejection of offer.
5. The Techno-commercial part alone will be opened initially on the due date of tender. The price part will be opened only after evaluation of the Techno commercial part. Firms will be intimated the date of opening of the price part, whose Techno-commercial bid is acceptable, in due course. **Tenderers shall not be allowed to attend the Techno commercial bid opening.**
6. After submission of quotation / price opening, no unsolicited correspondence will be entertained.
7. Check lists, technical & commercial, duly filled & signed should be submitted along with Part-I "Techno-Commercial" bid. Non-receipt of this document may lead to rejection of the offer.
8. Offers should be clear and unambiguous. Incomplete/ambiguous offers are likely to be rejected.
9. Bid Submission shall include Amendment / corrigendum / response to pre bid query duly signed and accept (if any).
10. Price part of technically acceptable offers only will be considered for opening.
11. The bidder is expected and deemed to have read, understood and agreed to all instructions, forms, terms and specifications etc. in the tender document while bidding.
12. Failure to furnish all information required or False/ambiguous information or submission of bid not substantially responsive to the bidding documents in every respect will be at the Bidder's risk and may result in rejection of the bid.
13. All pages of the offer (including all supporting documents/attachments) should be signed by the authorized signatory of the bidder in acceptance of tender conditions. Scanned copy of the same may be attached in the bid. Unsigned and unstamped bids shall be summarily rejected.
14. All documents, instructions, catalogues, brochures, pamphlets, design data, norms and calculations, drawings, operation, maintenance and safety manuals, reports, labels on deliveries and any other data shall be in English language.

PRICE BID FORMAT

Tender No: HCSSL/OPS/YS/TEN/026/2024-25, Dated 25-06-2024

Tender Description: SUPPLY OF STAGING MATERIALS FOR HCSSL, NAZIRGUNGE UNIT, HOWRAH, W.B.

Sl. No.	Item	Description	Qty (A)	UOM	Unit Rate (B)	Total Cost (C= A*B)
1	VERTICAL / STANDARD OF LENGTH 3000 MM	<p>Verticals of length 3000mm shall be made of 40 NB Heavy Class continuous welded steel tubes conforming to IS: 1239, Heavy Class or equivalent and have 5 mm thick sockets welded at 50 cm centre for fixing Transoms or Ledgers. Each vertical shall have specially designed captive expanding joint (hollow wedges of 5 mm thickness) working on wedge principles for connecting the vertical together.</p> <p>Verticals are to be applied with one (1) coat of Red Oxide primer and two (2) coats of synthetic enamel paint of Royal Blue colour. Surface preparation by pickling/ phosphating to be carried out. Pickling/ phosphating are to done as per IS standard. To ensure quality, inspection and testing procedure as per IS-3618 will be followed. The procedure & method of pickling / phosphating is to be submitted by the supplier along with Bid.</p>	1000	Nos		
2	HORIZONTALS / LEDGER OF LENGTH 2445 MM	<p>Ledgers shall be fabricated with Welded Steel Tubes 40 NB Light Class of the length 2445mm. Either ends of the ledgers shall have captive wedges of 8 mm thick to facilitate connection to the verticals.</p> <p>Ledgers are to be applied with one (1) coat of Red Oxide primer and two (2) coats of synthetic enamel paint of Royal Blue colour. Surface preparation by pickling/ phosphating to be carried out. Pickling and phosphating are to done as per IS standard. To ensure quality, inspection and testing procedure as per IS-3618 will be followed. The procedure & method of pickling / phosphating is to be submitted by the supplier along with Bid.</p>	2000	Nos		

3	HORIZONTALS / LEDGER OF LENGTH 1195 MM	Ledgers to be fabricated with Welded Steel Tubes of 40 mm NB Light Class. The length of a ledger is 1,195 mm and either ends of the ledgers are having captive wedges of 8 mm thick to facilitate connection to the verticals. Ledgers are to be applied with one (1) coat of Red Oxide primer and two (2) coats of synthetic enamel paint of Royal Blue colour. Surface preparation by pickling/phosphating to be carried out. Pickling/phosphating are to be done as per IS standard. To ensure quality, inspection and testing procedure as per IS-3618 will be followed. The procedure & method of pickling / phosphating is to be submitted by the supplier along with Bid.	120	Nos	
5	TRANSOM FOR STAGING 1,195 MM LONG	Transoms shall be fabricated with 50x50x6 mm MS Angles. The length of the transom shall be 1195mm. Either ends of the transoms shall have captive wedges of 8 mm thick to facilitate connection to the verticals. Transoms are to be applied with one (1) coat of Red Oxide primer and two (2) coats of synthetic enamel paint of Royal Blue colour. Surface preparation by pickling/phosphate to be carried out. Pickling/phosphate are to be done as per IS standard. To ensure quality, inspection and testing procedure as per IS-3618 will be followed. The procedure & method of pickling / phosphate is to be submitted by the supplier along with Bid.	1000	Nos	
6	HOT DIP GALVANIZED ADJUSTABLE BASE JACK	Adj. base jacks shall have 150x150x6mm Base plate with dia 36 mm threaded round bars along with adjustable nut. The adjustable base jacks have to provide 500mm of thread adjustment. Base plate has to be hot dip galvanized to a min 400 GSM / 60 micron (whichever is higher) as per IS 4736 and stud has to be electroplated as per IS1573 Gr2.	200	Nos	
7	SWIVEL CLAMP (40 MM x 40 MM, MS ELECTROPLATED)	Any reputed Indian Standard brand and are to electroplated as per IS 1573 Gr2.	200	Nos	
8	RIGHT ANGLE CLAMPS (MS ELECTROPLATED)		200	Nos	
9	BEAM CLAMP (MS ELECTROPLATED)		200	Nos	

10	HOT DIP GALVANIZED STAGING BOARD (50X235X2460 MM)	Staging boards shall be made out of MS Sheet as per IS: 513:2008 of thickness 16-gauge, sectional size 50x235 mm and the length of 2460 mm. Board width shall be 230-235mm to ensure reasonable gap between the boards when laid. The bottom edge of the boards is to be bent about 25 mm towards inside. Steel boards are to be press bent with anti-skid dimples on the top side of the boards. Three stiffeners (03) shall be provided under the boards at equal spacing and enclosing both ends. Post manufacturing each staging boards has to be hot dip galvanized as per IS:4736 and a minimum & uniform zinc deposition (400 GSM/ 60 micron) as per IS:4736 has to be ensured.	2000	Nos	
11	HOT DIP GALVANIZED STAGING BOARD (50X235X1200 MM)	Staging Boards shall be made out of MS Sheets as per IS:513:2008 of thickness 16-gauge, sectional size of 50 x 235 mm and length of 1,200 mm. Board width shall be 230-235mm to ensure reasonable gap between the boards when laid. The bottom edge of the boards is to be bent about 25 mm towards inside. Steel Boards are to be press bent with anti-skid dimples on top of the boards. One (1) stiffener shall be provided under the board and enclosing both ends. Post manufacturing, each staging board has to be hot dip galvanized as per IS 4736 and a minimum & uniform Zinc deposition of 400 GSM / 60 microns (whichever is higher) has to be ensured	150	Nos	
12	HOT DIP GALVANIZED Monkey Ladder(length-3mtr)	Staging Ladder 3,000 mm long (25 NB 'B' Class Pipes) with 10 Nos. rungs (20 NB 'B' Class pipes) and hooks as per sketch. Post manufacturing, each staging ladder has to be hot dip galvanized as per IS 4736 and a minimum & uniform Zinc deposition as per IS 4736 has to be ensured.	200	Nos	
15	Castrol wheel	8" cast-iron wheel with a PU overlay that is 2 inches wide and over an inch of rubber covering the iron caster wheel with ball bearings in the pivot mechanism to handle high loading. Double zerker grease fittings. Double lock to maintain rock solidness. The stem of the caster wheel should be 38mm OD with an 8" length Threaded with Wing nut to adjust the height.	25	Nos	
16	40 NB PIPE (C CLASS) 6,000MM LONG	As per IS 1239, Pipes are to be applied with one (1) coat of Red Oxide primer and two (2) coats of synthetic enamel paint of Royal Blue colour.	100	Nos	
Total Cost of material Excl GST			₹		
GST @18%			₹		
Total Cost of material incl GST (in figures)			₹		

Total Cost of material incl GST (in words)

Notes:

1. Individual lowest rate will not be taken for considering L1. Being a work package the total amount for all line items/services excluding GST will be the criteria for considering L1 bidder.
2. All applicable taxes, duties, etc at HCSL Nazirgunge, should be included in the rate quoted, unless specified otherwise. HCSL reserves the right for the deduction of taxes and duties as applicable from the bill or invoice.
3. Quoting for all serials is mandatory. Partially quoting for few serials shall result in rejection of the bid.
4. Rate agreed upon as per quotation shall remain firm and fixed and will not be changed till conclusion of contract.
5. Bidders shall quote total amount in figures and in words. Corrections and additions if any must be attested/ duly signed by the bidder. In the case of error in multiplication/addition in amount calculated, unit rate quoted will be considered as correct and the amount will be calculated accordingly. Conditional rebates & discounts, incomplete/ambiguous offers are likely to be rejected.

Date:

Signature of authorized personnel:

Name of firm or authorized signatory:

Designation:

Contact No:

CHECKLIST

TECHNO-COMMERCIAL CHECK LIST				
SL. NO.	DESCRIPTION	COMPLIANCE		REMARKS
		YES	NO	
1	Submission of Tender in two (2) parts – Techno-commercial & Price			
2	Delivery date confirmation to delivery schedule			
3	EMD submitted with the Bid			
4	Validity of offer – Four (4) months			
5	Payment Terms			
6	ITR, Balance Sheets, Profit & loss statement for FY 2020-21, 2021-22 & 2022-23 submitted with the Bid			
7	The Prices offered should remain firm till the completion of the contract, in case the purchase order is placed with you.			
8	A copy of price offers without price to be included in the techno- commercial offer. Please confirm.			
9	Have you considered Taxes, duties, levies, packing & forwarding etc., if any, in the offer?			
10	Compliance with Pre-qualification criterion			
11	Disputes in connection with contract subject to jurisdiction of courts at Kolkata India.			
12	Termination of contract/Risk purchase as per relevant clause in the General terms of enquiry.			
13	You should furnish appropriate certificate/paper. (Refer Annexure 2)			
14	Confirm all other terms and conditions of enquiry are			
15	MSME/NSIC, if yes document required along with technical bid, in relevant sector			
16	PAN, GST certificate submitted with the Bid			
17	Vendor details to be submitted as per Annexure 6			
18	Contractor should have annual turnover at least Rs. 14 lakhs in each financial year during the last three preceding years, if yes supporting document to be submitted along with technical bid			
19	You have read & understood all the Terms & Conditions of the tender			

VENDOR DETAIL

1	Name of the Contractor/Firm	
2	Registered office Address of Company/Firm	
3	Local office address at Kolkata/Howrah (if held):	
4	Telephone No./Fax No./Mobile No	
5	E-mail address	
6	Names of the contact person & designation	(i)
		(ii)
		(iii)
7	Name & contact detail of the concerned person who is dealing with this tender	Name:
		Contact number:
8	Type of Entity - Proprietorship/ Partnership firm/ Company/ NSIC/ MSME Category etc.	
	<i>(Please attach registration certificate of Firm/Partnership agreement/proprietorship documents)</i>	
9	PAN Card Number	
	GST Registration Number	
	<i>(GST certificate to submitted along with the technical bid)</i>	
	EPF Registration No.	
	<i>(EPF registration certificate to be submitted along with the technical bid)</i>	
	<i>Note: In case firm does not have EPF registration reasons thereof to be indicated</i>	
	ESI Registration No. (If applicable)	
	<i>(ESI registration certificate to be submitted along with the technical bid). Note: In case firm does not have ESI registration reasons thereof to be indicated</i>	
Copy of License if applicable		
10	EMD Details (DD No. Name of Bank)	
11	Whether the agency has been blacklisted/de barred or given tender holiday or contract terminated before expiry of the contract period by any govt. autonomous bodies/organizations where contractor	Yes/No
		(Please tick as applicable)
		If yes, please furnish details on a separate sheet

Certified that the above information is true to the best of our belief and information.

Place:

Date:

Signature of Contractor/Authorized signature of firm/agency:

Name of Contractor or authorized signatory of firm/agency:

Designation:

Sign & seal of contractor

NEFT MANDATE FORM

(ON THE LETTER HEAD OF THE COMPANY)

Electronic Payment Mandate Form

(Mandate for receiving payments through RTGS/NEFT Hooghly Cochin Shipyard Ltd)

- 1) Vendor Name
 - 2) Vendor Address with Phone No
 - 3) Vendor Code
 - 4) Permanent Account No. (PAN)
 - 5) Particulars of Bank Account
 - a. Name of the Bank
 -
 - b. Name of the Branch
 -
 - c. Branch Code
 - d. NEFT Code of the Bank
 - e. City Name
 - f. Branch Location
 - g. Branch Telephone No.
 - h. Bank IFSC Code
 - i. 9-Digit MICR Code
- (Where MICR is starting with "0". Please take the correct code from your bank for proper identification of city, bank, branch)**
- i. Type of the Account (S.B Current or Cash Credit) with code (010/011/013)
 - j. Account Number (as appearing on the cheque book)
 - 6) Email Address of Vendor
 - 7) Date of Effect of RTGS/NEFT in your Bank

(Please enclose a cancelled un-signed cheque leaf to enable us to verify the details mentioned above)

We hereby declare that the particulars given above are correct and complete. If the transaction is delayed or lost because of incomplete or incorrect information, we would not hold the company responsible.

(.....)
Signature of Employee

Bank Certificate

We certify that _____ has an Account No. _____ with us
and we confirm that the details given above are correct as per our records.

Date:

Place:

(.....)
Authorized official of Bank

Note: Please enclose a cancelled cheque

COMPLIANCE STATEMENT- SPECIAL INSTRUCTIONS FOR TENDERERS AND TECHNICAL SPECIFICATION	PAGE 1 OF 1
--	-------------

Tender Name: **SUPPLY OF STAGING MATERIALS FOR IICSL, NAZIRGUNGE UNIT, HOWRAH, W.B.**

TENDER NO: **HCSL/OPS/YS/TEN/026/2024-25, Dated 25-06-2024.**

We hereby confirm and truly declare that our Offer / Bid No.datedis in full compliance with the documents issued against the Tender No. _____dated _____, except for the deviations listed below:

LIST OF DEVIATIONS (HCSL reserves the right to reject offers with deviations)

Sl.No.	Description / Tender Reference	Reasons for Deviation

Name of tenderer:

Date: _____ Name & Designation _____ Seal & Signature _____
(Company Seal)

Note: Mention “Nil Deviation” if nothing, otherwise provide the same in above column

Form of bank Guarantee towards EMD

(On stamp paper of value Rs. 200/-)

This deed of GURANTEE made on day ofTwo thousand Eighteen between HCSL on the one part and (Name and address of the bank) of the other part is as follows: -

In consideration of the HCSL having allowed M/s..... (Hereinafter referred to as 'the Contractor') to submit Tender No..... to them without Earnest Money according to the conditions of such Tender Notification.

We..... (here enter the name of 'the Bank') a Company incorporated under theAct and having its registered office at(hereinafter referred to as 'the bank') undertake to pay to HCSL on demand at Kolkata the sum of money payable as Earnest Money in respect of the Tender No.....made by the Contractor, in case the Contractor withdraws the tender before the date of firmness stipulated or when the tender is accepted by or on behalf of the HCSL the Contractor makes default in furnishing the Security Deposit or in entering into an agreement as required by the HCSL or otherwise commits any breach of the terms and conditions of the tender.

We,Bank Guarantee to pay the amount due and payable under this guarantee without any demur merely on demand from the HCSL. Any such demand made on the Bank shall be conclusive as regards the amount due and payable by the Bank under this guarantee. The liability of the surety shall be restricted to Rs(Rs.....only).

This guarantee shall not be avoided, released or affected by any variation in the terms of the tender, acceptance or the contract between the Contractor and the HCSL or any neglect indulgence or forbearance by the HCSL.

This guarantee shall remain in full force and effect during the period that would be taken for the finalization of the tender and till the HCSL certifies that the terms and conditions of the said tender have been fully and properly carried out by the Contractor and accordingly discharges this guarantee or for Six Months from the date of issue of this guarantee whichever is earlier. A notice of the claim under this guarantee may be served on the Bank within Six Months after the said period in which case the same shall be enforceable against the Bank notwithstanding the fact that the same is enforced after the expiry of the said period.

The decision of the CEO, HCSL as to whether the occasion or the ground has arisen for the demand of the surety form Bank shall be final. The HCSL shall be at liberty to act as though the Bank were the principal debtor.

We, the said Bank lastly undertake not to revoke this guarantee during its currency except with the previous consent of the HCSL in writing and agree that any change in the constitution of the said contractor or the said Bank shall not discharge our liability hereunder.

In witness whereof we have hereunto set our hand and seal this. day
.....of.....Two thousand and
.....

Place:

Date:

BANK GUARANTEE IN LIEU OF SECURITY DEPOSIT/WARRANTY GUARANTEE**(On Stamp Paper of Value Rs 200/-)****To**

HOOGHLY COCHIN SHIPYARD LTD
 ADMINISTRATIVE BUILDING, HCSL PREMISES
 SATYEN BOSE ROAD, P.O. DANESH SHAIKH LANE
 HOWRAH, WEST BENGAL, INDIA.

WHEREAS (Name & Address of Supplier) (Hereinafter called "**the Supplier**") has undertaken, in pursuance of contract..... No.....Dated:.....to execute (Name of Contract and brief description of works) (hereinafter called "**the Contract**").AND WHEREAS it has been stipulated by **HOOGHLY COCHIN SHIPYARD LTD** (The Buyer - hereinafter called "**HCSL**") in the said contract that the Supplier shall furnish **HCSL** with a Bank Guarantee for the sum specified therein as security for compliance with the Supplier's obligations in accordance with the Contract.

AND WHEREAS we have agreed to give the Supplier such a Bank Guarantee.

NOW THEREFORE we (Name of the Bank) having its Head Office at.....(Address of Head Office) and acting through its branch office at.....(Address of the executing branch) (hereinafter called "**the Bank**") hereby affirm that we are the Guarantor and responsible to **HCSL**, on behalf of the Supplier up to a total of (amount of Guarantee)in words).

We, the bank, hereby irrevocably undertake to pay you any amount not exceeding in total the Guarantee Amount upon receipt by us of your demand in writing accompanied by the following documents:

1. Your signed statement certifying that the Supplier is in breach of his obligation(s) under the Contract and the respect in which the Supplier is in breach.
2. Your signed statement certifying that the Supplier has been given prior written notice by email from you to make good the fore said breach and that the Supplier still failed to fulfill the Contract within 30days of such notice. A copy of such notice given by email to the Supplier shall be attached to the demand for payment.

Any demand for payment should contain your authorized signatures which must be authorized by your bankers or by a notary public.

We, the Bank, further agree that no change or addition to or other modification of the terms of the Contract or of the Works to be performed there under or of any of the Contract documents which may be made between **HCSL** and the Supplier shall in any way release us from any liability under this guarantee, and we hereby waive notice of any such change, addition or modification. We, the Bank, further agree that any change in the constitution of

the said contractor or the said bank shall not discharge our liability hereunder.

Notwithstanding anything contained herein:

1. Our liability under this Bank Guarantee shall not exceed
(.....only).

2. This Bank Guarantee shall be valid up to (date) and

3. We are liable to pay the guaranteed amount or any part thereof under this bank guarantee only and only if
HCSL serve upon us a written claim or demand on or before(validity date).

Any demand for payment under this guarantee must be received by us at this office during working hours on or before the validity date. Should we receive no claim from you by the validity date, our liability to you will cease and the guarantee will definitely become null and void whether returned to us or not.

Yours truly,

Signature and seal of the

guarantor :

Name of Bank:

Address:

Date:

[1]An amount shall be inserted by the Guarantor, representing the percentage of the Contract Price specified in the Contract and denominated in respective Dollars /Indian Rupees/Other Currency.

Self-Declaration to be given by the contractor in Letter head

Bid's Reference No. & Date:

Contractor's Name & Address:

Person to be contacted:

Designation:

Telephone No.:

Fax No.:

Email:

1. We do hereby declare that we have not been debarred/black listed by HCSL or by any of the Public Sector Undertaking or Government department etc.
2. If HCSL finds that, we have been blacklisted/ debarred by any of the Public Sector Undertaking or Government department, and then HCSL can reject the offer or terminate the contract at any point of time. In such case, we are aware that, EMD, security deposit, performance guarantee etc will be forfeited by HCSL. Further we are confirming herewith that, any loss that has happened to HCSL due to this will be compensated by us.

For and on behalf of the firm

(Firms Name & Address)

(Signature of Authorized Signatory)

Name:

Designation

Phone No.:

Seal:

Date:

Place:

(Sample Format)

Details of legal cases pending against the firm for the last five years

SL. NO.	ORGANISATION AGAINST WHOM THE LITIGATION IS INVOLVED	BRIEF DETAILS OF DISPUTE	AMOUNTS INVOLVED (Rs.)	PRESENT STATUS	Remarks

Note: If no Cases exist mention "NIL CASES", otherwise provide the details.

SIGNATURE OF CONTRACTOR

UNDERTAKING

I, Shri in my capacity as Managing Partner / Chairman & Managing Director / Proprietor of M/s do hereby give an undertaking that we shall not subcontract the work or part of work to any other agency if awarded the contract by HCSL.

Signature of authorized signatory of contractor:

Name of authorized signatory of contractor:

Designation:

Address:

Contact No:

REFERENCE DRAWINGS

Encl-1

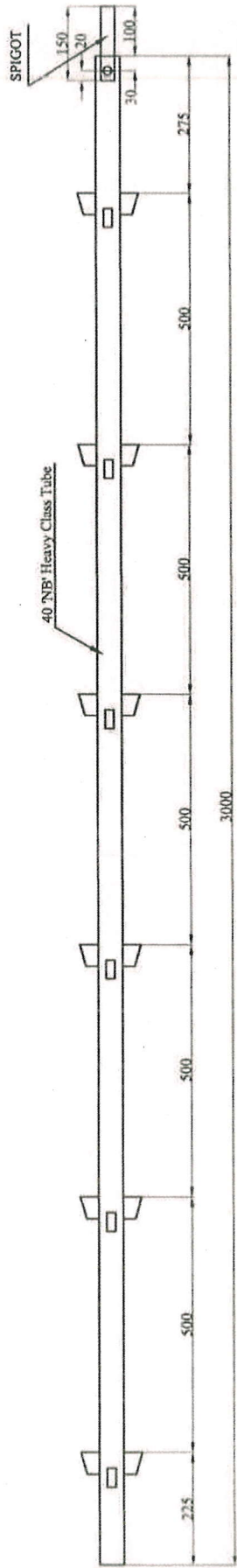

WEDGELOK STANDARD 3000 MM LONG

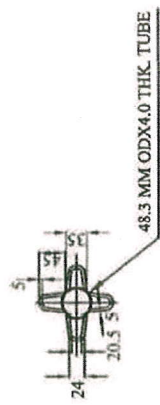

Encl-1

40 NB 'LIGHT' CLASS TUBE

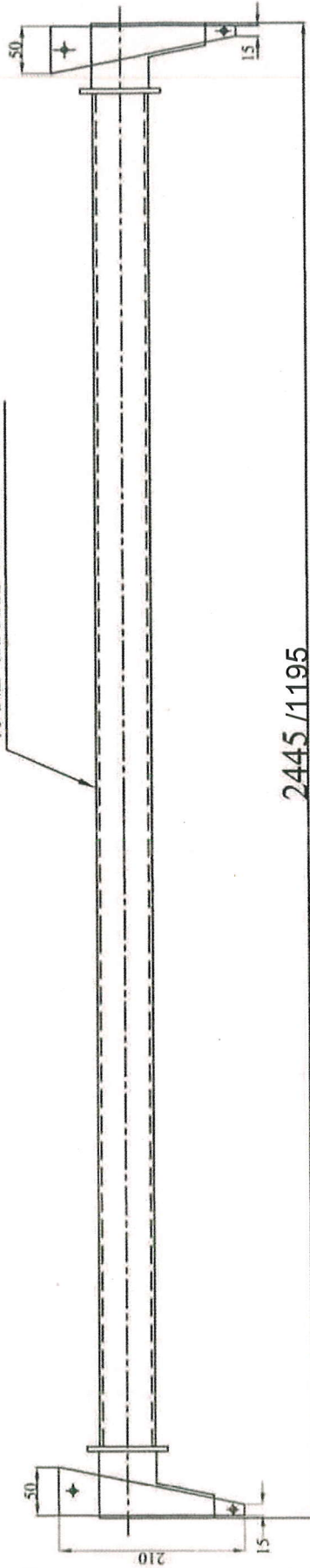

2445 / 1195

WEDGELOCK LEDGER

Encl-1

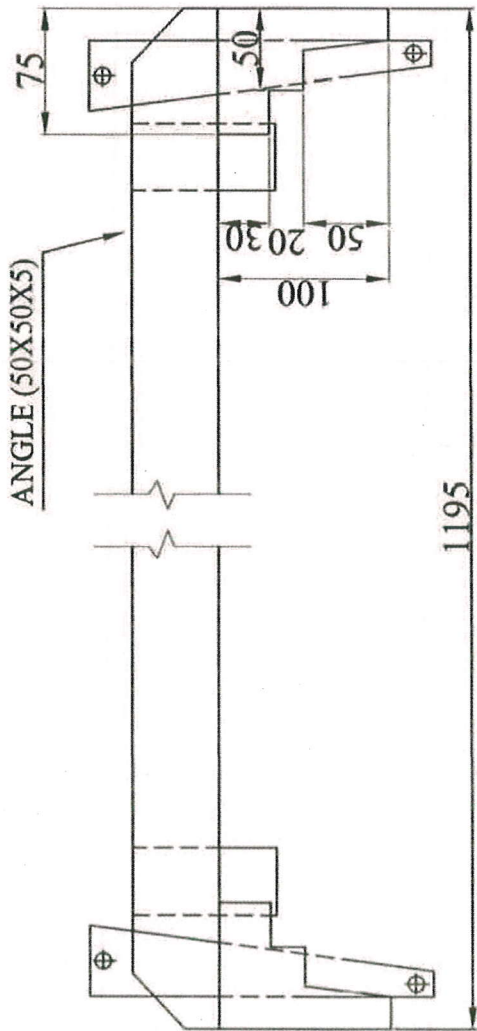

ELEVATION

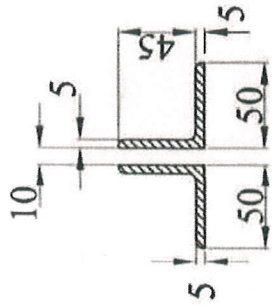

SECTION AT D-D

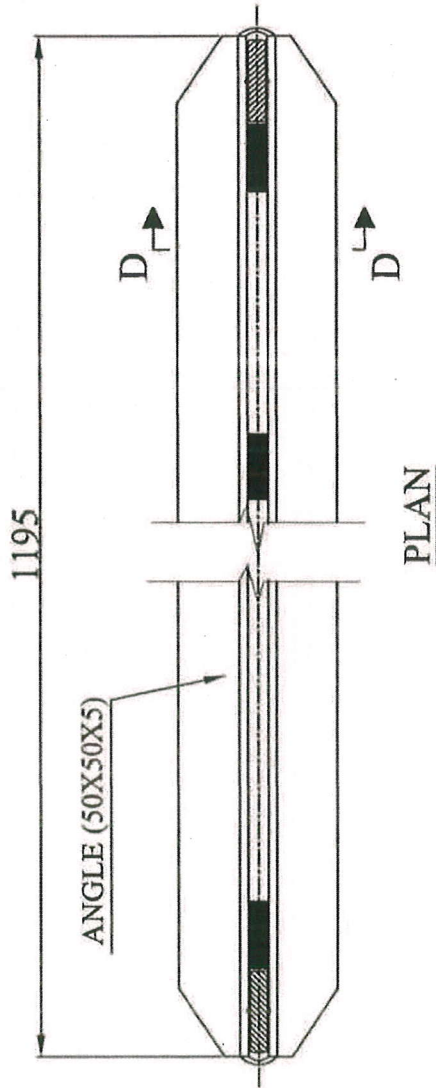

PLAN

Encl-1

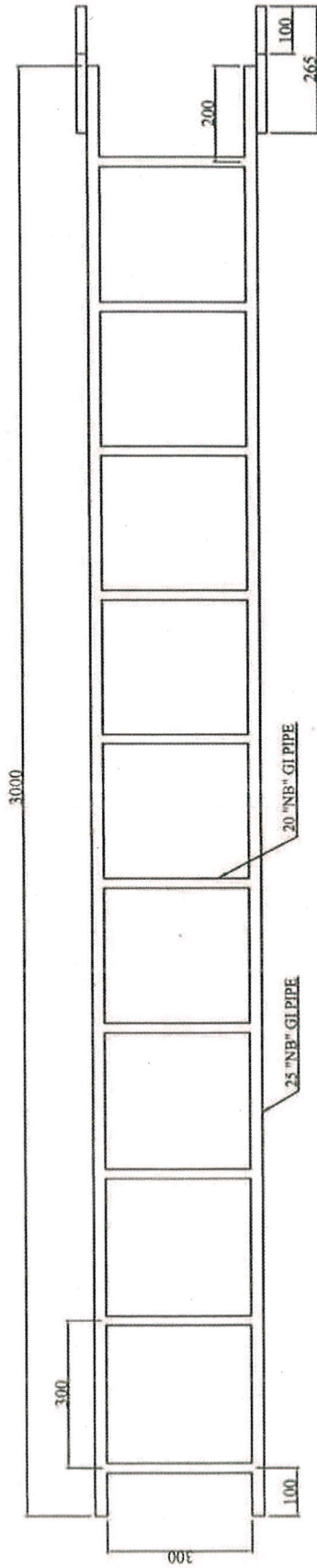
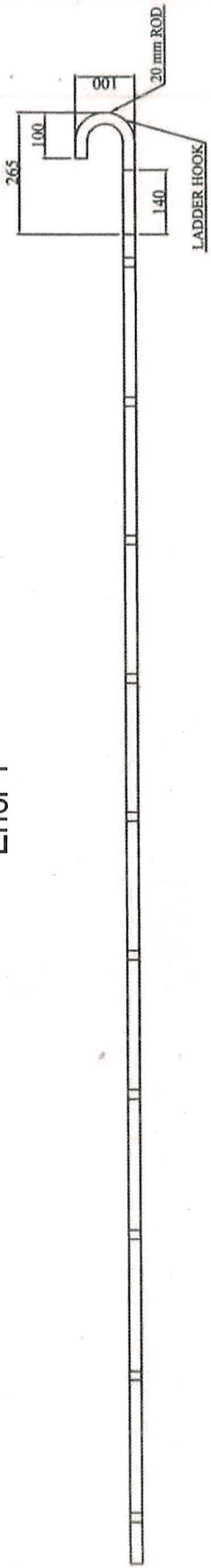

Encl-1

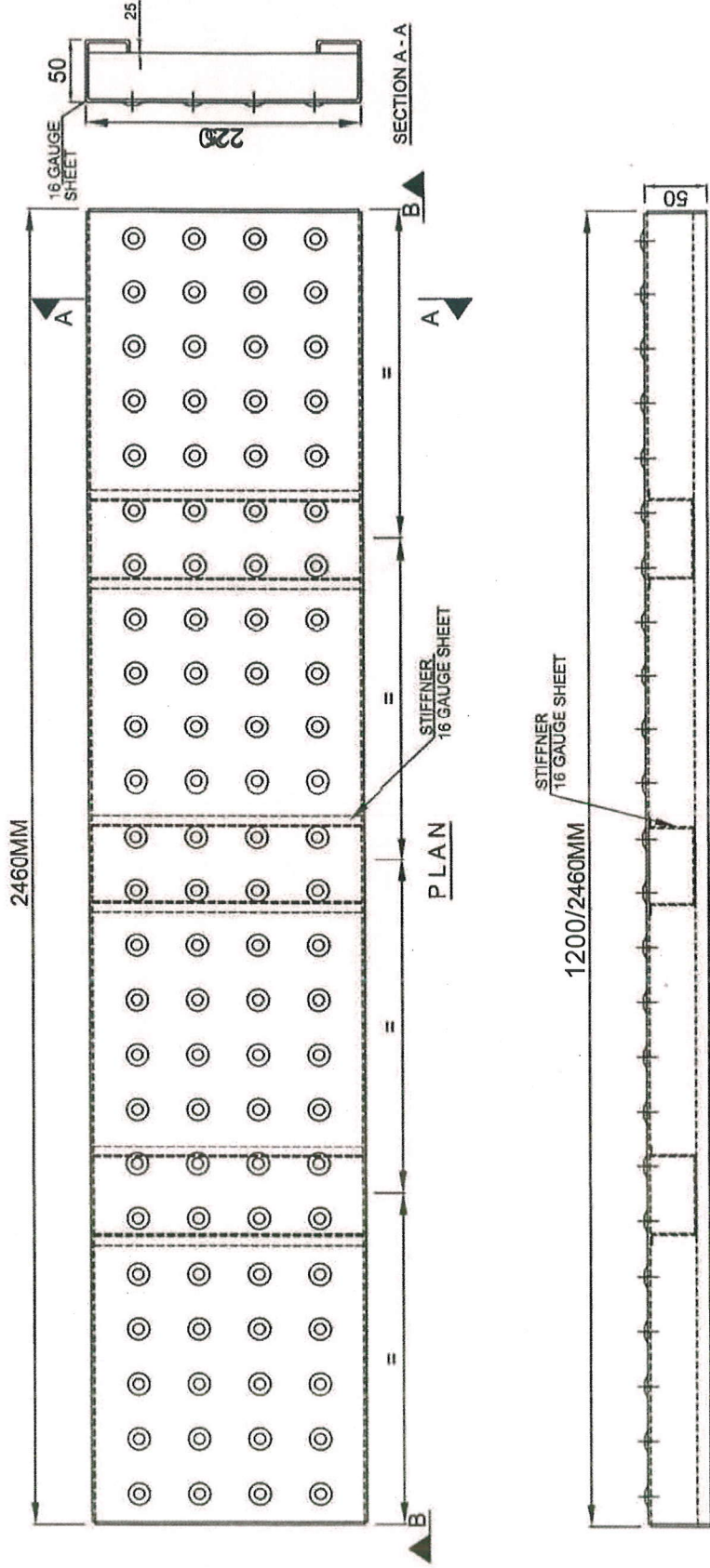

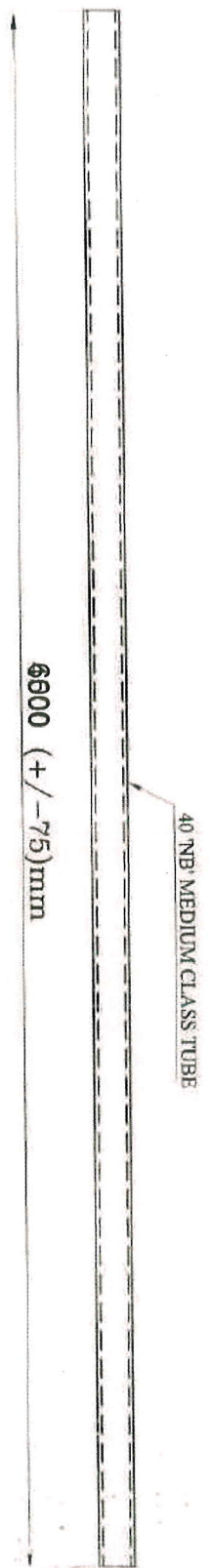

40 NB MEDIUM CLASS TUBE

6000 (+/- 75)mm

DIAGONAL BRACING TUBE

6000 (+/- 75mm)

Base Jack

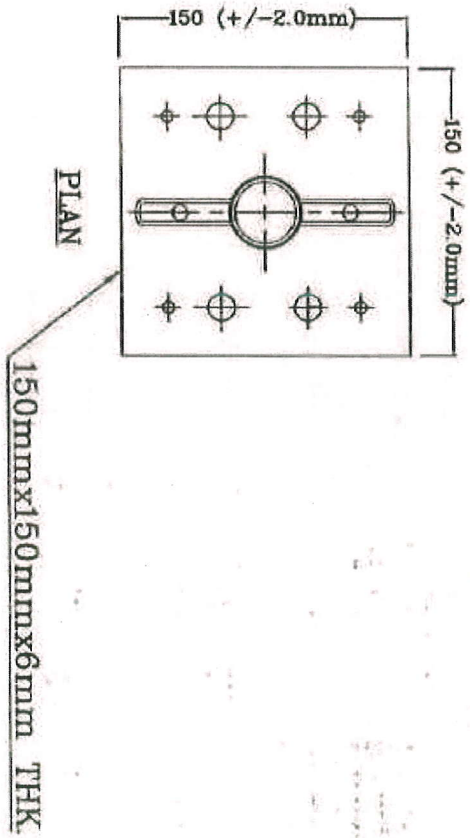
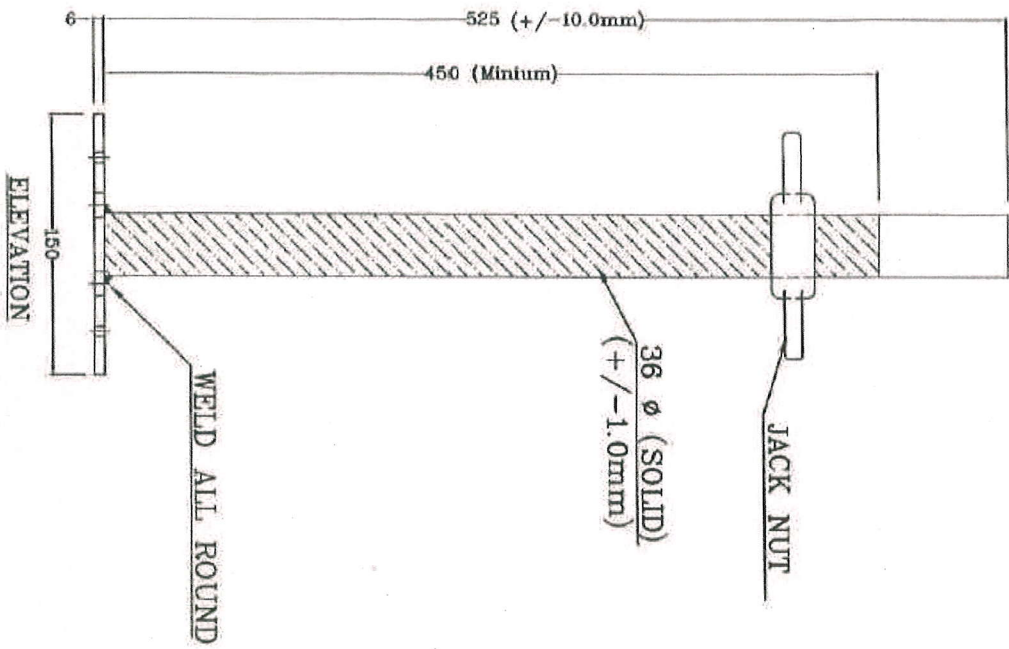

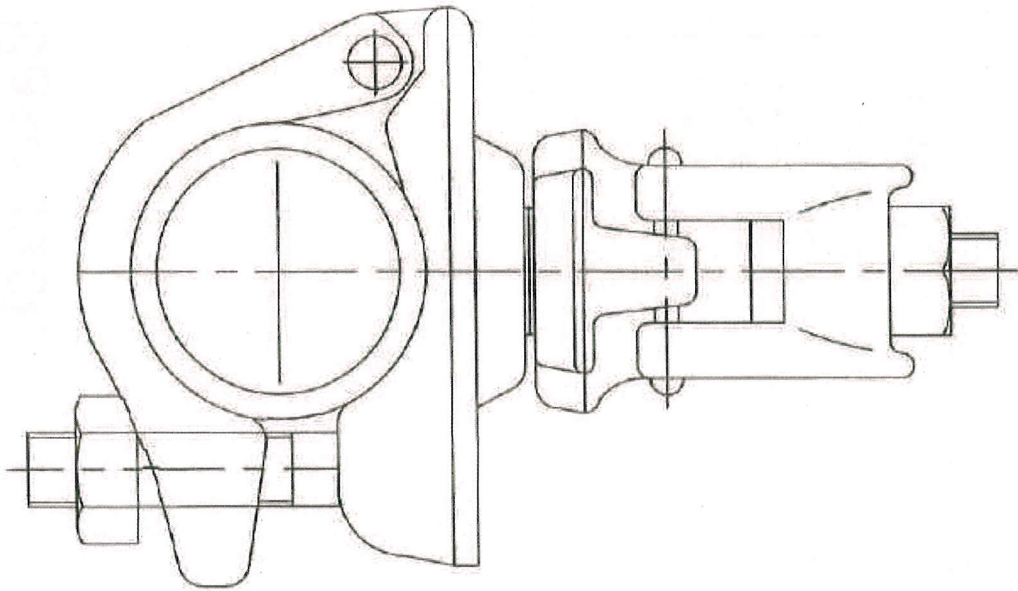

SWIVEL COUPLER (ELECTRO-PLATED)

40 x 40 mm. NB