



हुगली कोचीन शिपयार्ड लिमिटेड
(भारत सरकार का उद्यम)
HOOGLY COCHIN SHIPYARD LIMITED
(A Govt. of India Enterprise)



वसुधैव कुटुम्बकम्
ONE EARTH • ONE FAMILY • ONE FUTURE

Notice Inviting Tender

Tender enquiry notice – Erection, Installation and Assistance for Commissioning of Equipment, Machineries, Steering Gear & Shafting for 50pax Hybrid Catamaran Vessels (06 Nos.) Being Constructed at HCSL

Password protected quotations in the prescribed format from the bidders are invited on behalf of Hooghly Cochin Shipyard Limited (HCSL) from experienced vendors for the under mentioned work, so as to reach the undersigned on or before the date and time mentioned below. Please refer scope of work, general terms and conditions and special terms attached.

Tender No. & date	HCSL/OPS/SB/TEN/021/2024-25 dated 19.06.2024
Scope of work	Erection, Installation and Assistance for Commissioning of Equipment, Machineries, Steering Gear & Shafting for 50pax Hybrid Catamaran Vessels (06 Nos.) being constructed at Hooghly Cochin Shipyard Limited, Nazirgunge Unit, Howrah. (Detailed specification is enclosed separately)
Type of Tender	Two Bid
Cost of tender form	Nil
Earnest Money Deposit (EMD)	Rs. 1,00,000 /- (Rs. One Lac)
Last date & time of receipt of tender	29.06.2024 at 1500 Hrs.
Date & time of opening of technical bid	29.06.2024 at 1530 Hrs. (10 days from the date of floating tender)
Tenure of contract	For each ship the duration will be within 35 Days of site clearance confirmation from HCSL. (5 days for manpower mobilization, 30 days for job completion.)



Registered Office: Administrative Building, HCSL Premises, Satyen Bose Road, P.O. Danesh Shaikh Lane, Nazirgunge, Howrah, West Bengal - 711 109.
☎ +91 (33)-2688 8282 ✉ contact@hooghlycsl.com 🌐 www.hooghlycsl.com

Shipyard: Nazirgunge Unit, Satyen Bose Road, P.O. Danesh SK Lane, P.S. Sanikrail, Howrah, West Bengal - 711109
☎ +91 (33)-2955 8283

CIN : U35900WB2017GOI223197, GSTIN : 19AAECH3640L1ZD



हुगली कोचीन शिपयार्ड लिमिटेड
(भारत सरकार का उद्यम)
HOOGHLY COCHIN SHIPYARD LIMITED
(A Govt. of India Enterprise)



व्युत्पन्न कुटुम्बकम्
ONE EARTH • ONE FAMILY • ONE FUTURE

Officer - in – Charge (tender)	Name: Vijay Singh Designation: Manager (SC&C) Email: vijay.singh@hooghlycsl.com Phone No: +91 8820480215
	Name: Siva Prasad SP Designation: Manager (Electrical) Email: sivaprasad.sp@hooghlycsl.com Phone No: +91 9487017033

Tender to be submitted by E-mail only. No hard copy quotation of the bid will be accepted.

Tender reference should be clearly indicated on the subject of the Mail.

Tenders should be submitted in two separate files as PART-I "TECHNO-COMMERCIAL" & PART-II "PRICE" (Password Protected) indicating the *tender number, due date of the tender and subject as in-line with the scope of supplies* in the Mail addressed to:

vijay.singh@hooghlycsl.com / sivaprasad.sp@hooghlycsl.com



For Hooghly Cochin Shipyard Limited

Signature and Seal of the Bidder(s)



Registered Office: Administrative Building, HCSL Premises, Satyen Bose Road,
P.O. Danesh Shaikh Lane, Nazirgunge, Howrah, West Bengal - 711 109.
☎ +91 (33)-2688 8282 ✉ contact@hooghlycsl.com 🌐 www.hooghlycsl.com

Shipyards: Nazirgunge Unit, Satyen Bose Road, P.O. Danesh SK Lane,
P.S. Sankrail, Howrah, West Bengal - 711109
☎ +91 (33)-2955 8283

CIN : U35900WB2017GOI223197, GSTIN : 19AAECH3640L1ZD

Minimum Qualification Criteria For Participating In The Tender Will Be As Follows

- 1.1. The Bidder shall be a single firm having experience in machinery erection, installation, and commissioning including propulsion system (Propeller Shaft sighting, alignment and installation), Rudder and Steering gear system onboard a ship in Shipyard / Marine application. Bidder shall be experienced in Pre-launch and Post launch machinery works.
- 1.2. Vendor should submit the details of work for preceding 03 years, FY (2021-22, 2022-23, 2023-24) of similar nature with 'at least one order of value 48 lacs or two orders of value 30 lacs each or 3 orders for 24 lacs each' in past 3 years. Similar nature means "the experience of successfully completed or under execution / progress similar works (as per clause 1.1 above). Experience within the past 3 years ending last day of month previous to one in which applications are only considered.
- 1.3. The Bidder should furnish the required work-specific information and satisfactory documentary evidence such as copy of work order / agreement and a certificate from the employer for satisfactory completion of work along with the GST Invoice or any other relevant document indicating completion of work shall be submitted to HCSL in support of its claim of experience.
- 1.4. The executed project shall comprise of complete work having comparable nature to that of machinery installation, shafting & commissioning. If the experience claimed by the bidder is of no relevance with respect to machinery installation, shafting & commissioning, then such experience will not be considered for pre-qualification. Decision taken by HCSL in this regard will be final.
- 1.5. Bidder shall not be under a declaration of ineligibility issued by Govt. of India/ State govt./ Public Sector Undertakings etc. The bidder shall not have been debarred / black listed by CSL/HCSL or by any of the Public Sector Undertaking or Government department etc.
- 1.6. Audited Balance sheets showing turnover, Profit & Loss account of the firm for the preceding 03 years, FY (2020-21, 2021-22, 2022-23) should be submitted along with the application for prequalification. **Net worth of the bidder must be positive as per the latest balance sheet. (MSE/NSIC may get exemptions as per prevailing Govt. norms).**
- 1.7. The average annual turnover of the bidder should be at least Rs. 45 lakhs during the last three preceding FY years (2020-21, 2021-22, 2022-23).
- 1.8. The Tenderer should enclose copy of statutory documents PAN, GST registration certificate, Income tax returns for last three FY (2020-21, 2021-22, 2022-23) or AY (2021-2022,2022-2023,2023-2024).

The tender documents can be downloaded from HCSL/ CSL website <http://hooghlycsl.com/www.cochinshipyard.com>. The tender documents are available on above mentioned link. All corrigenda, addenda, amendments and clarifications to this tender will be hosted in the website www.cochinshipyard.com or <http://www.eprocure.gov.in> and not in the newspaper. Bidders shall keep themselves updated with all such developments till the last date and time of submission of tender.

Tender administration: Tender procedure/administration/evaluation including correspondences and awarding of contract will be done by M/s. Hooghly Cochin Shipyard Limited, Howrah, West Bengal.

Officer - in - Charge for the above work:

Name: Arun M Y
Designation: Dy. Manager (Mechanical)
Email: arun.my@hooghlycsl.com
Phone No: +91 9486396216

Name: Vijay Singh
Designation: Manager (SC&C)
Email: vijay.singh@hooghlycsl.com
Phone No: +91 8820480215

Name: Siva Prasad SP
Designation: Manager (Electrical)
Email: sivaprasad.sp@hooghlycsl.com
Phone No: +91 9487017033

Signature and Seal of the Bidder(s)

TABLE OF CONTENTS

Sl. No.	DESCRIPTION	ANNEXURE
1	Technical Specification / Scope of Work	Annexure-1
2	Instruction to Bidders	Annexure-2
3	Terms & Conditions of Enquiry	Annexure-3
4	General Terms & Conditions	Annexure-4
5	Techno-Commercial Check List	Annexure-5
6	Price Bid Format	Annexure-6
7	Vendor Details	Annexure-7
8	NEFT Mandate Form	Annexure-8
9	List Of Deviation	Annexure-9
10	Form Of Bank Guarantee Towards EMD	Annexure-10
11	Format Of Bank Guarantee Towards SD	Annexure-11
12	Form Of Self Declaration	Annexure-12
13	Form Of Legal Cases	Annexure-13
14	Declaration- Border Sharing & Make in India	Annexure-14

Signature and Seal of the Bidder(s)

Technical Specification / Scope of Work:**Erection, Installation and Assistance for Commissioning of Equipment, Machineries, Steering Gear & Shafting for 50pax Hybrid Catamaran Vessels (06 Nos.) being Constructed at HCSL****1. DESCRIPTION OF WORK**

- 1.9. This tender enquiry pertains to the awarding of contract for Erection, Installation & Assistance for Commissioning for Equipment, machineries, steering gear and shafting including trials for **06 Nos. 50 Pax. Hybrid Electric Aluminium Ferries (Catamarans)**.
- 1.10. The work is to be carried out at **Hooghly Cochin Shipyard Ltd facility at Nazirgunge, Howrah.**
- 1.11. **Bidder are requested to obtain clarifications, if any, and carefully study the documents and the scope of work of Contractor and HCSL, before submitting your offer.**
- 1.12. The contractors are advised to familiarize themselves with the site conditions before quoting.

2. ABOUT THE VESSELS

Main Particulars of the Vessels

Length Overall (Hull)	:	24.8 m approx.
Breadth (mld.)	:	6.40 m approx.
Mean Draught (mld.)	:	0.9 m approx.
Propulsion	:	Conventional FPP with twin screw
Hull & main deck	:	Marine grade Aluminium
Super structure	:	FRP

The propulsion system shall be electric motors driven, supported by batteries, capable of being charged by electric supply from grid ashore. Diesel generators shall be provided on board for hybrid operation and diesel mode operation.

3. SCOPE OF WORK

- 3.1. The contractor shall carry out the installation of all the equipment & machineries as per the indicative list of machineries and equipment enclosed and as per the approved procedure for the project to the satisfaction of HCSL / Class / Owner's representative. The reference sample drawing is also enclosed with the tender document.
- 3.2. Propulsion and Steering gear systems includes shafts, stub-shafts, propellers and accessories, with coupling and propulsion motor, rudder, steering gear system (including piping) and accessories, etc.
- 3.3. The job includes collection of items/ equipment and related accessories from stores, transportation to the ship, machining of stern-tube and P-Bkt bosses, fitment & alignment onboard the ship and commissioning of systems/ equipment as per the drawings, key plan, schematic drawings and HCSL quality standards etc., and assistance for equipment commissioning / sea trial activities for builders and official trial. Completion of QC followed by CLASS/ OWNER surveyors is also under the scope of contract
- 3.4. After Keel sighting of respective Ship hull, shaft sighting can be done and measurement has to be transferred to required places, if required and is to be secured for future references

- 3.5. The entire propulsion and steering related welding will be done by the respective Hull contractor to the hull.
- 3.6. The bidder shall be in good coordination with the respective Hull sub-contractor during the entire process, as the welding will be done based on the concerned Machinery contractor input. The welding distortion has to be strictly monitored during the entire process. The alignment of Stern-tubes, P-Bkt bosses and Rudder trunks should be within the acceptable limit after welding of the same, same has to be ensured by the Machinery contractor.
- 3.7. The alignment survey has to be offered to HCSL QC followed by CLASS/ OWNER surveyors to their best satisfaction, before and after welding (of stern-tubes, P-Bkt bosses and Rudder trunks), after machining of the same and after installation of all the systems.
- 3.8. Machining of Stern-tubes and P-Bkt bosses have to be done as per standards, after the welding and same has to be offered to HCSL QC and to the complete satisfaction of CLASS/ OWNER surveyors. Line boring and face machining (if required as per site condition) of Stern-tubes and P-Bkt bosses have to be done after survey. Line boring and face machining (if required) will be under the scope of Machinery contractor.
 - a) Details of machining tools/ equipment have to be submitted along with previous experience in similar jobs.
 - b) The stern tube and P-Bkt boss material is aluminum, machining to be done as per the HCSL drawing and instruction. The hull structure is also aluminum.
 - c) The stern tube boss Aft & Fwd and P bracket boss to be machine in a single machine/shaft set up during night to avoid minimum deflection of hull due to temperature variation.
 - d) Final cut for machining to be done at night to avoid minimum deflection of hull due to temperature variation.
 - e) All accessories for facilitating the machining to be brought by the contractor.
 - f) The job includes machining, spot facing, drilling and tapping as mentioned in the attachment.
- 3.9. After machining of stern-tubes and P-Bkt bosses, fixing of Bearings along with housing has to be done on-site (drilling and tapping to be done as per the requirements). Shaft and propeller system has to be installed thereafter as per procedure and final fitment survey has to be offered to HCSL QC followed by CLASS/ OWNER surveyors to their best satisfaction.
- 3.10. Also, after rudder trunk final alignment survey, rudder trunk bearing to be installed (dry-ice fitment/ liquid nitrogen / shrink fitment method). Procurement of dry-ice / liquid nitrogen etc. will be under the scope of contractor. Fitment of Steering gear accessories like, rudder, hydraulic actuators, HPU (Hydraulic Powerpack Unit), Electrical panels, Valves, potentiometer (rudder angle indicator), limit switches, including necessary connections, ferrule connections, including piping etc. is under the scope of Machinery contractor.
- 3.11. All flexible and solid pipes shall be provided by HCSL, however necessary connectors, between solid and flexible pipes, solid and solid pipe, are to be procured by Machinery contractor, as per following details.
- 3.12. 15OD straight union of SS316L shall be supplied by the machinery contractor for steering gear system. The union supplied shall be complied with Class I piping system as per IRS Class. IRS certification shall be done by HCSL separately after the product supply (Note: if the item supplied is found as rejected, the machinery contractor shall take necessary action for immediate replacement without affecting the production schedule). Total requirement of connectors per vessel is 14 Nos and box clamps as required for steering gear

pipe support are also to be supplied by the contractor. Total requirement of box clamps per vessel is 15 Nos. **Sample to be submitted to HCSL for approval before delivering the entire lot at HCSL.**

Necessary drilling and tapping to be done at site as per the requirements. Final fitment survey has to be offered to HCSL QC followed by CLASS/ OWNER surveyors to their best satisfaction.

Rudder installation work includes establishing center line for rudder alignment works, erection of rudder trunk, rudder alignment, rudder fitment, actuator alignment, torque tightening and presenting survey.

- 3.13. The shaft and rudder should be locked prior to launching of the vessel and same has to be removed for final alignment of all the machineries and equipment.

Further, alignment of Tail shaft, stub-shaft with Coupling to Propulsion motor has to be done. Positioning of the equipment, alignment, marking of foundation bolts, removal of equipment for drilling the foundation, final fitment of equipment along with suitable sleeves/ gaskets, torque tightening of foundation bolts is under the scope of contractor. Same has to be offered to QC and subsequently to OWNER & CLASS surveyors to their best satisfaction during each stage of processes.

- 3.14. Final alignment of the shaft Line, the coupling of the various elements of shafting, final fixing of motor is carried out post launching of the vessel.

- 3.15. **Assistance for Commissioning** of the systems and offering the same to QC followed by CLASS/ OWNER surveyors is under the scope of Machinery contractor in the presence of concerned OEM.

- 3.16. All hot works like fitment of lifting lugs/ fabrication of special tools / cradle etc. if required for the erection of the foundation/machinery is under the scope of Machinery contractor. Temporary eye lug welding for rigging and shifting the equipment's to the position inside vessel for installation and removal of eye lugs after completion of machinery installation. Required welding machine's, lifting tools & tackles and rigging gears under contractor scope.

- 3.17. Removal and refit of machineries for realignment and commissioning and other works if required. The machineries to be positioned after the QA of equipment seats and drilling to be done on the foundation.

- 3.18. Removal and refit of pipes if required. Removal of sensitive parts prior to erection and refit of the same prior to commissioning.

- 3.19. The PI/II/STW/ Trials to be presented to the QC and subsequently to OWNER & CLASS surveyors after completing all related jobs including mopping the debris and dewatering if any.

- 3.20. Material movement & accounting of the items are in the work scope of contractor.

- 3.21. All tools, tackles and accessories required for the work are under the scope of the Machinery contractor and needs to comply with the safety rules and regulation of HCSL. Arranging required necessary jigs / fixtures, tools and tackles in order to execute the work like steel rules, punches, hammers, jacks, grinders, hydraulic jacks, chain block pulleys, drilling machine, bore cutters with suitable drill set and tap set etc., piano wire, torque wrench, cable strapping tool, production aids as per requirement. Calibration requirement if required for any tools and tackles shall be ensured by the contractor before commencement of the activity.

- 3.22. **All required installation hardware, foundation bolts & nuts (SS) of adequate Grade and strength, washer, nuts, copper shim for alignment and including rubber pad for vibration arrest materials shall be under contractor scope.**
- 3.23. Commissioning scope involves assistance for trials, testing and commissioning of all the equipment under the supervision of HCSL representative. OEM service engineer shall be provided wherever applicable.
- 3.24. DG trials includes commissioning of DGs including load test. Load tank will be provided by HCSL.
- 3.25. Filling of oil, levelling up, draining / refilling, installation of mountings, hoses, flexible fittings, end connections, bellows etc., as per the requirement at the site as necessary to undertaken by contractor under the scope.
- 3.26. Anchor, anchor drum winch & motor, anchor roller, chain stopper, Anchor rope winding on anchor drum, installation, alignment, commissioning and anchor trial including survey presenting as per QA under contractor scope,
- 3.27. Fireproof tarpaulin materials for covering up equipment's after installation is under contractor scope,
- 3.28. Survey presentation to Yard I&QC, Owners and Class authorities as per yard practices and standards.
- 3.29. Mobilization of entire labor / Workmanship (Skilled/Semiskilled/Unskilled) required for the turnkey work in accordance with the specification's drawings, schedule provided by HCSL. Qualified and experienced technicians to be engaged by the subcontractor.
- 3.30. Assisting yard engineers/service engineers for setting to work, commissioning and trials, including watch keeping during basin and sea trials. Assistance for the basic sea trials if to be conducted at HCSL unit at Nazirunge, Howrah.
- 3.31. Rectification of defects as per the comments from Yard I&QC, Owners & Class authorities.
- 3.32. Contractor shall maintain cleanliness and safety at site at all times including cleaning the oil spillage / water spillage / and other items associated with equipment installation and commissioning on daily basis.
- 3.33. Split air condition or equivalent of capacity 2T (Approx.) x 2 Nos in PORT and 2T (Approx.) x 2 Nos in STBD, including installation and commissioning including gas filling is under the scope of machinery contractor.

Note: All the welding works to the Hull structure will be done by the concerned Hull sub-contractor.

- 3.34. The contractor shall be responsible for any damage caused to the material supplied by HCSL. Compensation with penalty for damage or loss of the item will be recovered from the Contractor, in the event of loss or damage.

4. INSPECTION / TESTING/ QA AND QC

- 4.1. Work will be undertaken and inspected as per the quality standards provided by HCSL, and approved by CLASS and Owner of the vessels. The same may be seen prior bidding, if required.
- 4.2. Contractor to maintain the required dimensional accuracy and surface finish as per quality standards (to be provided by HCSL).
- 4.3. All works shall be as per strict compliance to weight control and approved HCSL drawings.
- 4.4. All correspondence with the Shipyard to be in English language. All documents and plans to be in English language and in metric units.

5. OTHER RESPONSIBILITIES OF THE OUTSOURCED FIRM FOR ALL CATEGORIES OF WORKS

- 5.1. The transportation, storage, preservation and protection of the materials etc., intended for installation on the ship, will be under the responsibility of the firm.
- 5.2. All works shall be carried out according to approved drawings issued by Yard and Yard standards provided.
- 5.3. Qualified Manpower, equipment, testing tools with valid certification, tools including winches for cabling through pipes etc. necessary for the work will be the responsibility of the firm, and should be carried out as per HCSL standards.
- 5.4. Yard has the right to change the schedules of the project to the interests of the company and the firm should be capable of adjusting the resources according to the instructions from the Yard contact person.
- 5.5. Detailed working schedule (Weekly/monthly) etc. to be prepared and submitted to yard personnel. However, a detailed overall schedule, in a reasonable manner should be submitted prior to commencement of work.
- 5.6. Localized lighting, DBs etc. for the smooth work to be arranged by the firm. Required lights/DBs etc. shall be arranged by Yard based on availability. However, providing portable extension boards are not under the scope of the yard.
- 5.7. Mobilizing own equipment, necessary working tools and tackles, safety and protective gear for their personnel inside the yard for carrying out the work as per Safety/Statutory rules/Yard rules of working people under the firm is the responsibility of the firm.
- 5.8. Firm shall be responsible for safety and welfare of all its employees employed for construction, and shall be responsible for payment of all salaries to their employees and other statutory dues and for all provisions of statutes governing them.
- 5.9. Once the item/material is issued to the contractor, proper accounting of the items consumed shall be maintained, till the delivery of vessel.
- 5.10. The contractor, on receipt of any material, is requested to immediately verify the quality and quantity of the material with respect to the requirement and inform the executing officer any shortage/discrepancy noted/anticipated well in advance so that HCSL can take corrective action in time.

6. Methodology of working

- 6.1. A detailed project report to be submitted prior to commencement of works.
- 6.2. The contractor must have a site-in charge / supervisor to execute work, with experience in Propeller shafting, rudder, steering gear and equipment's installation and commissioning. He shall keep close liaison with HCSL officers/supervisors concerned and ensure smooth and satisfactory progress of the work from time to time and shall be available for the entire duration of the project
- 6.3. Employees of the firm shall work under close coordination with yard personnel, structural contractors and Piping/Painting subcontractors with a conciliatory approach and team spirit to achieve the project completion in time.
- 6.4. The Contractor is expected to have full knowledge and understanding of the Labour rates, conditions, practices etc. prevalent in the Yard and premises. The contractor shall be entirely responsible for all matters related to manpower and labour engagement for the subject contract.

- 6.5. Issues related to availability and utilization of manpower shall be dealt by the Contractor. Availability of competent labour with requisite skills for the specified jobs shall be ensured by the contractor.
- 6.6. The complete work is to be carried out with the highest degree of workmanship under the inspection of HCSL, Classification society (when specifically indicated in the technical specifications), Ship owner, or any other agency nominated by Shipyard.
- 6.7. The contractor shall execute the work in every area under instruction/intimation to HCSL personnel at site. Clearance from HCSL in terms of permits/internal regulations etc. as applicable from time to time shall be obtained. The contractor shall obtain necessary hot work sanctions, permission to work in confined areas, safety clearance for scaffolding done by the contractor, electrical related provisions etc. as per HCSL safety rules.
- 6.8. The Contractor is to ensure proper cleanliness all around his work area while working on board ship. The contractor shall arrange to collect and clean up every day all the waste, scrap, debris etc. generated by his workmen while working on board the ship and other locations and deposit the same suitably at specified location at his cost to the complete satisfaction of Yard. In case of any failure on his part to comply with the requirement, Yard will arrange the required cleaning entirely at the contractor's cost.
- 6.9. The firm / contractor shall be responsible for any damage caused to the material supplied by HCSL. Compensation with penalty for damage or loss of the item will be recovered from the Contractor, in the event of loss or damage. The responsibility is limited only with respect to the damages caused due to any mistake or negligence of contractor.
- 6.10. Contractor / firm are required to work round the clock / Sundays/ holidays as per the requirement of concerned department in order to complete the work in time.
- 6.11. Any particulars/literature/information/certificates required by the Shipyard in connection with the work is to be forwarded free of cost.

7. Scope of Yard (HCSL)

- 7.1. Yard shall be providing design, drawings, manuals and equipment & machineries as listed for Machinery works for the mentioned scope of work.
- 7.2. Welding consumables (only Welding coil, if tig rod required the same shall be procured by the contractor only.)
- 7.3. Power supply & compressed air (at available pressure) at centralized points.
- 7.4. Services of HCSL cranes and forklifts will be provided, subject to availability.
- 7.5. Required space for fabrication & working inside the Yard (as on available area)
- 7.6. Staging / scaffolding.
- 7.7. Arranging HCSL QC/ Owner for inspection and survey
- 7.8. Required space for storage of materials inside the Yard. Space for positioning of contractor's office container if any.

8. Safety/Statutory Responsibility

- 8.1. The contractor shall be entirely responsible for the safety of all the personnel employed by him on the work. In this regard, he should adopt all the required safety measure and strictly comply with the safety regulations in force. A copy of HCSL's "Safety Rules for Contractors (Revised)" is available with Safety Department for reference.
- 8.2. The Contractor should arrange to suitably insure all his workmen/other personnel in this regard. HCSL will not be responsible for any injury or illness to the Contractor's workmen/other personnel during execution of the works due to whatsoever reasons.

- 8.3. In this regard, the Contractor will have to fully indemnify HCSL against any claims made by his workmen/other personnel.
- 8.4. The Contractor shall provide and maintain so as to be readily accessible during all working hours, a first aid box with prescribed contents at every place where he employs contract labour for executing the works.
- 8.5. Provision of required PPE and safety appliances to workmen to be provided by contractor.

9. Schedule Of Completion

- 9.1. Manpower mobilization within 5 days of issuance of Work Order or as per project schedule, within 5 days of intimation from HCSL.
- 9.2. Work of each vessel should be completed within 30 days from the date of commencement / 100% clearance from HCSL.
- 9.3. HCSL shall indicate the master construction schedule of completion of the work of vessel. The contractor in turn shall submit their detailed scheduled of completion of the work, in consultation with the officer In-charge. The progress of work shall be made in tandem with the progress of completion of the vessel allowing sufficient time for other interface activities/works.
- 9.4. Yard has the right to change the schedules of the project to the interests of the company and the firm should be capable of adjusting the resources according to the instructions from the Yard contact person.
- 9.5. Detailed working schedule (Weekly/monthly) etc to be prepared and submitted to yard personnel. However, a detailed overall schedule, in a reasonable manner should be submitted prior to commencement of work.

INDICATIVE LIST OF MACHINERIES

Sl. No.	Description	Location	Qty	Weight (Each) Approx. kg
1	Diesel Generators (70 KW)	Motor room	1	1400
2	Axial Fans	Battery Room	2	20
3	Axial Fans	Motor Room & Transformer Room	4	20
4	HPU - Steering Gear	Steering Gear Room	2	75
5	Steering Gear (Including Piping)	Steering Gear Room	2	100
6	Tiller	Steering Gear Room	2	10
7	Rudder	Steering Gear Room	2	50
8	Bilge Pump Submersible type	Steering Gear Room	2	4
9	Bilge Pump Submersible type	Motor Room	2	4
10	Bilge Pump Submersible type	Battery Room	2	4
11	Bilge Pump Submersible type	Fwd Void	2	4
12	Bilge Pump Submersible type	Fwd Void	2	4
13	Propulsion motor (50 KW)	Motor Room	2	250
14	Shore discharge pump	Motor Room	1	4
15	Fire Pump	Motor Room	2	95
16	Sea Water Cooling Pump	Motor Room	2	45
17	Fresh Water-Cooling Pump	Motor Room	2	45
18	Electrically Operated Winch (Port)	Main Deck - Fwd	2	65
19	Winch Roller 1	Main Deck - Fwd	2	30
20	Winch Roller 2	Main Deck - Fwd	2	30
21	Anchor, 61Kg-SHHP Type	Main Deck - Fwd	2	65
22	2way Damper	Motor Room	2	20
23	3Way Damper	Battery Room	2	25
24	Propeller + Shafting (Shaft length approx. 4.8mtr.)	Motor Room Outside	2	200
25	Air conditioning system for Battery room (Installation of Split AC 2 Ton or equivalent with gas filling)	Battery Room	4	40

REFERENCE DRAWINGS

1. General arrangement
2. Anchor & Winch arrangement
3. Propeller shafting arrangement details

Signature and Seal of the Bidder(s)

Instruction To Bidders

- A. Bidder shall not be under a declaration of ineligibility issued by Govt. of India / State govt./ Public Sector Undertakings etc.** The bidder shall not have been debarred / black listed by HCSL/CSL or by any of the Public Sector Undertaking or Government department etc.;
- B.** The bidder shall be deemed to have carefully examined the scope of work, technical specifications, general & special terms and conditions, and other necessities mentioned in the tender and have satisfied himself as to the nature and character of the works to be carried out, the site conditions and all relevant matters & details.
- C. All pages of offers including price bids, supporting documents etc. are to be signed by authorized signatory in each page and company seal should be affixed on each page.** In case of non-compliance, offer is liable for rejection.
- D.** Bidder should make sure that they comply with all the techno-commercial details in addition to adhere to all technical specifications during the whole process (i.e. Starting from bid submission to carry out scope of work as per work agreements and as applicable) and provide necessary MSE/NSIC Certificates to avail exemptions, if applicable.
- E. Un-priced bid to be submitted along with techno-commercial part (Part – I – Techno-commercial Bid) with details like percentage of taxes & duties applicable & details like “quoted/nil/included” to be mentioned for each line item as per Annexure-6.**
- F. Unprotected Price Bids/ Price Bids which are not password protected will be subject to rejection/disqualification of bid and HCSL as a whole reserves the right the cancel out such bids.**
- G. The bidders are advised to familiarize themselves with the site conditions before quoting.**
- H. Bidders are requested to obtain clarifications, if any, and carefully study documents of the tender, before bidding.**

Signature and Seal of the Bidder(s)

Terms & Conditions of Enquiry

Erection, Installation and Assistance for Commissioning of Equipment, Machineries, Steering Gear & Shafting for 50pax Hybrid Catamaran Vessels (06 Nos.) being constructed at Hooghly Cochin Shipyard Limited, Nazirgunge Unit, Howrah

2) Method of awarding contract

2.1 Contract will be concluded with Bidder qualifying technically (including eligibility criteria), agreeing to Commercial conditions and emerging as L1.

2.2. Work corresponding to the minimum Confirmed One (01 no.) + Two (02 nos.) options vessels will be placed as assured order for L1 bidder.

2.3. Work corresponding to minimum confirmed (01 no.) + One (01 no.) options vessels will be placed on the next inline bidder who matches the prices quoted by L1 bidder.

2.4. If none of the alternate bidders matches the L1 price, HCSL reserves the right to split the work / percentage of work to any number of bidders or to cancel the tender if required.

2.5 The 6th vessel is also kept as an option vessel and will be awarded, only after completion of 02 vessels successfully, to either of vendor (at L1 price) executing the contract, based on performance evaluation and schedule.

2.6. Only the minimum confirmed orders shall be placed on the bidders. The option vessels shall be confirmed by HCSL subject to decision of HCSL to go ahead with the subsequent vessel constructions and is subject to performance of the contractor on the first set of confirmed vessels awarded to the contractor. The performance shall be assessed by the Operations team based on the manpower mobilization / deployment, planned vs actual progress, quality of workmen etc.

2.7. Optional vessels shall be confirmed latest within 45 days from placement of work order on the contractor subject to completion of at least 1st vessel awarded to each contractor.

If any contractor, to whom the work is awarded, is not performing as per HCSL work plan, HCSL officer in charge has the right to modify / cancel the scope of work or volume of work in WO and allocate to another contractor as required.

HCSL reserves the right to cancel the tender if required.

3) Work progress and schedule of completion

3.1 HCSL shall indicate the master construction schedule of completion of the work of vessel after awarding the contract. The contractor in turn shall submit their detailed scheduled of completion of the work, in consultation with the officer in-charge. The progress of work shall be made in tandem with the progress of completion of the vessel allowing sufficient time for other interface activities / works.

3.2 Yard has the right to change the schedules of the project in the interests of the company and the firm should be capable of adjusting the resources according to the instructions from the yard contact person.

3.3 Detailed working schedule (weekly/monthly) etc to be prepared and submitted to yard personnel in the request format (MS Project /MS Excel/ MS Word). However, a detailed overall schedule, in a reasonable manner should be submitted prior to commencement of work.

3.4 Progress of work to be updated to officer in charge in requested format (MS Project /MS Excel/ MS Word) twice in a month/ as and when a review meeting is called for.

4) Inspection

4.1) The complete work has to be carried out under the survey of ship classification society / owner / HCSL.

5) Validity

5.1) The offer shall be valid for acceptance for a period of 90 days from the date of opening of the Part-I Techno-Commercial Bid.

6) Validity of contract

6.1 Once the contract is awarded, the price offered and mutually agreed shall remain firm till completion of work and no escalation in labour, transportation cost etc. shall be allowed by HCSL on whatsoever reason thereafter.

7) Payment terms

Payment will be made for each vessel separately.

7.1. Payment will be made in 3 stages: (Below percentage is of total contracted value of vessel)

- i) First 40% payment will be made after launching of the vessel.
- ii) Next 40% payment will be made after successful completion of Basin Trials.
- iii) Next 20% payment will be made after successful completion of Sea Trials and closing of all class and owner's comments.

7.1.1 Payment shall be made on the basis of certification by HCSL officer in-charge. Contractor shall submit work completion certificate issued by HCSL authority.

7.1.2. The payment shall be made within 30 days from submission of invoice along with the work completion certificate.

7.1.3. All claims for payment for the work/ additional work (if any as per special instruction from OIC) shall be submitted by the contractor within one month of completion of work.

7.1.4. Payment will be made by RTGS/NEFT to the account of agency. The name of the bank, branch, A/C No., IFSC code & other particulars shall be furnished by the agency in the proforma of HCSL (Annexure-8).

7.1.5 Above% payment of order value with applicable taxes will be released against original invoice subject to the full satisfaction and acceptance of work / items by Officer -In-Charge. Original tax invoice should contain GST number of both parties and submit in triplicate.

7.1.6 Statutory levies such as I.T, Contribution towards PF, ESI etc., shall be paid by contractor and documents as a proof to be submitted along with invoice.

7.1.7 Contractor shall indicate details such as PAN, GST. required for processing payment. Payments will be made through NEFT/RTGS/Cheque mode and necessary details shall be

furnished by the contractor. HCSL reserves the right for the deduction of taxes and duties as applicable from the bill or invoice.

7.2. Quantum of work indicated at Annexure-1 is final however additional works as per clause 8 of Annexure-3, also to be considered while quoting, actual quantum of work executed at site shall be considered for the payment purpose.

8). Additional works:

Additional works up to 5% growth of work on the machinery items in terms to be envisaged and is to be undertaken without any additional price impact.

a) Any minor modifications, resulting from the change in statutory regulations prevailing at the time of final inspection of work by classification society, to be carried out by the contractor free of cost. In case of rework/modification /additional work, the same is to be discussed and clearance to be obtained from the Officer-In-Charge before commencement of the work.

b) Contractor shall carry out the complete work in accordance with shipyard's approved drawings. Any minor modifications from drawing or any other work or supply of material, which is not specified hereunder, but is considered incidental and essential for the successful completion of the job shall be carried out by the contractor without any additional charge.

c) Contractor shall execute, during or after completion of the work, any minor job connected with the work, that is considered necessary by shipyard and/or classification society.

9). MSE/ NSIC benefits: (If and only if the certificate issued is in the relevant field)

A. The following benefits are extended for all the firms who are registered with district industries center and come under the category of **Micro and Small Enterprises** holding a valid Entrepreneurs Memorandum (EM) part ii certificate or Udyog Aadhaar Certificate. However, in order to avail the benefits as per public procurement policy for MSE's orders, 2012, all MSE bidders are required to declare their Udyog Aadhaar Memorandum (UAM) number in Central Public Procurement Portal (CPPP) compulsorily.

- Tender Forms Shall Be Issued Free of Cost.
- Payment of earnest money deposit (EMD) is exempted.

B. For all firms who are registered with National Small Industries Corporation (NSIC) and come under Micro and Small Enterprises holding a valid NSIC certificate, the below benefit also extended in addition to above.

Waiver of security deposit (SD) for the performance of the contract (5% of the order value by the way of bank guarantee till the supplies are completed), up to financial limit as mentioned in NSIC certificate.

C. This tender shall be based on MSE order dated 23rd march 2012, pertaining to public procurement policy.

D. MSE's quoting price band L1 + 15% (in the ascending order) may be awarded complete work, considering spirit of policy for enhancing the government procurement from MSE's.

E. Traders are exempted from the benefits from Public Procurement Policy, for MSEs Order, 2012. As mentioned in O.M. No. 5/2(2)/2021-E/P & G/Policy dated 02.07.2021, Retail and

Wholesale traders can register on Udyam Registration Portal for the purpose of Priority Sector Lending (PSL) only.

10) Security deposit:

The successful tenderer shall remit 5% of the value of the contract as security deposit within 07 days of receipt of the work order. This amount after adjusting the EMD may be remitted by way of demand draft or bank guarantee (in approved proforma of HCSL) from any of the scheduled banks, valid till the satisfactory completion of the entire work i.e. completion of sea trials. The Security Deposit will be released after satisfactory completion of the contract i.e. completion of sea trials and on certification of nil liability to HCSL by Officer-in charge.

11) Liquidated Damages:

11.1 The progress of work will be monitored against the mutually agreed detailed schedule. Liquidated damages for delays in execution of the work envisaged as per this order, for any reason other than force majeure conditions, will be recovered at the rate of half percent of the value of the contract per week or part thereof, subject to a maximum of ten (10) percent of the value of the contract.

12) Place of Work:

Hooghly Cochin Shipyard Limited

131/1, Satyen Bose Rd, Nazirganj,

Guabaria, Mourigram, Howrah- 711109, India.

13) Risk Purchase:

If the contractor fails to commence the work in time, as per the terms in work order or violate any other terms & conditions of work order, HCSL shall have the following rights.

- a) To terminate the contract within 7 days of notice forfeiting the Security deposit
- b) To initiate alternative arrangements at the risk and cost of the contractor.

If the firm's performance is found not satisfactory with regard to the progress of work, quality, and time factor, labour dispute with their workers, poor safety record, contract shall be terminated with 7 day notice and no claim whatsoever will be entertained in this regard from the firm.

14) Force Majeure

14.1 Should failure in performance of the contract or part thereof arise from war insurrection, restraint imposed by government, act of legislature or other statutory authority or illegal strike, riot, legal lock-out, flood, fire, explosion, act of God or any inevitable or unforeseen event beyond human control which may be construed as reasonable ground for an extension of time, HCSL may allow such additional time as is mutually agreed to be justified by the circumstances of the case. The

occurrence/cessation of force majeure situation is to be informed with documentary evidence within 15 days from the date of occurrence/cessation.

15) Arbitrations

15.1 Any disputes arising during the execution of the contract shall, in the first instance be settled by mutual discussions and negotiations. The results of such resolution of dispute shall be incorporated as an amendment to the contract, failing which the parties can resort to arbitration.

15.2 If any dispute, disagreement or question arising out of or relating to or in consequence of the contract, or to its fulfillment, or the validity of enforcement thereof, cannot be settled mutually or the settlement of which is not herein specifically provided for, then the dispute shall within thirty days from the date either party informs the other in writing that such disputes, disagreement exists, be referred to arbitration. The arbitrators shall be appointed and the arbitration proceedings shall be conducted in accordance with and subject to the Arbitration and Conciliation Act, 1996 (No. 26 of 1996) as amended from time to time and the decision of the Arbitrators shall be final and binding on the parties here to. The arbitration will be done by a Board comprising one officer nominated by each party, and a mutually agreed Umpire. Each party shall bear its own cost of preparing and presenting its case. The cost of arbitration shall be shared equally by the parties unless the award provides otherwise. The enforcement of the award shall be governed by the rules and procedures in force in the State in which it is to be executed. Performance under this Contract shall however, continue during arbitration proceedings and no payment due or payable by the parties hereto shall be withheld unless any such payment is or forms a part of the subject matter of arbitration proceedings.

15.3 In case of disputes, the same will be subjected to the jurisdiction of courts at Kolkata, West Bengal, India only. Governing law should be Indian law and place and seat of arbitration is at Kolkata, West Bengal. Language of arbitration should be English.

16 Labour Law & Regulations (Time to time amendments by Govt. to be strictly followed)

16.1 The contractor shall undertake and execute the work with contract labour only after taking license from the appropriate authority under the contract labour (regulation & abolition) act 1970.

16.2 The contractor shall observe and comply with the provisions of all labour and industrial laws and enactments and shall comply with and implement the provisions of the factories act , 1948, employees provident funds at miscellaneous provisions act, 1952, employees state insurance act, payment of gratuity act, minimum wages act, payment of bonus act, contract labour (regulation and abolition) act and all other enactments as are applicable to his and his workmen employed by him. The contractor shall inform HCSL his license number prim the Central Labour Commissioner.

16.3 All contract workmen, except those exempted under the respective acts, shall necessarily be insured under the ESI scheme and be made members of the EPF scheme from the day of their engagement as contract workmen in the company. All such insured contract workmen should carry with them their ESI identity card for verification by the authorities. No contract workmen without a valid ESI identity card for verification by the authorities will be permitted to work in the company.

16.4 The Contractor shall submit the labour reports/ returns as required by the company from time to time in respect of their workmen in standard format to the concerned contracting officer so as to

enable the same to reach personnel department by the 5th of every month. Delayed submission of the same shall attract penal interest /damages at the rate as levied by the respective authorities under the relevant Acts.

16.5 The Contractor shall maintain the records viz. muster roll, acquittance roll with full details, account books etc., in original. These are required for inspection by the concerned authorities under each scheme.

16.6 If the Contractor fails to pay any contributions, charges or other amounts payable under any of the aforementioned provisions of law, HCSL shall deduct or adjust amounts equivalent to such contribution, charges or amounts from amount payable to him by HCSL, including any deposit or amounts payable against bills and make payments on his account to the appropriate authority. He shall not be entitled to question or challenge such deductions, adjustments or payment made by HCSL.

16.7 Any other amount payable under any law or in respect of any person employed by the Contractor, if not paid by him, shall be deducted or adjusted by HCSL out of any amount payable to the Contractor including any Security Receipt and paid ever or withheld for payment by HCSL.

16.8 The Contractor shall be fully responsible for the conduct and discipline of the workmen employed by him in the Company premises. If such workmen commit any misconduct or criminal act inside the Company, the Contractor shall take appropriate action against such workmen. The contractor shall abide by the instructions/ guidelines issued by the Company for maintenance of discipline and good conduct among the workmen employed by him.

16.9 All person who are engaged for various works in HCSL either directly or through contractors, should produce the following documents prior to issuing their entry passes:

16.9.1 Aadhar/attested copy of Aadhar with photo and address particulars. **OR**

16.9.2 Police clearance certificate with photo and address particulars. (Police clearance certificate to the effect that the concerned person is staying in the area of jurisdiction of the certificate issuing police station and that the person is not involved in any criminal offences as per the records available therein.)

16.10 Application and declaration for enrolling under employees provident fund and ESI Scheme.

16.11 Contractors are requested to familiarize themselves with the labour rules & regulations prevailing in HCSL including the labour wage pattern of contract labours.

17) Safety of personnel and first aid

17.1 The contractor shall be entirely responsible for the safety of all the personnel employed by him on the work. In this regard, he may adopt all the required safety measures and strictly comply with the safety regulations in force. Detailed information and references available with HSE department of HCSL.

17.2 The Contractor may arrange to suitably insure all his workmen/ other personnel in this regard. HCSL will not be responsible for any injury or illness to the Contractor's workmen/other personnel during execution of the works due to whatsoever reasons.

17.3 In this regard, the Contractor will have to fully indemnify HCSL against any claims made by his workmen/other personnel.

17.4 The Contractor shall provide and maintain so as to be readily accessible during all working hours, a first aid box with prescribed contents at every place where he employs contract labour for executing the works.

18) IMS Guidelines

18.1 HCSL implemented an Integrated Management System (IMS) consisting of Environmental Management system (EMS), Occupational Health and Safety Management System (OHSMS) and the Quality Management System (QMS) within the yard. As part of IMS, subcontractors shall comply with the following measures related to the Quality, Health, and Safety & Environment (QHSE) policy of HCSL.

18.1.1 Meeting or exceeding customer requirements.

18.1.2 Assuring quality of the products and service.

18.1.3. Preventing occupational ill health and injuries.

18.1.4 Ensuring safe work sites.

18.1.5 Conserving natural resources.

18.1.6 Preventing / minimizing air, water & land pollution.

18.1.7 Handling and disposal of Hazardous wastes safely.

18.1.8 Complying with statutory & regulatory and other requirements.

18.1.9 Developing skills and motivating employees.

18.2 Occupational Health, safety & Environmental requirements of HCSL shall also include the following.

18.2.1 The contractor (or a sub-contractor performing work on behalf of the contractor) is deemed to comply with the Occupational health, safety and environmental policy of the company and also to all operational controls/standard operating procedures and shall undertake the work in total compliance with the requirements of the established Integrated Management System (IMS) of the company.

18.2.2 The Contractor shall undertake the work in total compliance with all applicable legal/statutory requirements related to occupational health, safety and environment effective in the state of West Bengal.

18.2.3 It is the sole responsibility of the contractor to assure that any sub-contractor/s who shall perform works in company lands/facilities/worksites on behalf of the contractor, is also following all requirements related to the Integrated Management System of the company and the health/safety/environmental rules effective in the state.

18.2.4 The contractor shall provide/ implement and operate/ practice all occupational health, Safety and environmental management measures/facilities, for their period of contract, in their activities/at their work sites, which shall be required according to the IMS of the company that required by the health/safety/environmental rules established and effective in the state, at their own cost.

18.2.5 If any contractor failed to comply with or violated any clauses/requirements of occupational health, safety and environmental rules effective in the state, in their activities or at work sites and

the same shall be exposed to the government or any competent authorities upon inspections, the contractor shall be solely responsible for all liabilities caused by his/her action and shall be responsible for paying the penalty and taking stipulated corrective actions insisted by the authorities within the specified time, at their own cost. Any liability to the company in this regard needs to be compensated by the contractor.

18.2.6 Upon completion of the work, contractor shall clear the area and shall not leave any Occupational health/safety/environmental liabilities to the company, from their activities at the worksites.

18.2.7 Any clarification related to IMS requirements of the yard, may be obtained by the contractor from the Officer in charge of QC or the authorized representative of the contract, prior to the commencement of work.

19) Electricity Rules & Regulation

19.1 The contractor shall adhere to the various rules in respect of electrical installation as per the Indian Electricity Rules and Regulations and Electrical Inspectorate Standards in order to make sure that men and materials are safe from hazards.

20) Secrecy clause

20.1 The CONTRACTOR shall be responsible to ensure that all persons employed by them in the execution of any work in connection with this contract are aware of the provisions of the official secrets act 1923 and to comply with the same. The CONTRACTOR shall also ensure secrecy of design, construction, equipment and completion of the vessel. Any information provided to you under this contract is to be treated as strictly confidential and is not to be disclosed to any person or persons not concerned therewith

20.2 All documents under this Contract transferred between the parties shall be treated as UNCLASSIFIED unless explicitly marked.

20.3 The CONTRACTOR shall ensure that their organization, suppliers/ installation agency/test and trials teams etc shall not communicate for use in advertising, publicity, sales release or in any other medium, system details, photographs and reproduction of equipment and their fitment on board Navy/coast guard/private owner vessels without written approval from the competent authority of HCSL.

21) Statutory Conditions and Labor Laws

- a. The firm must comply with statutory requirements, like ESI/EPF etc., and other labor laws/regulations in force and as amended from time to time.
- b. Under no circumstances HCSL will be responsible for any statutory compliance related to Labor, Central/State Government if any.
- c. The contractor shall provide the minimum wage rate of the Central Government & submit the bank statement of wage payment along with the bill.**

22) Indemnity Clause

The firm shall indemnify HCSL and keep harmless against any or all claims, liabilities, damages, losses, costs, charges, expenses, proceedings and actions of any nature whatsoever made or instituted against HCSL directly or indirectly by reason of:

- a. Any wrongful, incorrect, dishonest, criminal, fraudulent or negligent work, misfeasance, disregard of duties by personnel of the firm; and/or
- b. Any theft, robbery, fraud or wrongful act or omission by personnel of the firm.

Signature and Seal of the Bidder(s)

General Terms & Conditions

- 1) The contractor must have a dedicated site-in charge/ supervisor to execute work, with a minimum experience of 3 yrs. in similar works.
- 2) The Contractor shall have to engage men on round the clock basis and also on Sundays and holidays, if required. Work has to be completed to the satisfaction of Hooghly Cochin Shipyard Engineers deputed for the job. The job should be completed at the time specified by the supervising Engineer for each stage of work.
- 3) The upper age limit of all workers and supervisors employed by the contractor / firm and those contractors who do or supervise the job themselves shall be as per the prevailing rules of HCSL.
- 4) The work will be undertaken by only qualified welders of the contractor. Towards this, HCSL will provide the WPS and PQR. Welders will have to be qualified by Class by HCSL. The subcontractor must pay for the welder qualification, testing and certification charges to HCSL on actuals. The contractor must retain the qualified welders till the completion of the project.
- 5) Work will be undertaken and inspected as per the quality standards provided by HCSL, and approved by CLASS and Owner of the vessels.
- 6) Area and steel skids will be provided by HCSL, leveling of the skid will be undertaken by contractor to the satisfaction of HCSL QC. Required production aids shall be arranged by Contractors.
- 7) The contractor shall arrange to collect and clean up every day all waste, scraps, debris, etc. generated by the work men while working onboard the vessel and other locations and dispose the same suitably at his cost to the full satisfaction of HCSL. In case any failure on his part to comply with this requirement, HCSL will arrange the required cleaning entirely at the contractor's cost.
- 8) Assistant General Manager (P&P) or his authorized representative will be the Officer-in-charge of this Contract.
- 9) Material supplied by HCSL may not be in the required size and shape. These may be cut and prepared after proper nesting by the Contractor. Special care to be taken to reduce wastages. Shortage of any material (supplied by HCSL) arising out of excess wastages due to improper planning shall have to be made up by Contractor free of cost.
- 10) The contractor shall be responsible for any damage caused to the material supplied by HCSL. Compensation with penalty for damage or loss of the item will be recovered from the Contractor, in the event of loss or damage.

11) Any particulars/literature/information/certificates required by the Shipyard in connection with the work is to be forwarded free of cost.

12) All correspondence with the Shipyard to be in English language. All documents and plans to be in English language and in metric units.

13) Providing all personnel protective items like safety helmets, gloves, welding shields, goggles, leg guards, safety belts, boiler suit, safety shoes, safety belt etc. to their employees.

Signature and Seal of the Bidder(s)

Techno-commercial check list				
S#.	DESCRIPTION	COMPLIANCE		REMARKS
		YES	NO	
1.	Submission of Tender in Two Bid			
2.	Service duration Confirmation to yards timelines. The work shall be completed as per the instructions from Officer-In-charge of the work as per schedule.			
3.	EMD submitted with the Bid.			
4.	Validity of offer – 90 days			
5.	Payment Terms			
6.	ITR, Balance Sheets, Profit & loss statement for FY 2020-21, 2021-22 & 2022-23 submitted with the Bid.			
7.	The Prices offered should be fixed and firm till the completion of delivery, in case the work order is placed with you.			
8.	Unpriced bid attached, as per format with taxes & duties as applicable			
9.	Clearly Understood the work scope & related supply of items			
10.	Have you considered Taxes, duties, levies, packing & forwarding etc., if any, in the offer?			
11.	Compliance with Pre-qualification criterion			
12.	L.D. payable as per relevant clause in the tender document.			
13.	Disputes in connection with contract subject to jurisdiction of courts at Kolkata India			
14.	Termination of contract/Risk purchase as per relevant clause in the general terms of enquiry.			
15.	Compliance with Pre-qualification criteria.			
16.	Confirm all other terms and conditions of enquiry are acceptable.			
17.	MSE/NSIC, in similar field of service ,if yes document required along with technical bid.			
18.	PAN, GST certificate submitted with the Bid			
19.	ESIC/EPF Registration Cert. (As applicable)			
20.	Contractor should have annual turnover at least Rs. 20 lakhs in each financial year during the last three preceding years, if yes supporting document to be submitted along with technical bid.			
21.	You have read & understood all the Terms & Conditions of the tender			

Annexure -6

PRICE BID

Erection, Installation and Assistance for Commissioning of Equipment, Machineries, Steering Gear & Shafting for 50pax Hybrid Catamaran Vessel		FOR ONE VESSEL					
Sl. No.	Description	Location	Quantity / Vessel (A)	Weight (Each) Approx. kg	Unit rate (without GST) (B)	Total (without GST) (C=A X B)	GST%
1	Diesel Generators (70 KW)	Motor room	1	1400			
2	Axial Fans	Battery Room	2	20			
3	Axial Fans	Motor Room & Transformer Room	4	20			
4	HPU - Steering Gear	Steering Gear Room	2	75			
5	Steering Gear (including Piping)	Steering Gear Room	2	100			
6	Tiller	Steering Gear Room	2	10			
7	Rudder	Steering Gear Room	2	50			
8	Bilge Pump Submersible type	Steering Gear Room	2	4			
9	Bilge Pump Submersible type	Motor Room	2	4			
10	Bilge Pump Submersible type	Battery Room	2	4			
11	Bilge Pump Submersible type	Fwd Void	2	4			
12	Bilge Pump Submersible type	Fwd Void	2	4			
13	Propulsion motor	Motor Room	2	250			

14	Shore discharge pump	Motor Room	1	4				
15	Fire Pump	Motor Room	2	95				
16	Sea Water Cooling Pump	Motor Room	2	45				
17	Fresh Water-Cooling Pump	Motor Room	2	45				
18	Electrically Operated Winch (Port)	Main Deck - Fwd	2	65				
19	Winch Roller 1	Main Deck - Fwd	2	30				
20	Winch Roller 2	Main Deck - Fwd	2	30				
21	Anchor, 61Kg-SHHP Type	Main Deck - Fwd	2	65				
22	2way Damper	Motor Room	2	20				
23	3Way Damper	Battery Room	2	25				
24	Propeller + Shafting (Shaft length approx. 4.8mtr.)	Motor Room Outside	2	200				
25	Air conditioning system for Battery room (Installation of Split AC 2 Ton with gas filling)	Battery Room	4	40				
			Total Cost for One Vessel					
			GST (%)					
			Total Cost for One Vessel with GST					
			Gr. Total For 06 Vessels with GST					

Note:

1. The quoted price will be valid for a period of 3 (three) months.
2. Quoting for all serials is mandatory. Partially quoting for few serials shall result in rejection of the bid.
3. L1 Bidder will be decided without considering Taxes.
4. Rate agreed upon as per quotation shall remain firm and fixed till conclusion of contract.
5. Bidders shall quote total amount in figures and in words. Corrections and additions if any must be attested / duly signed by the bidder. In the case of error in multiplication / addition in amount calculated, unit rate quoted will be considered as correct and the amount will be calculated accordingly. Conditional rebates & discounts, incomplete/ambiguous offers are likely to be rejected.
6. Bidder has to submit the price bid as mentioned in the format only, otherwise bid will be rejected
7. Un-priced bid to be submitted along with techno-commercial part (**Part – I – Techno-commercial Bid**) with details like “**quoted/nil/included**” to be mentioned for each line item

Grand Total Amount (in Words) Rupees

*Any modifications or alterations or additional notes added to the above format will straight away leads to rejection of the offer

Signature of authorized personnel:

Name of firm or authorized signatory:

Designation:

Address:

Contact No:

Vendor details (to be submitted along with TECHNICAL BID)

1	Name of Bidder/Firm	
2	Registered office Address of Company/firm in Kolkata/Howrah: Local office address at Kolkata/Howrah (if held):	
3	Telephone No./Fax No./Mobile No	
4	E-mail address:	
5	Names of the contact person & Designation: (of person in connection with this tender) :	1) 2) 3)
6	Type of Entity-Pro praetorship/Partnership firm/company/NSIC/MSE Category etc. (Please attach registration certificate of Firm/Partnership agreement/proprietorship documents)	
7	Cost of Tender Details (DD No. Name of Bank)	
8	EMD Details (DD No. Name of Bank)	
9	PAN Card Number (Self-attested copy of PAN card has to be Submitted)	
	GST Registration No. (Self-attested copy has to be Submitted)	
10	Whether the agency has been blacklisted/de barred or given tender holiday or contract terminated before expiry of the contract period by any govt. autonomous bodies/organizations where bidder has provided services earlier due to deficiencies in service or misconduct etc.	Yes/No (Please tick as applicable) If yes, please furnish details on a separate sheet

Certified that the above information is true to the best of our belief and information.

Place:

Date:

Signature of Supplier/Authorized signature of firm/agency:

Name of Supplier or authorized signatory of firm/agency:

Designation:

NEFT mandate form

(ON THE LETTER HEAD OF THE BIDDER)

Electronic Payment Mandate Form

(Mandate for receiving payments through RTGS/NEFT Hooghly Cochin Shipyard Ltd)

- 1) Vendor Name
- 2) Vendor Address with Phone No
- 3) Vendor Code
- 4) Permanent Account No. (PAN)
- 5) Particulars of Bank Account
 - a. Name of the Bank
 - b. Name of the Branch
 - c. Branch Code
 - d. NEFT Code of the Bank
 - e. City Name
 - f. Branch Location
 - g. Branch Telephone No.
 - h. Bank IFSC Code
 - i. 9-Digit MICR Code

(Where MICR is starting with "0". Please take the correct code from your bank for proper identification of city, bank, branch)

 - i. Type of the Account (S.B Current or Cash Credit) with code (010/011/013)
 - j. Account Number (as appearing on the cheque book)

- 6 Email Address of Vendor
- 7 Date of Effect of RTGS/NEFT in your Bank

We hereby declare that the particulars given above are correct and complete. If the transaction is delayed or lost because of incomplete or incorrect information, we would not hold the company responsible.

(.....)
Signature of Employee

Bank Certificate

We certify that _____ has an Account
No. _____ with us and we confirm that the details given above are correct as per our records.

Date:

Place: (.....)
Authorized official of Bank

Note: Please enclose a cancelled un-signed cheque leaf to enable us to verify the details mentioned above.

Compliance statement- List of Deviations	PAGE 1 OF 1
-------------------------------------------------	--------------------

Tender Name: Erection, Installation and Assistance for Commissioning of Equipment, Machineries, Steering Gear & Shafting for 50pax Hybrid Catamaran Vessels (06 Nos.) being constructed at Hooghly Cochin Shipyard Limited, Nazirgunge Unit, Howrah.

TENDER NO:

DATE:

We hereby confirm and truly declare that our Offer / Bid No.datedis in full compliance with the documents issued against the Tender No. -----dated -----, except for the deviations listed below:

LIST OF DEVIATIONS (HCSL reserves the right to reject offers with deviations)

Sl. No.	Description / Tender Reference	Reasons for Deviation

Name of tenderer:

Date:

Name & Designation

Seal & Signature

(Company Seal)

Form of bank Guarantee towards EMD

(On stamp paper of value Rs. 200/-)

This deed of GURANTEE made on day ofTwo thousand Eighteen between HCSL on the one part and (Name and address of the bank) of the other part is as follows: -

In consideration of the HCSL having allowed M/s..... (Hereinafter referred to as ‘the Supplier’) to submit Tender No..... to them without Earnest Money according to the conditions of such Tender Notification.

We..... (here enter the name of ‘the Bank’) a Company incorporated under theAct and having its registered office at(hereinafter referred to as ‘the bank’) undertake to pay to HCSL on demand at Kolkata the sum of money payable as Earnest Money in respect of the Tender No.....made by the Supplier, in case the Supplier withdraws the tender before the date of firmness stipulated or when the tender is accepted by or on behalf of the HCSL the Supplier makes default in furnishing the Security Deposit or in entering into an agreement as required by the HCSL or otherwise commits any breach of the terms and conditions of the tender.

We,Bank Guarantee to pay the amount due and payable under this guarantee without any demur merely on demand from the HCSL. Any such demand made on the Bank shall be conclusive as regards the amount due and payable by the Bank under this guarantee. The liability of the surety shall be restricted to Rs(Rs..... only)

This guarantee shall not be avoided, released or affected by any variation in the terms of the tender, acceptance or the contract between the Contractor and the HCSL or any neglect indulgence or forbearance by the HCSL.

This guarantee shall remain in full force and effect during the period that would be taken for the finalization of the tender and till the HCSL certifies that the terms and conditions of the said tender have been fully and properly carried out by the Supplier and accordingly discharges this guarantee or for Six Months from the date of issue of this guarantee whichever is earlier. A notice of the claim under this guarantee may be served on the Bank within Six Months after the said period in which case the same

shall be enforceable against the Bank notwithstanding the fact that the same is enforced after the expiry of the said period.

The decision of the CEO, HCSL as to whether the occasion or the ground has arisen for the demand of the surety form Bank shall be final. The HCSL shall be at liberty to act as though the Bank were the principal debtor.

We, the said Bank lastly undertake not to revoke this guarantee during its currency except with the previous consent of the HCSL in writing and agree that any change in the constitution of the said contractor or the said Bank shall not discharge our liability hereunder.

In witness whereof we have hereunto set our hand and seal this. day
.....of.....Two thousand
and

Place:

Date:

**Bank guarantee in lieu of security deposit/
Warranty guarantee**

To
HOOGHLY COCHIN SHIPYARD LTD
(Govt. of India Enterprise)
Satyen Bose Road,
Danesh SK Lane (PO),
Nazirgunge, Howrah,
West Bengal - 711109.

WHEREAS(Name & Address of Supplier) (hereinafter called "**the Supplier**") has undertaken, in pursuance of Contract.....No.....Dated:.....to execute(Name of Contract and brief description of works) (hereinafter called "**the Contract**").

AND WHEREAS it has been stipulated by **HOOGHLY COCHIN SHIPYARD LTD** (The Buyer – hereinafter called "**HCSL**") in the said contract that the Supplier shall furnish **HCSL** with a Bank Guarantee for the sum specified therein as security for compliance with the Supplier’s obligations in accordance with the Contract.

AND WHEREAS we have agreed to give the Supplier such a Bank Guarantee.

NOWHEREFORE we.....(Name of the Bank) having its Head Office at.....(Address of Head Office) and acting through its branch office at.....(Address of the executing branch)(hereinafter called "the Bank") hereby affirm that we are the Guarantor and responsible to **HCSL**, on behalf of the Supplier upto a total of.....(amount of Guarantee) in words).

We, the bank, hereby irrevocably undertake to pay you any amount not exceeding in total the Guarantee Amount upon receipt by us of your demand in writing accompanied by the following documents:

1. Your signed statement certifying that the Supplier is in breach of his obligation(s) under the Contract and the respect in which the Supplier is in breach.
2. Your signed statement certifying that the Supplier has been given a prior written notice by email from you to make good the aforesaid breach and that the Supplier still failed to fulfill the Contract within 30 days of such notice. A copy of such notice given by email to the Supplier shall be attached to the demand for payment.

Any demand for payment should contain your authorized signatures which must be authorized by your bankers or by a notary public.

We, the Bank, further agree that no change or addition to or other modification of the terms of the Contract or of the Works to be performed there under or of any of the Contract documents which may be made between **HCSL** and the Supplier shall in any way release us from any liability under this guarantee, and we hereby waive notice of any such change, addition or modification. We, the Bank,

further agree that any change in the constitution of the said contractor or the said bank shall not discharge our liability hereunder.

Notwithstanding anything contained herein:

1. Our liability under this Bank Guarantee shall not exceed(only).
2. This Bank Guarantee shall be valid upto (date) and
3. We are liable to pay the guaranteed amount or any part thereof under this bank guarantee only and only if HCSL serve upon us a written claim or demand on or before.....(validity date).

Any demand for payment under this guarantee must be received by us at this office during working hours on or before the validity date. Should we receive no claim from you by the validity date, our liability to you will cease and the guarantee will definitely become null and void whether returned to us or not.

Yours truly,

Signature and seal of the guarantor:.....

Name of Bank:.....

Address:.....Date:.....

[\[1\]](#)An amount shall be inserted by the Guarantor, representing the percentage of the Contract Price specified in the Contract and denominated in respective Dollars / Indian Rupees/Other Currency.

Self-Declaration to be given by the bidder in Letter head

Bid's Reference No. & Date:

Bidder's Name & Address:

Person to be contacted:

Designation:

Telephone No.:

Fax No.:

Email:

1. We do hereby declare that we have not been debarred/black listed by HCSL or by any of the Public Sector Undertaking or Government department etc.

2. If HCSL finds that, we have been blacklisted/ debarred by any of the Public Sector Undertaking or Government department, and then HCSL can reject the offer or terminate the contract at any point of time. In such case, we are aware that, EMD, security deposit, performance guarantee etc will be forfeited by HCSL. Further we are confirming herewith that, any loss that has happened to HCSL due to this will be compensated by us.

For and on behalf of the firm

(Firms Name & Address)

(Signature of Authorized Signatory)

Name:

Designation

Phone No.:

Seal:

Date:

Place:

Form of Legal Case (Sample Format)

Details of legal cases pending against the firm for the last five years

SL. NO.	ORGANISATION AGAINST WHOM THE LITIGATION IS INVOLVED	BRIEF DETAILS OF DISPUTE	AMOUNTS INVOLVED (Rs.)	PRESENT STATUS	Remarks

- If no Cases pending please mention as “NIL” and submit the above form.

SIGNATURE OF BIDDER

Annexure-14

Tender conditions for Restriction of bidders sharing land border with India vide Office memorandum dt 23.7.2020 Order Public Procurement no 1 dt 23.7.2020, Order no 2 dt 23.7.2020, Order no 3 dt 24.7.2020 and amendments issued by GOI time to time.

A	Requirement of registration
1	Any bidder from a country which shares a land border with India will be eligible to bid in this tender only if the bidder is registered with competent authority as per C below. In works contracts, including turkey contracts, contractors shall not be allowed to subcontract works to any contractor from a country which shares a land border with India unless such contractor is registered with Competent authority. Relevant certificate to be submitted by bidder from a country which shares land border with India except for bidders to which Govt of India has extended lines of Credit or in which Govt of India has development projects, along with the offer as proof of registration with competent authority, failing which the offer will not be considered. A certificate is to be submitted by the bidder for compliance with the order referred above along with tender documents for consideration of offer (Wordings are as per Clause below). If such certificate given by a bidder whose bid is accepted is found to be false, this would be a ground for immediate termination and further legal action in accordance with law.
2	Wordings of certificate to be submitted along with tender documents
	I have read the clause regarding restrictions on procurement from a bidder of a country which shares a land border with India. I hereby certify that this bidder is not from such a country or, if from such a country, has been registered with the competent authority. I hereby certify that this bidder fulfils all requirements in this regard and is eligible to be considered. (Evidence of valid registration by the competent authority shall be attached wherever applicable)
2	Wordings of certificate to be submitted along with tender documents for Works Involving possibility of subcontracting
	I have read the clause regarding restrictions on procurement from a bidder of a Country which shares a land border with India and on subcontracting to contractors from such countries. I certify that this bidder is not from such a country or if from such a country has been registered with the competent authority and will not sub contract any work to a contractor from such countries unless such contractor is registered with the competent authority. I hereby certify that this bidder fulfils all requirements in this regard and is eligible to be considered (Evidence of valid registration by the competent authority shall be attached wherever applicable)
B	Validity of registration

1	Registration should be valid at the time of submission of bids and at the time of Acceptance of bids. In respect of supply otherwise than by tender, registration should be valid at the time of placement of order. If the bidder is validly registered at the time of acceptance /order placement, registration shall not be a relevant consideration during contract execution.
C	Competent authority and Procedure for registration
1	The competent authority for the purpose of registration under the order shall be Registration committee constituted by the Department of Promotion of Industry and Internal Trade (DPIIT). Details of the committee and procedure for registration and restrictions shall be as per Ann I of the Order – Public Procurement no 1 dt 23.7.2020 issued by Ministry of Finance, department of Expenditure.
D	Definition of Bidder and Bidder from a country sharing land border with India
1	Bidder is defined as any person or firm or company including any, member of a consortium or joint venture, every artificial, juridical person not falling in any of the descriptions of bidders stated here in before, including any agency, branch or office controlled by such person, participating in a procurement process.
2	"Bidder from a country which shares a land border with India “for the purpose of this Order means: – a) An entity incorporated, established or registered in such a country; or b) A subsidiary of an entity incorporated, established or registered in such a country; or c) An entity substantially controlled through entities incorporated, established or registered in such a country; or d) An entity whose beneficial owner is situated in such a country; or e) An Indian (or other) agent of such an entity; or f) A natural person who is a citizen of such a country; or g) A constitution or joint venture where any member of the consortium or joint venture falls under any of the above.
3	Type of business entity (Private Limited Company / Public Limited Company / Sole Proprietorship / One Person Company / Partnership / Limited Liability Partnership / Joint Venture / Trust/ NGO) In case of incorporated entity–to attach certificate of incorporation
	Beneficial Owners –as defined in the Department of Expenditure Order (Public Procurement No.1) issued vide No. F.No.6/18/2019–PPD dated 23 rd July, 2020.Details of all beneficial owners having entitlement of more than 01% of shares or Capital or profit to be given, in the format as given in Annexure–I duly certified by Practicing Chartered Account in India.

Tender condition- Preference to Make in India	
A	Purchase preference in accordance with Public procurement (Preference to Make in India Order – 2017) Order from Department of Promotion of Industry and Internal Trade P-45021/2/2017/-B.E-IIdt,4.6.2020 and as amended from time to time shall be applicable as per below
1	In the procurement of all goods/services/works in respect of which there is sufficient local capacity /local competition, only Class I Local suppliers shall be eligible to bid irrespective of purchase value
2	In the procurement of all goods/services /works which are not covered as above and with estimated value of purchase less than Rs 200.0 Crores, only Class I local Suppliers along with Class II local suppliers shall be eligible to bid.
Purchase preferences for Class I local suppliers	
B	In the procurement of goods/works covered under 2 above and which are divisible in nature, Class I local supplier shall be eligible for Purchase preference over Class II / Non local supplier as per following
1	If L1 bid is not a Class I local supplier, 50% of the order quantity shall be awarded to L1. Thereafter the lowest bidder among Class I local supplier will be invited to match the L1 price for the remaining 50% quantity subject to Class I local supplier quoted price falling within 20% margin. Contract for that quantity shall be awarded to such Class I local supplier subject to matching L1 price. In case such lowest eligible Class I local supplier fails to match L1 price or accept less than offered quantity, next higher Class I local supplier within 20% margin shall be invited to match the L1 price for the remaining qty and so on. If some quantity is left uncovered on Class I local supplier, such balance quantity shall be ordered on L1 bidder.
2	For procurements that are not divisible in nature and in procurement of services evaluated on price alone, Class I local supplier shall get purchase preference over Class II/Non local supplier as per below
3	If L1 is not a Class I local supplier, lowest bidder among Class I local supplier will be invited to match L1 price subject to Class I local supplier quoted price falling within 20% of L1 price and contract will be awarded to such Class I local supplier, subject to matching L1 price. In case such lowest eligible Class I local supplier fails to match L1 price, procedure same as para 3 above will be opted. In case none of Class I local suppliers within 20% margin matches L1 price, contract shall be awarded to L1 bidder. The purchase preference as above will be only for Class I local supplier and Class II local supplier will not be eligible for any Purchase preference
C	Local content requirement to categories a supplier as Class I/Class II/Non local supplier shall be as per below. Definition of local content shall be as per order dt 4.6.2020 i.e amount of value added in India which shall be the total value of the item procured (excluding net domestic indirect taxes) minus the value of import content in the item (including all customs duties) as a proportion of total value in percentage.
1	Class I–Local content equal to or greater than 50%
2	Class II–Local content greater than 20%, less than 50%
3	Non local–Local content less than 20%
D Declaration of local content	
	Class I local supplier /Class II local supplier at the time of tender shall indicate % of local

1	content and provide self-certification that offered item shall meet the local content requirement for Class I/Class II as applicable including details of locations at which local value addition is made.
2	In case of procurement for a value in excess of Rs 10.0 Crores Class I/Class II local supplier is to provide a certificate from statutory auditor/cost auditor (for companies) /practicing cost accountant/ Chartered accountant (suppliers other than companies) indicating % of local content
3	Verification of the Certificates issued by the bidder shall be carried out by HCSL on random basis. False declarations will attract actions as stipulated in the order referred, including other actions as permissible by law.
4	Exemption is applicable from provisions of order for purchases with estimated values less than Rs 5.0 lakhs
5	Notwithstanding above, exemptions for meeting local content as per relevant Clause of order dt 4.6.2020 and as amended from time to time shall apply.

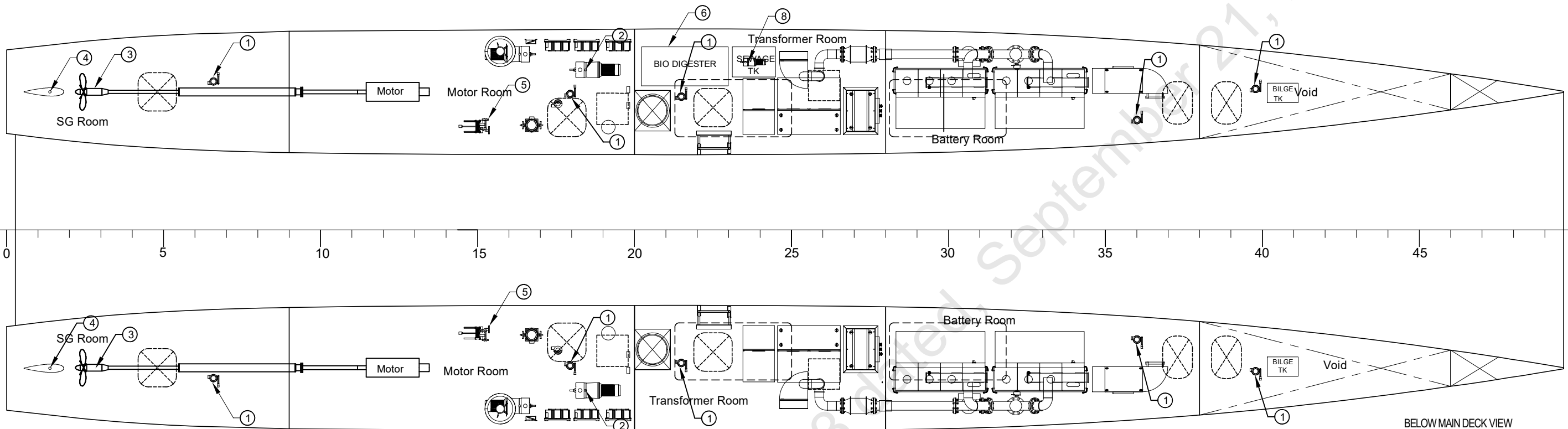

BELOW MAIN DECK VIEW

POS. NO	EQUIPMENT	QTY
1	BILGE PUMP	10
2	FIRE PUMP	2
3	FPP SHAFTING SYSTEM WITH MOTOR	2
4	RUDDER WITH STEERING GEAR SYSTEM	2
5	HEAT EXCHANGER FOR V.F.D.	2
6	BIODIGESTER	1
7	PORTABLE BILGE PUMP ALSO ACT AS 'BILGE SHORE DISCHARGE PUMP'	1
8	SEWAGE SHORE DISCHARGE PUMP	1

MAIN PARTICULARS

LENGTH O.A.....	abt 24.80[M]
BREADTH (MLD).....	abt 6.40 [M]
DEMI HULL BREADTH.....	abt 2.00 [M]
DEPTH (MLD).....	abt 1.70 [M]
DRAFT (MLD).....	abt 0.90 [M]
ECONOMIC SPEED	7 KNOTS
MAX. SPEED	9 KNOTS
PASSENGER CAPACITY	50 NOS.
CLASS NOTATION	IRS

5W1L, 5Y1, ZONE2, FERRY, BATTERYPROP

SEE LETTER E-196997-260883



Rev.1	27-Jul-2023	Modified as Design progress	Govind	Rakes	Nibin
Rev.0	25-Apr-2023	Contract Design	Asahaf	Shakkir/Binoy	Jathesh
No:	Date	Description	Drawn	Checked	Approved
CUSTOMER			50 PAX HYBRID ELECTRIC CATAMARAN FERRY		
INLAND WATERWAYS AUTHORITY OF INDIA			TITLE		
Yard Nos.: TBD			Machinery Arrangement - Below Main Deck (Preliminary)		
COCHIN SHIPYARD LIMITED			1:65	A3	P191
P.O. Bag 1653, COCHIN-682015, INDIA			Scale	Format	Project No.
P191-104-007			Dwg. no.		

ACCORDING TO INTERNATIONAL LAWS, THIS DRAWING IS THE PROPERTY OF COCHIN SHIPYARD LTD. THE DRAWING CAN NOT BE MADE PUBLIC, COPIED OR OTHERWISE USED, WITHOUT WRITTEN CONSENT.

SHAFT ARRANGEMENT

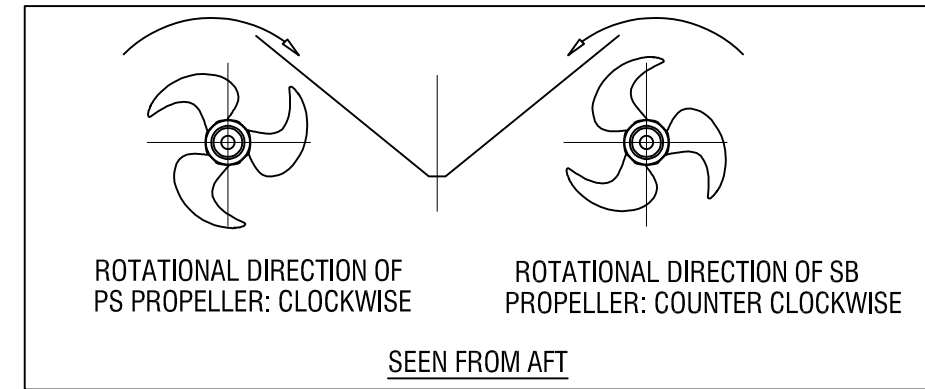
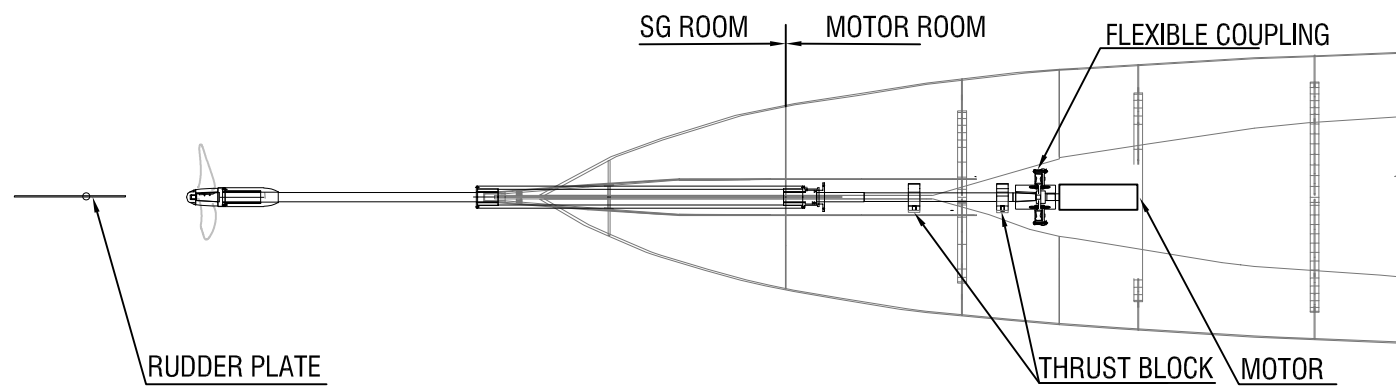
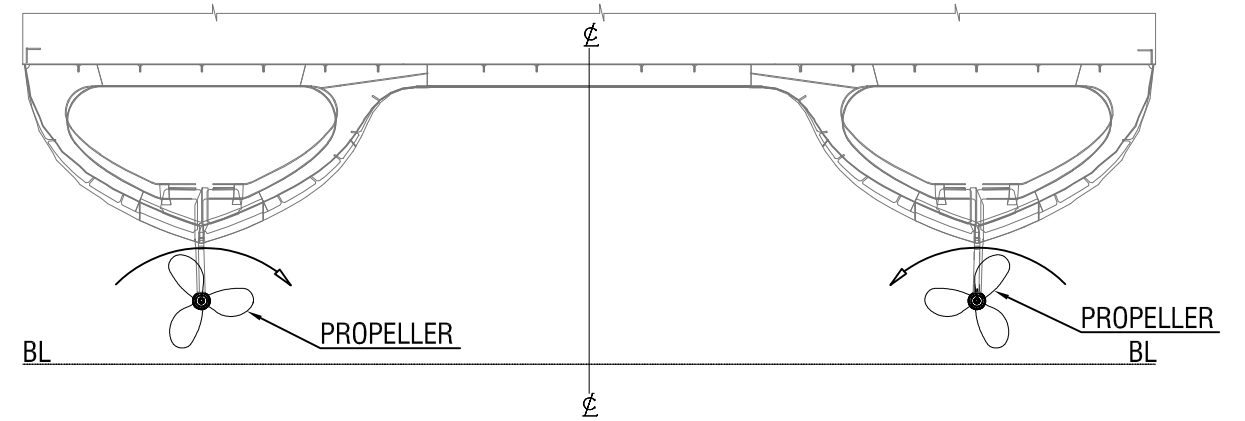
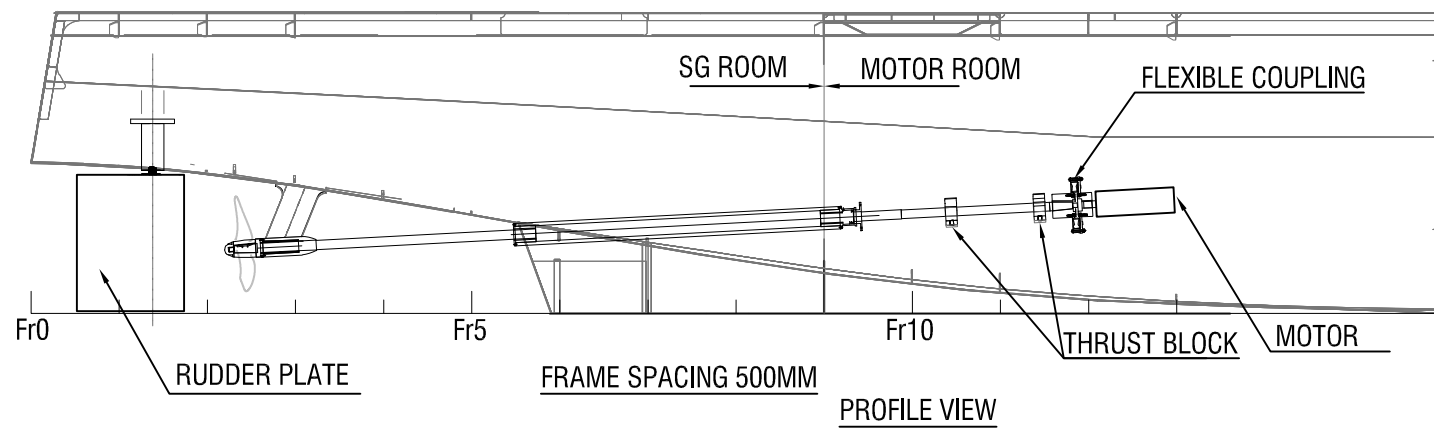

NOTES

CLASSIFICATION AND REGULATIONS	CLASS ID No.	—
	CLASS NOTATION:	IRS: 𑌛IWL, ZONE 2, FERRY, 𑌛IY, BATTERY PROP,
	NATIONAL AUTHORITIES:	INDIA
	FLAG:	INDIA



MAIN PARTICULARS

LENGTH O.A.....	abt 24.80[M]
BREADTH (MLD).....	abt 6.40 [M]
DEMI HULL BREADTH.....	abt 2.00 [M]
DEPTH (MLD).....	abt 1.70 [M]
DRAFT (MLD).....	abt 0.90 [M]
ECONOMIC SPEED	7 KNOTS
MAX. SPEED	9 KNOTS
PASSENGER CAPACITY	50 NOS.
CLASS NOTATION	IRS
	𑌛IWL, 𑌛IY, ZONE2, FERRY, BATTERYPROP

Rev.0	27-Apr-2023	Contract Design	Asahaf	Shakkr/ Binoy	Jathesh
No:	Date	Description	Drawn	Checked	Approved
CUSTOMER		50 PAX HYBRID ELECTRIC CATAMARAN FERRY			
INLAND WATERWAYS AUTHORITY OF INDIA		TITLE PRELIMINARY SHAFT ARRANGEMENT			
Yard Nos.: TBD		Scale	Format	Project No.	Dwg. no.
COCHIN SHIPYARD LIMITED		1:95	A3	P191	P191-620-001
P.O. Bag 1653, COCHIN-682015, INDIA					1 of 2
					Sheet No

ACCORDING TO INTERNATIONAL LAWS, THIS DRAWING IS THE PROPERTY OF COCHIN SHIPYARD LTD. THE DRAWING CAN NOT BE MADE PUBLIC. COPIED OR OTHERWISE USED, WITHOUT WRITTEN CONSENT.

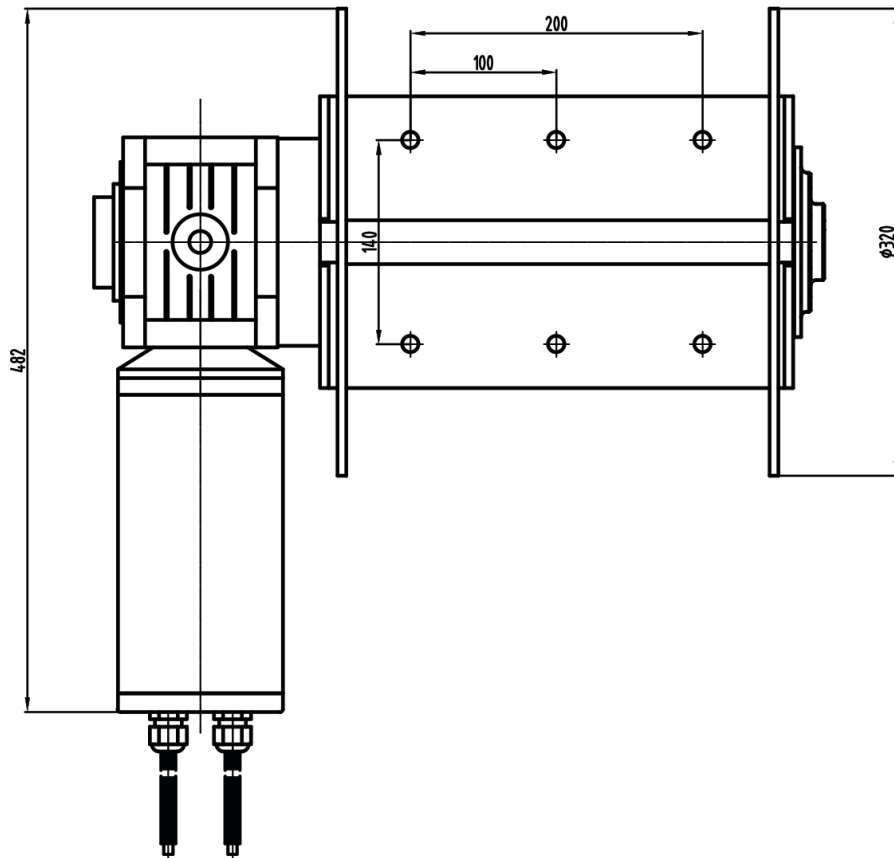
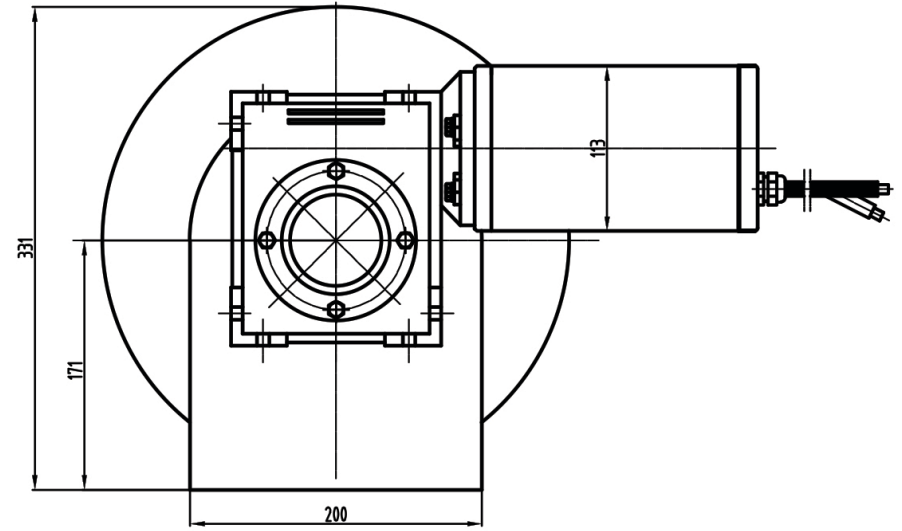
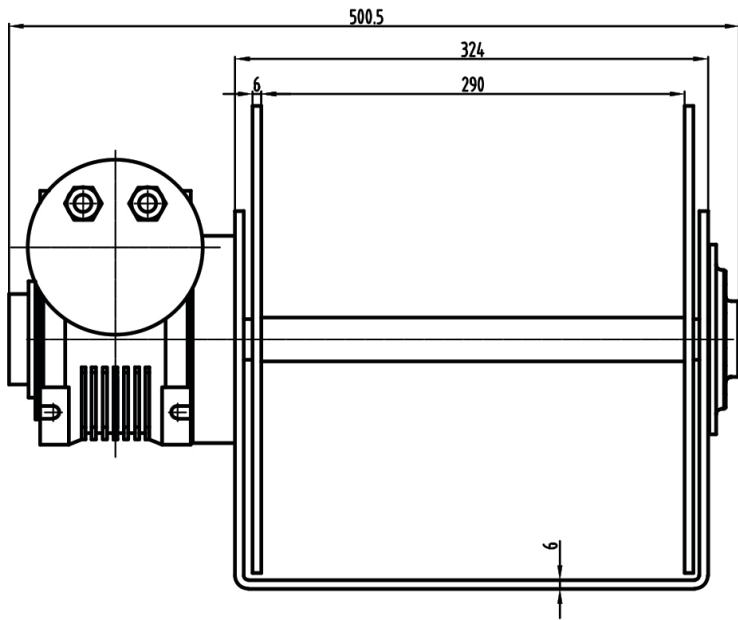

Anchor Winch & Motor