

**TENDER NOTICE**

सीएसएल – कोलकाता पोत मरम्मत यूनिट (सीकेएसआरयू), कोलकाता की ओर से निम्न सूचित कार्य के लिए अनुभवी फर्मों से मुहरबंद प्रतिस्पर्धी निविदाएं आमंत्रित की जाती हैं, ताकि निम्न सूचित तिथि और समय पर या उससे पहले अधोहस्ताक्षरी तक पहुँच सकें। कृपया संलग्न तकनीकी विनिर्देश, सामान्य नियम और शर्तें एवं अन्य अनुदेशों का संदर्भ लें।

Sealed competitive tenders are invited on behalf of CSL-Kolkata Ship Repair Unit (CKSRU), Kolkata from experienced firms for the under mentioned work, so as to reach the undersigned on or before the date and time mentioned below. Please refer to the Technical Specification, General Terms and Conditions and other instructions attached.

निविदा सं. व तिथि Tender No. & date	सीएसएल/सीकेएसआरयू/ टीईएन/692/2026-27 दिनांक 10/07/2026 CSL/CKSRU/TEN/692/2026-27 dated 10/07/2026
कार्य का नाम Name of Work	सीकेएसआरयू कोलकाता के लिए मंचन सामग्री की खरीद (विस्तृत विनिर्देश अलग से संलग्न है)  PROCUREMENT OF STAGING MATERIALS FOR CKSRU, KOLKATA (DETAILED SPECIFICATION IS ENCLOSED SEPARATELY)
निविदा का प्रकार Type of Tender	<b>दो बोली</b> <b>Two Bid</b>
जमा करने के लिए बयाना राशि Earnest Money to be deposit	₹. 10,000/- Rs.10,000/-
निविदा प्रपत्र की लागत Cost of Tender Form	शून्य NIL
निविदा प्राप्ति की अंतिम तिथि एवं समय Last date & time of receipt of tender	दिनांक 27/07/2026 को 16:00 बजे तक 27/07/2026 up to 16:00 hrs
निविदा खोलने की तिथि एवं समय Date & time of opening of tender	दिनांक 27/07/2026 को 16:30 बजे तक 27/07/2026 at 16:30 hrs
कार्य पूर्ण करने की अवधि। Work completion period	<b>16 सप्ताह</b> (कार्य आदेश की स्वीकृति की तिथि से) <b>16 Weeks</b> (from the date of acceptance of work order)





लिफाफे के ऊपर निविदा संदर्भ स्पष्ट रूप से सूचित किया जाना चाहिए।

Tender reference should be clearly indicated on top of the envelope.

उप महाप्रबंधक (सीकेएसआरयू) को संबोधित मुहरबंद निविदाएं सीएसएल- कोलकाता पोत मरम्मत यूनिट (सीकेएसआरयू), ड्राई डॉक ऑफिस बिल्डिंग, गेट नं. 9, नेताजी सुभास डॉक, सर्कुलर गार्डन रीच रोड, कोलकाता - 700024 में स्थित 'सीकेएसआरयू निविदा बॉक्स' में नियत तारीख एवं समय तक डाली जाएंगी।

Sealed tenders addressed to The Asst General Manager (i/c) (CKSRU) shall be dropped in the "CKSRU Tender box" located at CSL-Kolkata Ship Repair Unit (CKSRU), Dry Dock Office Building, Gate No. 9, Netaji Subhas Dock, Circular Garden Reach Road, Kolkata -700024 by the due date and time.

उपरोक्त कार्य के लिए प्रभारी अधिकारी  
Officer In-Charge for the above work

नाम/ Name : सुधीर रांडवा/Sudhir Randwa  
पदनाम/ Designation: सहायक प्रबंधक/Assistant Manager  
संपर्क सं. (मोब.)/Contact No (M): 9174420344  
ई-मेल/ E-mail: sudhir.randwa@cochinshipyard.in

कृते कोचीन शिपयार्ड लिमिटेड  
For Cochin Shipyard Limited

For

ठेकेदार का हस्ताक्षर एवं मुहर  
Signature and Seal of the Contractor (s)

सहायक महाप्रबंधक (सीकेएसआरयू)  
Assistant General Manager (CKSRU)



## TABLE OF CONTENTS

<b>Sl. No.</b>	<b>Description</b>	<b>Annexure</b>
1	Scope of Work & Technical Specification	1
2	Price bid	2
3	General terms and conditions	3
4	Special Instructions for Two-Bid systems	4
5	Vendor Details	5

**Annexure 1****SCOPE OF SUPPLY AND TECHNICAL SPECIFICATION**

The scope of work includes supply of below listed items at CKSRU, Kolkata.

S.No.	Item	Description	Qty
1	VERTICALS FOR STAGING- 3,000 MM	Verticals shall be made of 40 NB Heavy Class continuous welded steel tubes conforming to IS: 1239, Heavy Class or equivalent and have 5 mm thick sockets welded at 50 cm centre for fixing Transoms or Ledgers. Each vertical shall have specially designed captive expanding joint (hollow wedges of 5 mm thickness) working on wedge principles for connecting the vertical together. Verticals are to be applied with one (1) coat of epoxy Red Oxide Primer and two (2) coats of epoxy anticorrosive paint of Dark Grey from reputed manufacturers. Surface preparation by pickling/ phosphating to be carried out. Pickling and phosphating are to done as per IS standard. To ensure quality, inspection and testing procedure as per IS-3618 will be followed. The procedure & method of pickling / phosphating is to be submitted by the supplier along with quotation.	100 Nos.
2	LEDGERS FOR STAGING- 2,445 MM	Ledgers shall be fabricated with Welded Steel Tubes 40 NB Light Class of the required length. Either ends of the ledgers shall have captive wedges of 8 mm thick to facilitate connection to the verticals. Ledgers are to be applied with one (1) coat of epoxy Red Oxide Primer and two (2) coats of epoxy anticorrosive paint of Dark Grey from reputed manufacturers. Surface preparation by pickling/ phosphating to be carried out. Pickling / phosphating are to done as per IS standard. To ensure quality, inspection and testing procedure as per IS-3618 will be followed. The procedure & method of pickling / phosphating is to be submitted by the supplier along with quotation.	100 Nos.
3	TRANSOM FOR STAGING 1,195 MM	Transoms shall be fabricated with 50 x 50 x 6 mm MS Angles. Either ends of the transoms shall have captive wedges of 8 mm thick to facilitate connection to the verticals. Transoms are to be applied with one (1) coat of epoxy Red Oxide Primer and two (2) coats of epoxy anticorrosive paint of Dark Grey from reputed manufacturers. Surface preparation by pickling/ phosphating to be carried out. Pickling / phosphating is to done as per IS standard. To ensure quality, inspection and testing procedure as per IS-3618 will be followed. The procedure & method of pickling / phosphating is to be submitted by the supplier along with quotation.	750 Nos.

4	GI STAGING BOARD (50X225X2460 MM)	Staging Boards shall be made out of MS Sheets as per IS: 513:2008 of thickness 16-gauge, sectional size of 50 x 225 mm and length of 2,460 mm. The bottom edge of the boards is to be bent about 25 mm towards inside. Steel Boards are to be press bent with anti-skid dimples on top of the boards. Five (5) Nos. stiffeners shall be provided under the boards at equal spacing and enclosing both ends. Post manufacturing, each staging board has to be hot dip galvanized as per IS 4736 and a minimum & uniform Zinc deposition as per IS 4736 has to be ensured.	350 Nos.
5	SWIVEL CLAMP (40 MM x 40 MM, MS GALVANISED)	To join scaffold tubes together securely, BS1139/EN74 Drop Forged	100 Nos.
6	RIGHT ANGLE CLAMPS (MS GALVANISED)	To join two scaffolding pipes at a precise 90-degree angle, BS1139/EN74 Drop Forged	100 Nos.
7	STAGING LADDER	Staging Ladder 3,000 mm long (25 NB 'B' Class Pipes) with 10 Nos. rungs (20 NB 'B' Class pipes) and hooks as per sketch attached (Ref: Encl 1). Post manufacturing, each staging ladder has to be hot dip galvanized as per IS 4736 and a minimum & uniform Zinc deposition as per IS 4736 has to be ensured.	100 Nos.

**Note:****(1) Raw materials:**

- a) All the Raw materials used for the fabrication of staging materials to be sourced from reputed makes like TATA, Jindal, SAIL, Utkarsh, APL Apollo, Nippon Tubes Ltd, Surya Roshni etc.,
- b) Paints to be procured from reputed makes like Jotun, AkzoNobel, Berger, Nerolac and Asian Paints.
- c) Manufacturer Test Certificates (MTC) are to be provided for CSL records.

**(2) Inspection:**

Raw materials shall be presented for inspection by CSL/CKSRU Representative prior to commencement of fabrication. Fabricated items shall also be presented for further inspections prior to painting and before dispatch. Stage, final and receipt inspection at shipyard, of the items will be carried out as per the discretion of CSL/CKSRU. All the relevant test certificates of Raw materials and final deliverables to be submitted during the inspection.

**(3) Sample:**

All items shall be fabricated as per the samples provided by CSL/CKSRU. Sample to be collected by the contractor from CKSRU at their own cost. Identical parts shall be

fabricated ensuring dimensional similarity such a way that it's easy to inter-change while using.

- (4) **Location of supply:** Cochin Shipyard Limited  
CSL-Kolkata Ship Repair Unit  
Gate No. 9, Netaji Subhas Dock  
Circular Garden Reach Road,  
Kolkata – 24.

- (5) **Ref Encl. 1 for detailed drawing / description.**

(6) **Eligibility Criteria**

In order to ensure better participation and competitive offer, it is proposed to float tender in open tender mode. Tender shall be published in CSL and Govt. website accordingly. The minimum eligibility criteria considered for this tender are as detailed below.

- i. Experience having successfully completed the manufacturing and supply of scaffolding materials during the last 7 years ending last day of month previous to the one in which tenders are invited should be either of the following:
- a) Three similar completed works (Manufacturing & supply of scaffolding materials) each costing not less than the amount equal to Rs.12 Lakhs.  

OR
  - b) Two similar completed works (manufacturing and supply of scaffolding materials) each costing not less than the amount equal to Rs.15.5 Lakhs.  

OR
  - c) One similar completed work (manufacturing and supply of scaffolding materials) costing not less than the amount equal to Rs.24 Lakhs.  
(Details of orders executed along with completion certificate from the client indicating value of work executed and performance shall be submitted in this regard. The similar work should have been executed in India.).
- ii. The bidder should have an average annual turnover of Rs.10 Lakhs in the last 3 FYs (FY23, FY24 & FY25).

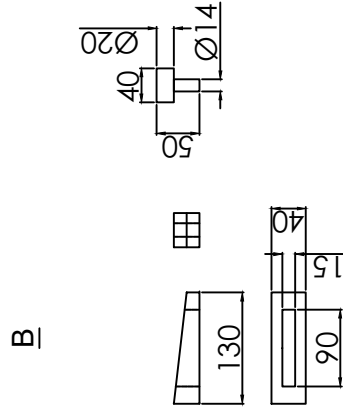
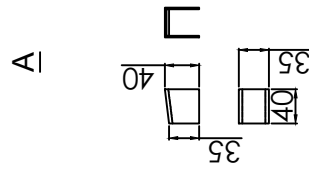
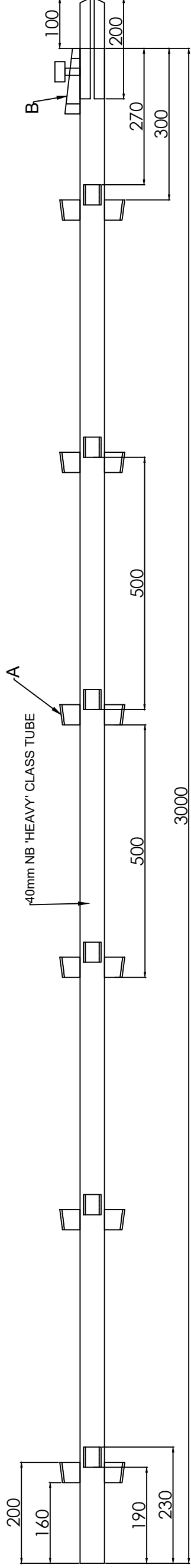

Issued for : Fabrication					
Project: Staging Material Drawings					
Dwg No.	Rev.	Drawing Title:			
CSL-SD-D.NO-SM-03	00	Standard - 3m			
Date	Sheet				
31-06-2024	1 of 1	Drawn	CSL		

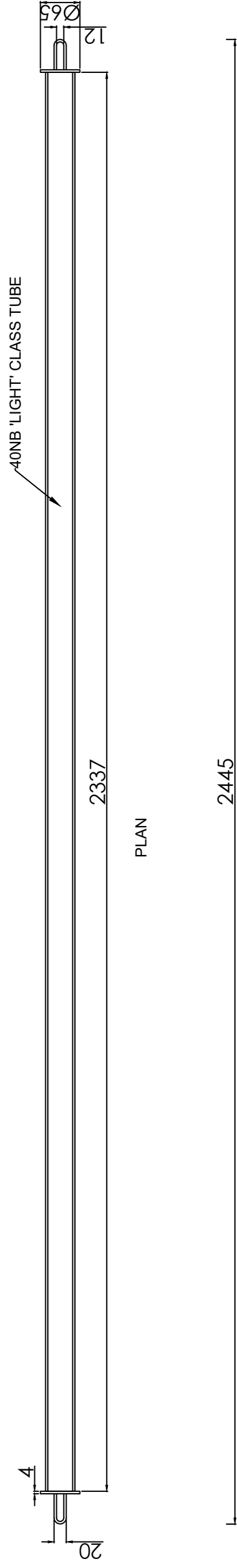

PLAN

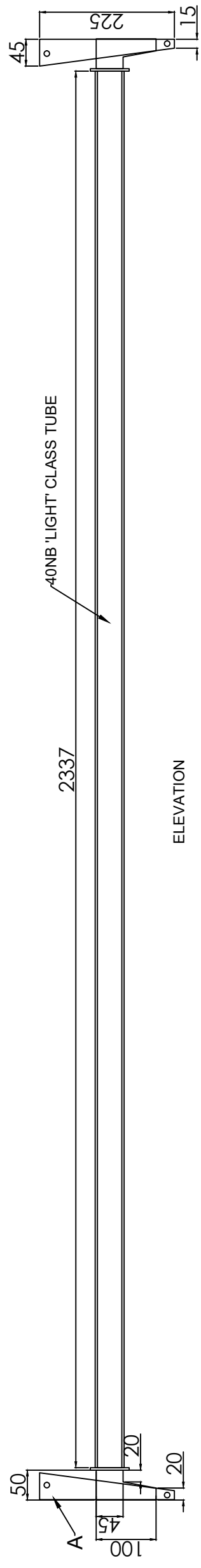

ELEVATION

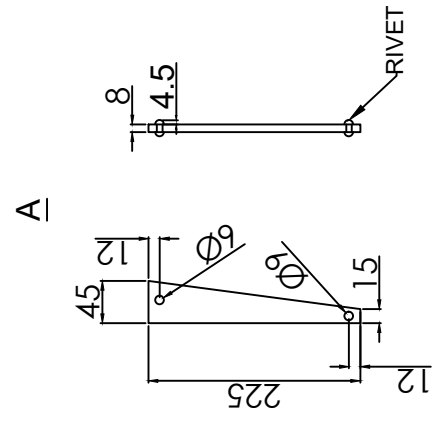

Issued for : Fabrication

Project: Staging Material Drawings

Dwg No.	Rev.	Drawing Title:	Drawn	CSL
CSL-SD-D.NO-SM-01	00	WedgeLock Ledger - 2.5m		
Date	Sheet			
31-06-2024	1 of 1			

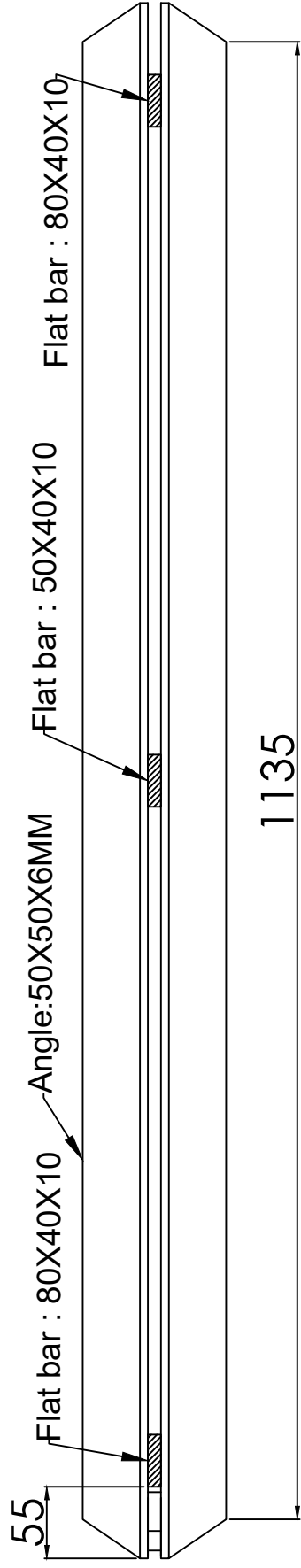
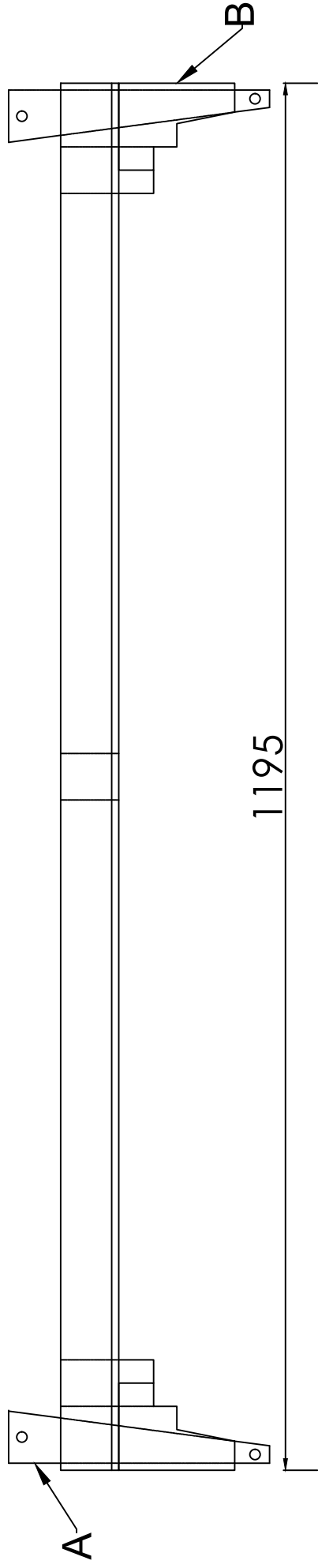

A

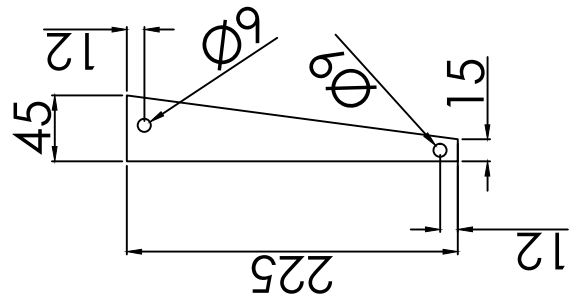

B

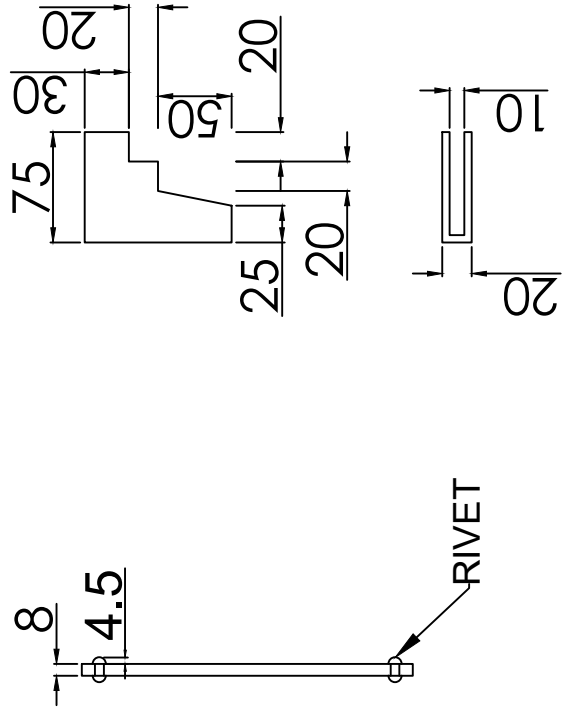

Issued for : Fabrication

Project: Staging Material Drawings

Drawing Title: Transom - 1.25m

Dwg No.	Rev.	Drawing Title:	Drawn	CSL
CSL-SD-D.NO-SM-02	00	Transom - 1.25m		
Date	Sheet			
31-06-2024	1 of 1			

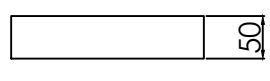
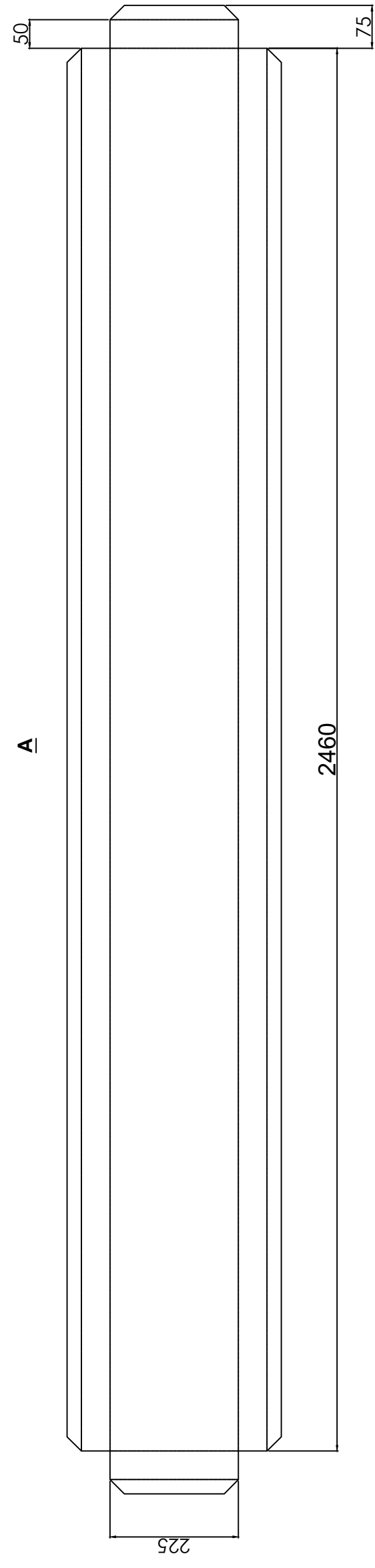
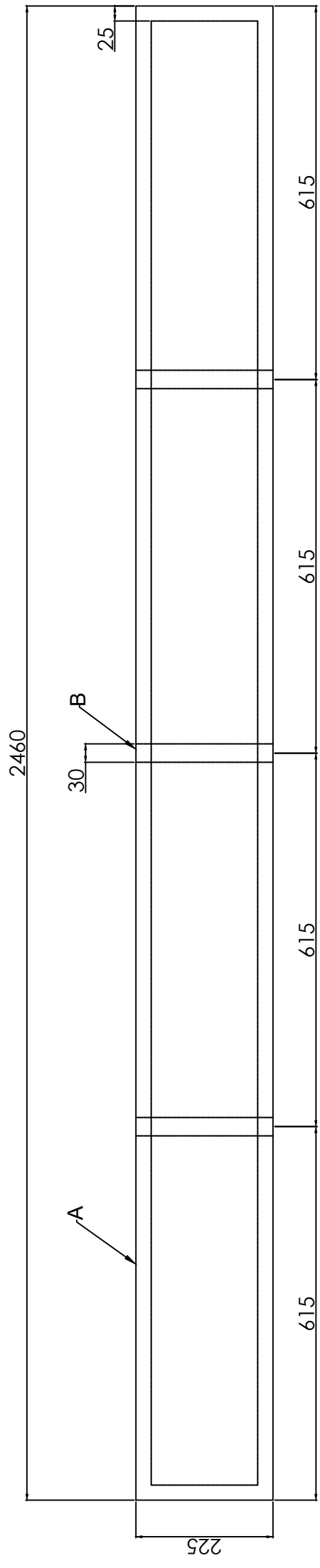

**B-Stiffener**

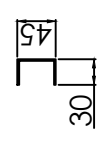
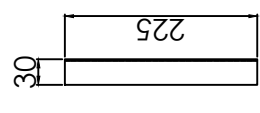

Project: Issued for : Fabrication			
Staging Material Drawings			
Dwg No.	Rev.	Drawing Title:	
CSL-SD-D.NO-SM-04	00	Staging Board - 2.5m	
Date	Sheet	Drawn	CSL
31-06-2024	1 of 1		

Encl-1

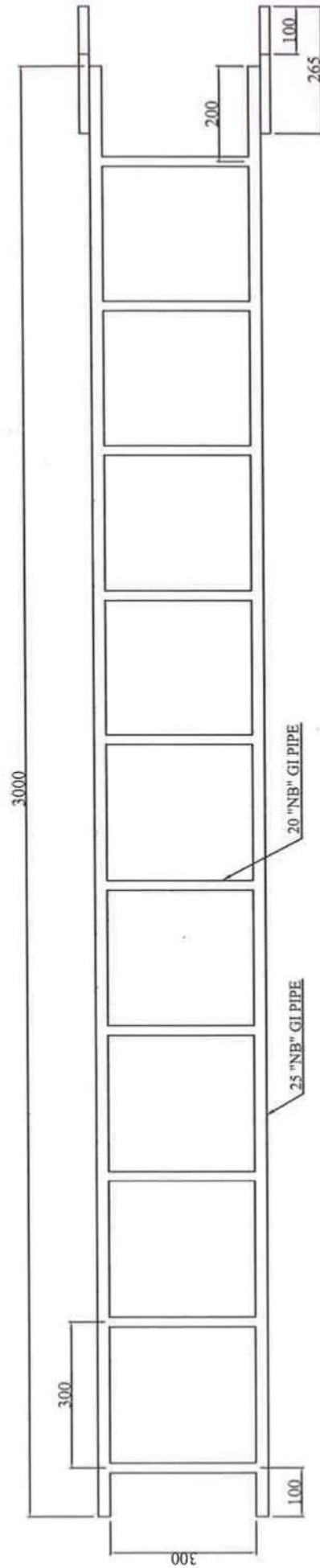
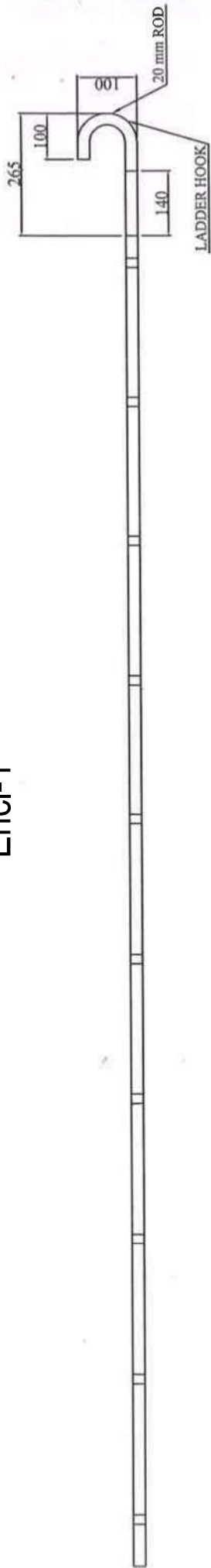

**SWIVEL CLAMP (40 MM x 40 MM, MS GALVANISED)**



**RIGHT ANGLE CLAMPS (MS GALVANISED)**

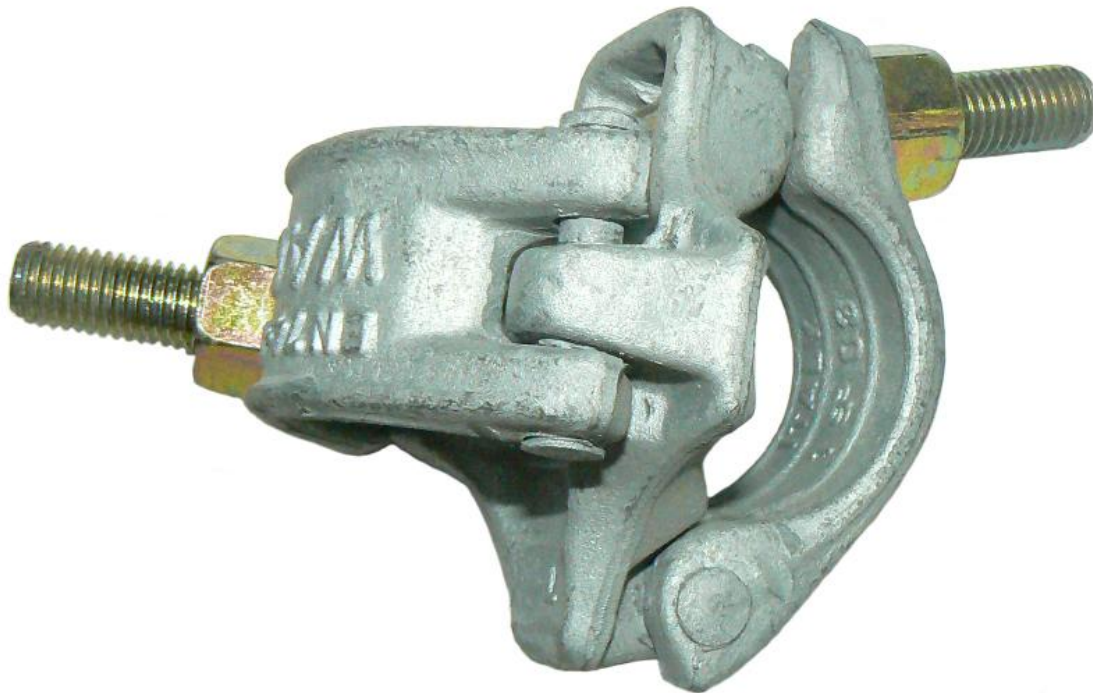

## PRICE BID

Annexure 2

Tender No. CSL/CKSRU/TEN/692/2026-27 dated 10/07/2026

Name of work: Procurement of Staging materials for CKSRU, Kolkata

SI No	Item description	Qty (A)	UoM	Unit rate Excl GST (Rs) (B)	Total rate Excl. GST (Rs) (C=AxB)	GST(%)	HSN Code
1	VERTICALS FOR STAGING-3,000 MM (As per technical specification at Annexure 1)	100	Nos.				
2	LEDGERS FOR STAGING-2,445 MM (As per technical specification at Annexure 1)	100	Nos.				
3	TRANSOM FOR STAGING 1,195 MM (As per technical specification at Annexure 1)	750	Nos.				
4	GI STAGING BOARD (50X225X2460 MM) (As per technical specification at Annexure 1)	350	Nos.				
5	SWIVEL CLAMP (40 MM x 40 MM, MS GALVANISED) (As per technical specification at Annexure 1)	100	Nos.				
6	RIGHT ANGLE CLAMPS (MS GALVANISED) (As per technical specification at Annexure 1)	100	Nos.				
7	STAGING LADDER (As per technical specification at Annexure 1)	100	Nos.				
<b>Total amount (Excluding GST) (INR)</b>							
<b>Total amount (Including GST) (INR)</b>							

Signature and seal of the bidder

**TERMS AND CONDITIONS**

1. Tenderers are to carefully go through the terms and conditions and the technical specification of the items for which offers are called for
2. Offer shall be submitted in the prescribed form in the 'CKSRU Tender Box' located at CSL-Kolkata Ship Repair Unit, Gate No.9, Netaji Subhas Dock, Circular Garden Reach Road, Kolkata - 700024, and has to be addressed to The AGM (CKSRU), Cochin Shipyard Limited, CSL-Kolkata Ship Repair Unit, Kolkata - 24.
3. In case of bid sent through e-mail, then the documents should be password protected and the passwords should be passed on to the concerned officer while attending the bid opening or by e-mail or SMS immediately before the tender opening against the request from concerned officer.
4. **Validity:** The offer should be valid for a minimum period of four months from the date of submission of an offer.
5. **Earnest Money Deposit (EMD):**Rs.10,000/- (Rupees Ten Thousand only)  
EMD for a valid bid has to be submitted by the bidder in the form of demand draft / FDR / Bank Guarantee (Annexure 18) drawn in favour of Cochin Shipyard Limited from scheduled bank except Co-operative bank in case of indigenous bidders and from international bank as per the CSL approved list in case of foreign bidder. Cheques are not acceptable. Bids submitted without EMD will be rejected. No interest shall be paid for the EMD, Security Deposit or Performance guarantee. EMD will be returned to the unsuccessful bidders post finalization of tender and issue of Work Order to the L1 bidder.
6. **Cost of Tender Form:** Nil
7. **Mode of tender:**The tender for the work will be based on Two Bid system. The tender shall consist of below listed documents. Details are indicated at Annexure-4.
8. Bidders can contact Officer-in-Charge of the work which is indicated in the tendernotice for any clarification before submitting the offer. If clarifications/details are not obtained before the offer is submitted, no claim on this account will be admitted.
9. Bidders to note that no advance payment will be made by CSL against work order/ supply order issued.
10. Corrections and additions if any in the bid must be attested/ duly signed by the bidder. In the case of error in multiplication/addition in amount calculated, the unit rate quoted will be considered as correct and the amount will be calculated accordingly. Conditional rebates & discounts, incomplete/ambiguous offers are likely to be rejected.
11. L1 will be arrived based on the lowest total amount quoted for all the line items excluding GST.
12. No enhancement of rate for whatever cause will be allowed once the offer is accepted and an order is placed.
13. GST/Duties, if any, payable extra is to be indicated in the techno-commercial part for two bid.
14. **Delivery:** All the items as per the scope of work shall be delivered as per the tender conditions within 16 Weeks from the date of acceptance of order.
15. **Payment terms:**
  - a) Payment will be released after completion of supply of all items as per the Purchase Order and final acceptance by Officer-in-Charge after necessary deduction including Security Deposit if any. Original tax invoice should contain GST number of both parties and submit in triplicate.
  - b) Contractor shall indicate details like PAN, GST details etc. required for processing payment. Payments will be made through NEFT/RTGS/Cheque mode and necessary details shall be furnished by the contractor in the format at Encl-1.

- c) CSL reserves the right for the deduction of taxes and duties as applicable from the bill or invoice.
  - d) The invoice to be raised on Officer in-charge, Cochin Shipyard Limited, CSL-Kolkata Ship Repair Unit, Dry Dock Office Building, Netaji Subhas Dock, Gate No.9, Circular Garden Reach Road, Kolkata – 700024.
  - e) GST No. of CSL-Kolkata Ship Repair Unit is 19AAACC6905B1Z1.
  - f) Payment will be released tentatively within 30 days from the date of submission of bill duly certified by the authorized CSL representative at Kolkata. Delay of accepted bills will lead to delay in processing of payment.
16. The firm/bidder winning the contract shall sign an agreement with Cochin Shipyard Ltd for “Fall Clause”. Accordingly, during the contract period the firm/bidder cannot offer the item/s to anyone else at rates lower than the rates quoted, or the same lowest rate shall be applicable to the contract with CKSRU/CSL.
17. Manufacturer’s name, their trademark and brand, if any, should invariably be mentioned and illustrative leaflets giving technical particulars etc., should be attached to the offer.
18. Materials offered shall conform to CKSRU/CSL specifications and drawings.
19. Samples are to be supplied free of cost in the event of requirement by CKSRU/CSL. The detailed working drawing, if called for, is also to be furnished for approval before commencement of manufacture.
20. The quantities to be purchased may vary according to actual requirement at the time of placing orders.
21. MSME order dated 23rd March 2012, pertaining to public procurement policy is applicable to this tender also.
- The following benefits are extended for all the firms who are registered with district industries centre and come under the category of micro and small enterprises holding a valid Entrepreneurs Memorandum (EM) part ii certificate or Udyog Aadhaar Certificate. However, in order to avail the benefits as per public procurement policy for MSME's order, 2012, all
- a) MSE bidders are required to declare their Udyog Aadhar memorandum (UAM) number in Central Public Procurement Portal (CPPP) compulsorily.
  - b) Tender Forms Shall Be Issued Free of Cost.
  - c) For all firms who are registered with national small industries corporation (NSIC) and come under micro and small enterprises holding a valid NSIC certificate, the below benefit is also extended in addition to above.
  - d) Waiver of security deposit (SD) for the performance of the contract (3% of the order value by the way of bank guarantee till the supplies are completed), up to financial limit as mentioned in NSIC certificate. However, to ensure performance of the item during the guarantee period a performance bank guarantee (PBG) (3% of order value by the way of bank guarantee) to be submitted by the firm as applicable.
22. The rate quoted shall remain firm throughout the period including extension if any.
23. The firm should not subcontract the work in part or full.
24. **Guarantee Period:** The goods supplied shall be guaranteed for workmanship and satisfactory performance for a period of 12 months from the date of receipt of the materials at CKSRU yard and acceptance of the materials after receipt at CKSRU yard. Supplier should replace the defective materials without cost implication to CSL/CKSRU immediately after intimation of any such defects noticed during the Guarantee period.
25. **Security Deposit/ Bank Guarantee:**
- a) The successful bidder shall remit a security deposit of 3% of the total order value (excluding taxes, duties,) in the form of Bank Guarantee / demand draft drawn in favour of Cochin Shipyard Ltd towards the satisfactory performance of the contract, if an order is placed on them. Alternatively, a DD / Bank Guarantee

equivalent to above % of the total order value (excluding taxes, duties) as per CSL format from an International Bank as per approved list of banks available in CSL website (for overseas supplier) & Scheduled Indian bank for Indian supplier is to be submitted, if an order is placed towards satisfactory performance of the contract.

b) The Bank Guarantee /DD as above should be initially valid till 90 days after completion of supplies in terms of SD and later revalidated (within the validity of initial BG) to cover the guarantee period indicated plus 90days. Fixed Deposit Receipt (for equivalent amount of Security Deposit/WBG required as per tender) in lieu of bank guarantee is also acceptable. Fixed Deposit Receipt shall be in the name of supplier with lien marked in favour of Cochin Shipyard Limited, Kochi.

26. **Risk Purchase:** If the supplier fails to supply the items ordered within the delivery date or violate any of the terms and conditions of the purchase order, CSL/CKSRU shall have the following rights.

a) To terminate the contract with 15 days' notice forfeiting the security deposit.

b) To initiate alternate procurement action at the risk and cost of the supplier.

27. **Liquidated Damage:** In case any delay in completion period or in the Supply of ordered materials beyond the stipulated completion period / delivery period, the contractor has to pay Liquidated Damage (LD), a sum equivalent to ½% (half percentage) of the order value per week or part of the week subjected to maximum of 10 % of the order value.

28. **Force Majeure condition:** Should failure in performance of the contract or part thereof arise from war insurrection, restraint imposed by Government, Act of Legislature or other Statutory Authority or illegal strike, riot, legal lock-out, flood, fire, explosion, act of God or any inevitable or unforeseen event beyond human control which may be construed as reasonable ground for an extension of time, CSL may allow such additional time as is mutually agreed, to be justified by the circumstances of the case. The occurrence/cessation of force majeure situation is to be informed with documentary evidence within 15 days from the date of occurrence/cessation.

29. Transportation and Transit insurance shall be in the scope of supplier and unit prices quoted are to be inclusive of the same.

30. Packing Material should be eco-friendly.

31. Supplier should follow the statutory requirements of products offered.

32. Products supplied shall be nontoxic and harmless to health. In the case of toxic materials Material Safety Datasheet may be furnished along with the material.

33. After submission of tender, no unsolicited correspondence will be entertained.

34. Cochin Shipyard Limited does not bind itself to accept the lowest or any tender but reserves to itself the right to reject any or all or a part of any tender at its discretion.

**COCHIN SHIPYARD LIMITED  
CSL-KOLKATA SHIP REPAIR UNIT (CKSRU)  
KOLKATA – 700 024**

**SPECIAL INSTRUCTIONS FOR TWO BID SYSTEMS**

**1. MODE OF SUBMISSION OF TENDERS**

Tenders should be submitted in two separate sealed covers superscribed in capital letters as PART-I "TECHNO-COMMERCIAL" & PART-II "PRICE" indicating the tender number, due date and name & address of the tenderer.

**2. TECHNO-COMMERCIAL PART SHOULD CONTAIN FOLLOWING DETAILS**

- a. Technical specification & manufacturer's name and Model
- b. Documents for minimum eligibility criteria
- c. Drawings & Technical Literature
- d. Other conditions, if any
- e. Deviation list, if any
- f. Copy of unpriced Price bid (Price bid without price & with percentage of taxes & duties and details like quoted /Nil/Included need to be mentioned for each line item.)
- g. Complete set of tender documents duly signed and sealed on all pages as a token of acceptance.

**3. PRICE PART SHOULD CONTAIN FOLLOWING DETAILS**

- a. Duly filled price bid as per the tender document.
  - b. The quoted rate shall include rate for material, service engineer if required, transportation, loading etc. to deliver the items to the location as mentioned in the tender document.
4. CKSRU/CSL reserves the right to alter, modify the scope of supply at their discretion and consistent with the policy of the Government of India and statutory bodies under them as applicable to the contract from time to time.
5. The Techno-commercial part alone will be opened initially on the due date of tender. The price part will be opened only after evaluation of the Techno-commercial part. Firms will be intimated the date of opening of the price part, whose Techno-commercial bid is acceptable, in due course. Tenderers shall not be allowed to attend the Techno-commercial bid opening.
6. The Tenderer shall ensure that their Indian Agent is not representing any other suppliers for the same Tender. In other words, Indian Agents are not permitted to represent more than one firm for a particular Tender.
7. After submission of quotation / price opening, no unsolicited correspondence will be entertained.
8. Clarifications, either technical or commercial, should be submitted to points specially asked for only. The opportunity so given should not be used for correcting/changing/amending the data/conditions

already submitted with the tender.

9. Price part should be submitted in the Price Bid format provided. Price should be quoted separately for each item shown in the format. Combining of figures against more than one item and ambiguous clauses will lead to rejection of the bid. In case if there is any ambiguity in the price bid, unit rate quoted will be considered as base and L1 will be arrived accordingly.
10. Offers should be clear and unambiguous. Incomplete/ambiguous offers are likely to be rejected.



**Bank Certificate**

We certify that \_\_\_\_\_ has an Account No. \_\_\_\_\_ with us and we confirm that the details given above are correct as per our records.

Date:

Place:

(.....)  
Authorized official of Bank

**VENDOR DETAILS**

1	Name of the Bidder/Firm	
2	Registered office Address of Company/Firm	
3	Registered office Address of Company/Firm in Kolkata	
4	Telephone No./Fax No./Mobile No	
5	E-mail address	
6	Names of the contact person & designation	(i) (ii) (iii)
7	Type of Entity-Proprietorship/Partnership firm/Company/NSIC/MSME Category etc. (Please attach registration certificate of Firm/Partnership agreement/proprietorship documents)	
8	PAN Card Number	
	GST Registration Number (GST certificate to submitted along with the technical bid)	
	EPF registration no. (EPF registration certificate to be submitted along with the technical bid)  Note: In case firm does not have EPF registration reasons thereof to be indicated	
	ESI Registration No. (ESI registration certificate to be submitted along with the technical bid).  Note: In case firm does not have ESI registration reasons thereof to be indicated	
	Copy of License if applicable	
9	Whether the Agency has been blacklisted/debarred or given tender holiday or contract terminated before expiry of the contract period by any 'Govt./autonomous bodies/ organizations where bidder has provided services earlier due to deficiencies in service or misconduct etc.	Yes/No (please tick as applicable) If yes, please furnish details on a separate sheet

Sign &amp; seal of contractor: