



हुगली कोचीन शिपयार्ड लिमिटेड
(भारत सरकार का उद्यम)
HOOGHLY COCHIN SHIPYARD LIMITED
(A Govt. of India Enterprise)



वसुधैव कुटुम्बकम्
ONE EARTH • ONE FAMILY • ONE FUTURE

Tender No: HCSL/OPS/SB/TEN/2024/15, Dt.- 07.09.2024

NOTICE INVITING TENDER

Fabrication, Testing, Installation & Commissioning of Piping Systems for 50pax Hybrid Aluminum Catamaran Vessels (06 Nos.) being constructed at Hooghly Cochin Shipyard Ltd, Nazirgunge unit, Howrah

E-Sealed competitive tenders are invited on behalf of Hooghly Cochin Shipyard Limited (HCSL) from experienced vendors for the under mentioned work, so as to reach the undersigned on or before the date and time mentioned below. Please refer Scope of Work, General Terms and Conditions and Special Terms attached.

Tender No. & date	HCSL/OPS/SB/TEN/2024/15, Dt.- 07.09.2024
Scope of work	Fabrication, Testing, Installation & Commissioning of Piping Systems for 50pax Hybrid Aluminum Catamaran Vessels (06 Nos.) being constructed at Hooghly Cochin Shipyard Ltd, Nazirgunge unit, Howrah (Detailed specification is enclosed separately)
Type of Tender	Two Bid
Cost of Tender	Nil
Earnest Money to be deposit	Rs. 81,000 /- (Eighty One Thousand)
Last date & time of receipt of tender	17.09.2024 at 1600 Hrs.
Date & time of opening of tender (Part – I)	17.09.2024 at 1630 Hrs.
Tenure of contract	For each ship, within 45 days of PO or intimation of site clearance by Project Manager.
Pre-Bid Meeting	11.09.2024, at 10.30 AM



Registered Office: Administrative Building, HCSL Premises, Satyen Bose Road,
P.O. Danesh Shaikh Lane, Nazirgunge, Howrah, West Bengal - 711 109.
☎ +91 (33)-2688 8282 ✉ contact@hooghlycsl.com 🌐 www.hooghlycsl.com

Shipyard: Nazirgunge Unit, Satyen Bose Road, P.O. Danesh SK Lane,
P.S. Sankrail, Howrah, West Bengal - 711109
☎ +91 (33)-2955 8283

CIN : U35900WB2017GOI223197, GSTIN : 19AAECH3640L1ZD

Officer - in – Charge (tender)	For Commercial:
	Name : Vijay Singh Designation : Manager (SC&C) Email : vijay.singh@hooghlycsl.com Phone No: : +91 86870 69271
	For Technical:
	Name : Siva Prasad Designation : Manager (Electrical) Email : sivaprasad.sp@hooghlycsl.com Phone No: : +91 9487017033

Tender to be submitted by E-mail only. No hard copy quotation of the bid will be accepted.
Tender reference should be clearly indicated on the subject of the Mail.

Tenders should be submitted in two separate files as PART-I "TECHNO-COMMERCIAL" & PART-II "PRICE" (Password Protected) indicating the *tender number, due date of the tender and subject as in-line with the scope of supplies* in the Mail addressed to:
vijay.singh@hooghlycsl.com / sivaprasad.sp@hooghlycsl.com

PRE-BID MEETING

- Pre-bid meeting shall be conducted at HCSL conference room on 11.09.2024, at 10.30 AM with prospective bidders to clarify any concerns bidders may have with the tender documents, scope of work and other technical details of the requirement.
- Firms can attend the pre-bid meeting, bidders desirous of attending the pre-bid meeting are to forward the details of attending persons (with Aadhaar card details) latest by 03.08.2024 at 1700 Hrs. to Manager (SC&C) at e-mail address vijay.singh@hooghlycsl.com

The tender documents can be downloaded from HCSL/ CSL website <http://hooghlycsl.com/www.cochinshipyard.com>. The tender documents are available on above mentioned link. All corrigenda, addenda, amendments and clarifications to this tender will be hosted in the website www.cochinshipyard.com or <http://www.eprocure.gov.in> and not in the newspaper. Bidders shall keep themselves updated with all such developments till the last date and time of submission of tender.

Tender administration: Tender procedure/administration/evaluation including correspondences and awarding of contract will be done by M/s. Hooghly Cochin Shipyard Limited, Howrah, West Bengal.



For Hooghly Cochin Shipyard Limited

Table of contents

Sl. No.	Description	Annexure
1	Important Instruction to Bidders	Annexure-1
2	Technical Specification / Scope of Work	Annexure-2
3	Terms & conditions of enquiry	Annexure-3
4	General terms & conditions	Annexure-4
5	Special Terms & Conditions	Annexure-5
6	Techno-commercial check list	Annexure-6
7	Price bid format	Annexure-7
8	Vendor details	Annexure-8
9	NEFT mandate form	Annexure-9
10	List of deviation	Annexure-10
11	Form of Bank Guarantee towards EMD	Annexure-11
12	Format of bank guarantee towards SD	Annexure-12
13	Power of Attorney	Annexure-13
14	Form of self-declaration	Annexure-14
15	Form of legal cases	Annexure-15
16	Indemnity Bond	Annexure-16
17	Indicative Sample Spool Drawings	Annexure - 17



For Hooghly Cochin Shipyard Limited

IMPORTANT INSTRUCTION TO BIDDERS

Minimum Qualification Criteria for Participating in The Tender Will Be as Follows:

- 1.1. The Bidder shall be a single firm having experience in various onboard fabrication, installation & commissioning of piping system in Shipyard/Marine application.
- 1.2. Experience as contractor in the successful completion or under execution of similar scope of work in preceding 3 years. (Satisfactory completion certificate and Work-order /Purchase Order from the Client for work done should be submitted along with bid). Vendor should have completed and submit the details of work experience in preceding 03 FY years (2021-22, 2022-23, 2023-24) of similar nature of works as:

01 (one) work order of value at least Rs. 24 lakhs in past 3 FY's

OR

02 (Two) work orders of value at least Rs. 15 lakhs each in past 3 FY's

OR

03 (Three) work orders of value at least Rs. 12 lakhs each in past 3 FY's

Similar nature means "The experience of successfully completed or under execution of similar works for onboard piping fabrication, installation & commissioning of piping system in Shipyard/Marine application.

- 1.3. The Bidder should furnish the required work-specific information and satisfactory documentary evidence such as copy of work order / agreement, certificate from the employer for satisfactory completion of work along with the GST Invoice shall be submitted to HCSL in support of its claim of experience.
- 1.4. The work experience shall comprise of work having comparable nature to that of fabrication, installation & commissioning of piping system. If the experience claimed by the bidder is of no relevance with respect to fabrication, installation & commissioning of piping system, then such experience will not be considered for pre-qualification. Decision taken by HCSL in this regard will be final.

Common Requirements from the Bidders:

Following documents are required to be submitted by the bidders along with the Techno-commercial Bid (Part – I) submission:

- 1.5. The Bidder should enclose copy of statutory documents **PAN, GST registration certificate, Income tax returns for last three FY (2020-21, 2021-22, 2022-23) or of AY (2021-2022,2022-2023,2023-2024).**
- 1.6. Audited Balance sheets showing turnover, Profit & Loss account of the firm for the preceding 03 years, FY (2020-21, 2021-22, 2022-23) should be submitted along with the application for



prequalification. **Net worth of the bidder must be positive as per the latest balance sheet. (MSE/NSIC may get exemptions as per prevailing Govt. norms).**

- 1.7. The average annual turnover of the bidder should be at least **Rs. 15 lakhs** during the last three preceding FY years (2020-21, 2021-22, 2022-23).
- 1.8. Bidder shall not be under a declaration of ineligibility issued by Govt. of India/ State govt./ Public Sector Undertakings etc. The bidder shall not have been debarred / black listed by CSL/HCSL or by any of the Public Sector Undertaking or Government department etc.

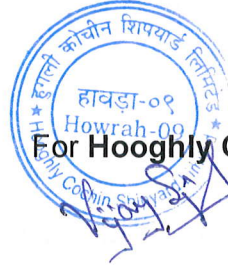

For Hooghly Cochin Shipyard Limited

TECHNICAL SPECIFICATION / SCOPE OF WORK

Fabrication, Testing, Installation & Commissioning of Piping Systems for 50pax Hybrid Catamaran Vessels (06 Nos.) being constructed at Hooghly Cochin Shipyard Ltd, Nazirgunge unit, Howrah

1. DESCRIPTION OF WORK

- 1.1 This tender enquiry pertains to the awarding of contract for turnkey fabrication, testing, installation & commissioning of piping system onboard 06 Nos. 50 pax hybrid catamaran vessels.
- 1.2 The work includes all Fabrication, Installation & Commissioning of piping system of the vessel(s) in accordance with the indicative specifications and drawings enclosed, delivery schedule, HCSL - General Terms and Conditions in all respects.
- 1.3 The work is to be carried out at Hooghly Cochin Shipyard Ltd facility at Nazirgunge, Howrah.
- 1.4 Bidder are requested to obtain clarifications, if any, and carefully study the documents and the scope of work of Contractor and HCSL, before submitting your offer.
- 1.5 The contractors are advised to familiarize themselves with the site conditions before quoting.

2. ABOUT THE VESSELS

2.1 The main particulars of the vessel are as below:

Length Overall (Hull)	:	24.8 m approx.
Breadth (mld.)	:	6.40 m approx.
Mean Draught (mld.)	:	0.9 m approx.
Propulsion	:	Conventional FPP with twin screw
Hull & main deck	:	Marine grade Aluminium
Super structure	:	FRP

The propulsion system shall be electric motors driven, supported by batteries, capable of being charged by electric supply from grid ashore. Diesel generators shall be provided on board for hybrid operation and diesel mode operation.



3. MODEL OF CONTRACTING

- 3.1. Hooghly Cochin Shipyard Ltd (HCSL) proposes to offload fabrication, testing, installation & commissioning of piping system onboard 06 Nos. for 50 pax Hybrid Catamaran Vessels.
- 3.2. All major pipes and flanges for the piping work will be provided by HCSL, along with relevant WPS/PQR and piping quality standards. **However, the items mentioned in Enclosure-3 shall be supplied by the contractor only.**
- 3.3. The work shall be carried out based on the contract specification, Piping drawing, HCSL mentioned standards and Design drawings, up to the entire satisfaction of HCSL / Owner / Class Surveyor, and up to the completion of satisfactory sea trials of the vessel.

4. SCOPE OF WORK

- 4.1 The scope of work under this tender involves:
 - 4.1.1 Complete fabrication, testing, installation & commissioning of piping system for 50 pax hybrid catamaran vessels, as per specifications and drawing (Annexure 1, Enclosure 1, 2 & 3 and Annexure 16).
 - 4.1.2 Fabrication, testing, installation and commissioning of piping systems (including support installation and flushing) per vessel as listed in Enclosure 1, Enclosure 2 and Enclosure 3. Production drawings will be provided on commencement of work.
 - 4.1.3 Fabrication scope includes Cutting, Bending, Edge preparation of the pipe spools, Fit up survey, Full Welding, Dry survey, galvanizing (for CS items) and shop floor testing.
 - 4.1.4 Installation scope includes pipe & support installation onboard and presenting dry survey.
 - 4.1.5 Commissioning scope involves testing of pipe lines, commissioning assistance till completion of the vessel. Flushing of the fuel & hydraulic pipe lines. Flushing machine to be arranged by contractor.
 - 4.1.6 Galvanization including pickling of spools: Taking from yard, pickling & galvanization of spools and return of material to yard is in contractor scope. Including insurance
 - 4.1.6 Testing scope includes blanking of pipes and pressuring with required medium and offering surveys to the HCSL QC, Owner and Class.
 - 4.1.7 Pipe will be fabricated as per specification and the drawing provided by HCSL. The reference sample drawing is enclosed at Annexure 16.
 - 4.1.8 Collection of material, material movement & accounting of the items.
 - 4.1.9 Fabrication, installation and testing of piping systems as per the details provided in list of pipe works. Fabrication & Installation drawing will be provided post award of work order.
 - 4.1.10 Survey presentation to Yard I&QC, Client and Class authorities as per yard practices and standards. Documents for the same may be accessed at HCSL. Copies of the same will be provided at the time of awarding contract.



- 4.1.11 Rectification of defects as per the comments from Yard I&QC, Client & Class authorities.
- 4.1.12 All tools and tackles, Welding machines, Flushing machine, Pressure testing pumps, pressure gauges for pressure testing, cutting tools, all consumables, production aids required for the work are under the scope of the subcontractor.
- 4.1.13 Arranging supporting blocks, jigs fixtures etc. for fabrication shall be to subcontractor scope.
- 4.1.14 Mobilization of entire labor / Workmanship (Skilled/ Semiskilled / Unskilled) required for the turnkey piping works,
- 4.1.15 The job includes drilling of holes with reference to all piping works and pipe clamps fixing,
- 4.1.16 Provision of required PPE and safety appliances to workmen,
- 4.1.17 Fabrication, fitment and testing of all piping systems as per the General Arrangement plan and piping drawings as per the below systems,
- a) Sea Water system,
 - b) Fresh Water system,
 - c) Bilge system
 - d) Ventilation system
 - e) Scupper & Drain system
 - f) Air Vent & Sounding system
 - g) Fire Water system
 - h) Eco Sounder,
 - i) Exhaust system,
 - j) Fuel oil system
 - k)Hydraulic System for Steering gear
- 4.1.18 Equipment end connection under the scope of the contractor.
- 4.1.19 Testing of piping systems as per Class requirement.
- 4.1.20 Supply & fixing of all "U" clamp for pipe support with necessary nut, washers, rubber sheet are in contractor scope as per required sizes
- 4.1.21 Welding electrodes / Welding coils, Argon gas, Helium gas, grinding wheel, gaskets all required consumables and machines & tools are under the scope of the contractor.
- 4.1.22 The entire Over-board pipe fit-up and welding on hull will be done by the respective Hull contractor engaged by the yard.
- 4.1.22 Welding of all other bulkhead/deck penetration piece to Hull will be under yard hull contractor scope.
- 4.1.23 For pipe installation all gaskets under contractor scope.



4.1.24 Removal and refit of pipes if required.

4.1.25 Hot dipped galvanization of CS

pipes is in contractor scope.

4.1.26 The last spool shall be kept loose to adjust at site to prevent mismatch and onsite fouling issues. Drawings to be matched with onboard measurements.

4.1.27 The materials as mentioned in Enclosure-3 are to be supplied and installed by the Piping contractor and the material data sheet shall be submitted to HCSL for approval before delivering.

4.1.28 Welding machines, grinding machines, cutting machines and other equipment and tools required for the successful commissioning of piping system shall be positioned by the piping contractor only. (Yard will provide only Welding coil (Aluminium consumable for Mig machine) all other items / equipment's as required to be arranged by Piping contractor).

4.1.29 ICS (International Classification society) approved Welding electrodes will be in the piping work contractor scope.

4.2. SCOPE OF HCSL

4.2.1. Supply of drawings & materials, equipment in the list of piping's (Enclosure 1&2) for Piping works for the mentioned scope of work. Remaining items as per list (Enclosure 3) in contractor scope

4.2.2. Welding coil (Aluminium consumable for Mig machine)

4.2.3. Quality Assurance Plan (QAP) and applicable Welding Procedure Specification (WPS) will be provided.

4.2.4. Providing Electricity, Water, compressed air (at available pressure).

4.2.5. Services of HCSL cranes and forklifts, subject to availability.

4.2.6. Required space for storage of materials inside the Yard (if required)

4.2.7. Staging / scaffolding

4.2.8. Welding of all other bulkhead/deck penetration piece to Hull will be under yard hull contractor scope.

4.3. COMMON REQUIREMENTS

4.3.1. The work shall be undertaken by only qualified welders of the contractor. Towards this, HCSL will provide the WPS and PQR. Welders will have to be qualified by Class IRS at Contractor's cost. The welder qualification will be carried out at HCSL and the contractor would have to pay for the testing and certification charges.

4.3.2. Work will be undertaken and inspected as per the quality standards provided by HCSL, and approved by Class and Owner of the vessels. The same may be seen prior bidding, if required. Copy of the standards will be provided while awarding contract.



4.3.4 The Bidder shall have sufficient TIG welding machine with pressure regulators for Argon gas, Helium Gas with flow meter.

4.3.5. The Bidder shall have sufficient mechanical cutting tools for cutting Aluminium / stainless steel pipes. List of portable tools used for piping works to be submitted after placement of work order.

4.4. INSPECTION / TESTING/ QA AND QC

4.4.1. Contractor to maintain the required dimensional accuracy and surface finish as per quality standards provided by HCSL

4.4.2. All test and Inspections shall be carried out as per approved QAP.

4.4.3. All works shall be as per strict compliance to weight control and approved HCSL drawings.

4.4.4. All correspondence with the Shipyard to be in English language. All documents and plans to be in English language and in metric units.

4.5. ENCLOSURE DETAILS

The materials as per Enclosure 1 & 2 will be supplied by HCSL. The materials as mentioned in Enclosure-3 are to be supplied by the Piping contractor (and the material data sheet shall be submitted to HCSL for approval before delivering). Fabrication & installation for complete works will be inclusive of material at enclosure 1, 2 & 3.



DETAILS OF PIPES (HCSL SUPPLY)

S.NO	ITEM	SIZE & SCH	MATERIAL	Total QTY for	REMARK
				01 vessel (meter)	
Aluminium Pipes					
1	Pipe	200NB SCH 80	Aluminium SMLS ST ASTM B221 6082-T6	6	IRS Certified CLASS III Pipe
2	Pipe	150NB SCH 40	Aluminium SMLS ST ASTM B221 6082-T6	8	
3	Pipe	150NB SCH 80	Aluminium SMLS ST ASTM B221 6082-T6	2	
4	Pipe	125NB SCH 40	Aluminium SMLS ST ASTM B221 6082-T6	39	
5	Pipe	125NB SCH 120	Aluminium SMLS ST ASTM B221 6082-T6	2	
6	Pipe	100NB SCH 80	Aluminium SMLS ST ASTM B221 6082-T6	6	
7	Pipe	65NB SCH 40	Aluminium SMLS ST ASTM B221 6082-T6	2	
8	Pipe	65NB SCH 80	Aluminium SMLS ST ASTM B221 6082-T6	2	
9	Pipe	50NB SCH 40	Aluminium SMLS ST ASTM B221 6082-T6	5	
10	Pipe	40NB SCH 80	Aluminium SMLS ST ASTM B221 6082-T6	12	IRS Certified CLASS III Pipe
11	Pipe	40NB SCH 40	Aluminium SMLS ST ASTM B221 6082-T6	6	
12	Pipe	32NB SCH 80	Aluminium SMLS ST ASTM B221 6082-T6	2	
13	Pipe	25NB SCH 80	Aluminium SMLS ST ASTM B221 6082-T6	2	
14	Pipe	15NB SCH 80	Aluminium SMLS ST ASTM B221 6082-T6	2	
Total (Al Pipes)				96	
Carbon Steel Pipes					
15	Pipe	125NB SCH 120	SMLS Carbon Steel ASTM A53 Gr.B	2	
16	Pipe	100NB SCH 40	SMLS Carbon Steel ASTM A53 Gr.B	6	
17	Pipe	65NB SCH 40	SMLS Carbon Steel ASTM A53 Gr.B	6	
18	Pipe	65NB SCH 80	SMLS Carbon Steel ASTM A53 Gr.B	5	
19	Pipe	50NB SCH 40	SMLS Carbon Steel ASTM A53 Gr.B	90	

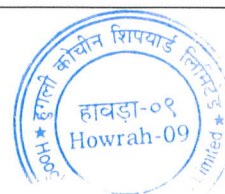

20	Pipe	50NB SCH 80	SMLS Carbon Steel ASTM A53 Gr.B	3	
21	Pipe	40NB SCH 40	SMLS Carbon Steel ASTM A53 Gr.B	47	
22	Pipe	40NB SCH 80	SMLS Carbon Steel ASTM A53 Gr.B	3	
23	Pipe	32NB SCH 40	SMLS Carbon Steel ASTM A53 Gr.B	17	
24	Pipe	32NB SCH 160	SMLS Carbon Steel ASTM A53 Gr.B	2	
25	Pipe	25NB SCH 40	SMLS Carbon Steel ASTM A53 Gr.B	3	
26	Pipe	25NB SCH 80	SMLS Carbon Steel ASTM A53 Gr.B	2	
27	Pipe	15NB SCH 40	SMLS Carbon Steel ASTM A53 Gr.B	6	
Total (CS pipes)				192	
Stainless Steel Pipes					
28	Pipe	32NB SCH 160	AISI 316L Solid Drawn SS SMLS ST	2	
29	Tube	22OD THK 2mm	AISI 316L Solid Drawn SS SMLS ST	10	
30	Pipe	20OD SCH 40	AISI 316L Solid Drawn SS SMLS ST	23	IRS Certified CLASS I Pipe
31	Tube	16OD THK 2mm	AISI 316L Solid Drawn SS SMLS ST	36	IRS Certified CLASS I Pipe
32	Tube	15OD THK 2mm	AISI 316L Solid Drawn SS SMLS ST	16	IRS Certified CLASS III Pipe
Total (SS Pipes)				87	

MISCELLANEOUS ITEMS FOR THE VESSEL (TO BE SUPPLIED BY YARD)

S.NO	DESCRIPTION	UOM	QTY PER VESSEL
1	Level Gauge For FO Tank	Nos.	1
2	Temperature Indicator With Female Boss	Nos.	10
3	Pressure Indicator With Female Boss	Nos.	4
4	Gas Sensor For Battery Vent	Nos.	2
5	3-Way Damper For Vent System	Nos.	2

The scope shall include fit up, fabrication, outfitting, testing and commissioning of piping systems including all loose fitting if any such as hoses, gauges bellow, etc.



PIPE FITTINGS (HCSL SUPPLY)

Sr. No	ITEM	SIZE & SCH	MATERIAL	QTY for 01 vessel (in Nos.)	REMARK
Aluminium Pipe Fittings					
1	Slip On Flanges	125 NB, PN10	DIN 2501 Al Welded CIR Flg With FF	27	
2	Slip On Flanges	100 NB, PN10	DIN 2501 Al Welded CIR Flg With FF	5	IRS Certified CLASS III Flange
3	Slip On Flanges	100 NB, PN10	DIN 2501 Al Welded CIR Flg With FF	15	
4	Slip On Flanges	65 NB, PN10	DIN 2501 Al Welded CIR Flg With FF	3	
5	Slip On Flanges	50 NB, PN10	DIN 2501 Al Welded CIR Flg With FF	27.5	IRS Certified CLASS III Flange
6	Slip On Flanges	50 NB, PN10	DIN 2501 Al Welded CIR Flg With FF	8	
7	Slip On Flanges	15 NB, PN10	DIN 2501 Al Welded CIR Flg With FF	11	
8	Concentric Reducer	200 X 100	Al Butt Sch 80	4.5	IRS Certified CLASS III Flange
9	Concentric Reducer	100 X 40	Al Butt Sch 80	18	IRS Certified CLASS III Flange
10	Elbow	150NB SCH 40	Al Butt Weld SR Sch40 90deg	8	
11	Elbow	125NB SCH 40	Al Butt Weld SR Sch40 90deg	30	
12	Elbow	100NB SCH 40	Al Butt Weld LR Sch40 90deg	19	
13	Elbow	50NB SCH 40	Al Butt Weld LR Sch40 90deg	9	
14	Elbow	50NB SCH 40	Al Butt Weld SR Sch40 90deg	9	
15	Elbow	40NB SCH 40	Al Butt Weld LR Sch40 90deg	20	
16	Blind Plate 150NB	Ø190 THK 12mm	DIN 2501 AL CIR Blind Plate	8	
17	Blind Plate 125NB	Ø160 THK 12mm	DIN 2501 AL CIR Blind Plate	17	
Total (Al Pipe fittings)				239	
Carbon Steel Pipe Fittings					
18	Slip On Flanges	125 NB, PN10	DIN 2501 CS Welded CIR FLG With FF	8	
19	Slip On Flanges	65 NB, PN10	DIN 2501 CS Welded CIR FLG With FF	8	
20	Slip On Flanges	50 NB, PN10	DIN 2501 CS Welded CIR FLG With FF	135	

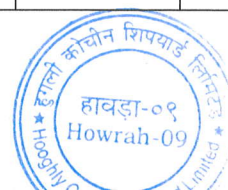

21	Slip On Flanges	40 NB, PN10	DIN 2501 CS Welded CIR FLG With FF	63	
22	Slip On Flanges	32 NB, PN10	DIN 2501 CS Welded CIR FLG With FF	12	
23	Slip On Flanges	25 NB, PN10	DIN 2501 CS Welded CIR FLG With FF	34	
24	Slip On Flanges	15 NB, PN10	DIN 2501 CS Welded CIR FLG With FF	10	
25	Marpol Flange	Ø210 THK 16mm	Carbon Steel PCD 170 4 Holes	3	
26	Marpol Blind FLANGE	Ø210 THK 16mm	Carbon Steel PCD 170 4 Holes	8	
27	Blind Plate 100NB	Ø135 THK 10mm	DIN 2501 CS CIR Blind Plate	8	
28	Blind Plate 65NB	Ø90 THK 10mm	DIN 2501 CS CIR Blind Plate	8	
29	Blind Plate 32NB	Ø75 THK 10mm	DIN 2501 CS CIR Blind Plate	10	
30	Concentric Reducer	65 X 32	CS Butt SCH 40 ASTM A234 WPB	5	
31	Concentric Reducer	50 X 32	CS Butt Sch 40 ASTM A234 WPB	10	
32	Concentric Reducer	40 X 25	CS Butt Sch 40 ASTM A234 WPB	10	
33	Elbow	100NB SCH 40	CS Butt Weld LR Sch40 90deg	10	
34	Elbow	65NB SCH 40	CS Butt Weld SR Sch40 90deg	11	
35	Elbow	50NB SCH 40	CS Butt Weld LR Sch40 90deg	61	
36	Elbow	50NB SCH 40	CS Butt Weld SR Sch40 90deg	83	
37	Elbow	40NB SCH 40	Cs Butt Weld LR Sch40 90deg	66	
38	Elbow	40NB SCH 40	CS Butt Weld SR Sch40 90deg	36	
39	Elbow	32NB SCH 40	CS Butt Weld SR Sch40 90deg	58	
40	Elbow	25NB SCH 40	CS Butt Weld SR Sch40 90deg	19	
41	Female Connector Long Boss	3/4"	CS Butt WELD SCH40	22	
42	Female Connector Long Boss	1/2"	CS Butt Weld SCH40	22	
43	Nuts And Bolts With 2 Washer	M16	MS, Electroplated	341	LENGTH 50mm
44	Nuts And Bolts With 2 Washer	M16	MS, Electroplated	465	LENGTH 60mm



45	Nuts And Bolts With 2 Washer	M16	MS, Electroplated	33	LENGTH 70mm
46	Nuts And Bolts With 2 Washer	M16	MS, Electroplated	231	LENGTH 90mm
47	Nuts And Bolts With 2 Washer	M16	MS, Electroplated	33	LENGTH 100mm
48	Nuts And Bolts With 2 Washer	M16	MS, Electroplated	33	LENGTH 120mm
49	Nuts And Bolts With 2 Washer	M12	MS, Electroplated	165	LENGTH 50mm
Total (CS&MS Pipe fittings)				2021	
Stainless Steel Pipes					
50	Slip On Flanges	20 NB , PN10	DIN 2501 SS Welded CIR FLG With FF	19	IRS Certified CLASS I Flange
51	Slip On Flanges	15 NB , PN10	DIN 2501 SS Welded CIR FLG With FF	12	IRS Certified CLASS III Flange
52	Straight Union	15OD	SS	9	
53	Straight Union	16 OD	SS	94	
54	Straight "T" Union	16 OD	SS	10	
55	Male Connector	22ODx3/4	SS	50	
56	Male Connector	22ODx1/2	SS	19	
Total (SS Pipe fittings)				213	



MATERIAL SUPPLY FOR PER SHIP (UNDER CONTRACTOR SCOPE OF SUPPLY)

DESCRIPTION (all in Marine Grade)	UOM	QTY PER VESSEL
Scupper Grating - SS316	Nos.	10
Pull Wire Mechanism For Fuel Quick Closing Valve	Nos.	1
5 mm Thick Air Vent Flap for 50NB Pipe (Galvanized FLAP)	Nos.	5
AL Box Clamp For 15 OD Tube	Nos.	70
AL Box Clamp For 22 OD Tube	Nos.	20
Set On Flange	Nos.	1
Special Flanges	Nos.	As Per Drawing
Brass 3/4 Male Connector With Nipple For Fresh Water System	Nos.	70
Brass 50 NB Fire Coupling Cap	Nos.	2
3/4 Flexible PVC Pipe For Motor And Converter Coolant Inlet	Mtr.	30
3/4 SS Hose Screw Clamp For Fresh Water Cooling System	Nos.	70
PVC Expansion Tank 10 Ltr For Freshwater Cooling System	Nos.	2
Gasket For All System	Gasket thickness, quantity and material type as required for individual system	
Wire Mesh For Vent System	Nos.	11
Flame Screen For Air Vent System - SS	Nos.	2
Flap For Exhaust Pipe	Nos.	1
M8 (30 mm Length) SS Bolts	Nos.	344
M8 SS Nuts	Nos.	344
Silicone Rubber Gasket (2000 mm X 1000 mm X 3 mm)	Nos.	4
Galvanized U- Clamp necessary fittings (Silicone Rubber Gasket, Nuts, bolts, washers, etc)	As Required	
Marine grade putty	As Required	
Nut and bolt as required other than quantity mentioned in Enclosure-2	As Required	
M8 Aluminum Bolt Nut with double plate washers (40mm length)	Nos.	20
16mm Aluminum stud with nut and washer (45mm length)	Nos.	24
Gas Spring with the maximum extendable length of 1100mm	Nos.	5
M22 x 160L Aluminium Bolt & Nut with Lock Nut	Nos.	5



	Indicative Specs for Gaskets
Piping System	Gasket Specs.
Ventilation System	Special Gasket For Duct Fan SG/MR Room
	PN10 DIN 2t Fiber Outer CIR GSK on CS Pipe for Gen Use
Sea Water Cooling System	PN10 DIN 2t Aramid Fiber Outer CIR GSK On CS Pipe For Gen Use
Fresh Water Cooling System	PN10 DIN 2t Aramid Fiber Outer CIR GSK On CS Pipe For Gen Use
Firewater System	100NB PN10 DIN 2t Aramid Fiber Outer CIR GSK On CS Pipe For Gen Use
Air Vent And Sounding System	PN10 DIN 3t Aramid Fiber Outer CIR GSK For Gen Use (Special)



TERMS & CONDITIONS

1. Fabrication, testing, installation & commissioning of piping system onboard 06 Nos. for 50 pax hybrid catamaran vessels being constructed at Hooghly Cochin Shipyard Limited, Nazirgunge Unit, Howrah.

2. METHOD OF AWARDING CONTRACT

2.1. Contract will be concluded with bidder qualifying technically (including eligibility criteria), agreeing to commercial conditions and emerging as L1 as per Annexure- 6 of this tender document.

2.2. Order will be placed on maximum 3 bidders, when they will match L1 bidder rate. Details given below:

2.3. Work corresponding to the 3 nos. vessels will be placed as confirmed order for L1 bidder.

2.4. Work corresponding to the 2 nos. vessel will be placed on L2 bidder (or next inline bidder) who matches the prices quoted by L1 bidder.

2.5. Work corresponding to the 1 no. vessel will be placed on L3 bidder (or next inline bidder) who matches the prices quoted by L1 bidder.

2.6. If none of the alternate bidders matches the L1 price, HCSL reserves the right to split the work / percentage of work to any number of bidders upon matching of L1 price or to cancel the tender if required.

2.7. If any contractor, to whom the work is awarded, is not performing as per HCSL work plan, HCSL officer in charge has the right to modify / cancel the scope of work or volume of work in WO/PO and allocate to another contractor/bidder as required. HCSL reserves the right to split the work / percentage of work to any number of bidders (up to H1) upon matching of L1 price.

3. PLACE OF WORK

Hooghly Cochin Shipyard Limited
131/1, Satyen Bose Rd, Nazirganj,
Guabaria, Mourigram, Howrah- 711109, India.

4. WORK PLAN / WORK COMPLETION SCHEDULE

4.1. For each ship, within 45 days of PO or intimation of site clearance by Project Manager.

4.2. If required, work on each vessel is to progress simultaneously.

4.3. Associated Material positioning in scope of contractor, has to ensure that it should not withhold production.

4.4. HCSL shall indicate the master construction schedule of completion of the work of vessel after awarding the contract. The contractor in turn shall submit their detailed scheduled of completion of the work, in consultation with the officer in-charge. The progress

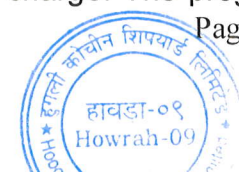

of work shall be made in tandem with the progress of completion of the vessel allowing sufficient time for other interface activities / works.

4.5. Yard has the right to change the schedules of the project in the interests of the company and the firm should be capable of adjusting the resources according to the instructions from the yard contact person.

4.6. Progress of work to be updated to officer in charge in requested format (MS Project /MS Excel/ MS Word) twice in a month/ as and when a review meeting is called for.

5. VALIDITY OF OFFER

The offer shall be valid for acceptance for a period of 90 days from the date of opening of the Part-I Techno-Commercial Bid.

6. VALIDITY OF CONTRACT

Once the contract is awarded, the price offered and mutually agreed shall remain firm till **completion of work (including optional vessels)** and no escalation in labour, transportation cost etc. shall be allowed by HCSL on whatsoever reason thereafter.

7. PAYMENT TERMS

Payment will be made for each vessel separately.

7.1. Payment will be made in 4 **stages**: (Below percentage is of total contract value of vessel)

Stage I: 15% of Total contracted value per vessel

Deliverables: Receipt and acceptance of all items (as per Enclosure 3) at HCSL stores, after inspection with necessary certificates/MTC/GC.

Stage II: 35% Total contract value per vessel

Completion of pre outfit pipe fabrication, galvanization, inspection and shop testing of all systems. Acceptance and to the satisfaction of CLASS / HCSL Officer in charge.

Stage III: 40% Total contract value per vessel

Completion of all onboard pipe support fabrication, Installation, Line survey and testing, commissioning of piping systems and successful sea trials. Completion of complete scope awarded to the contractor and subject to clearance of all surveys and inspection by class, owner/HCSL representative. Acceptance and to the satisfaction of CLASS / HCSL Officer in charge.

Stage IV: 10% of Total contracted value per vessel

Deliverables: Completion of defect liability period and Nil liability certification by HCSL officer in-charge. **OR** upon submission of Performance Bank Guarantee of equivalent amount, valid till completion of defect liability period (plus two months).

7.1.1. Payment shall be made on the basis of certification by HCSL officer in-charge. Contractor shall submit work completion certificate issued by HCSL authority.

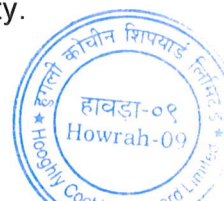

7.1.2. The payment will be made within 30 days from submission of invoice along with the work completion certificate.

7.1.3. All claims for payment for the work/ additional work (if any as per special instruction from OIC) shall be submitted by the contractor within one month of completion of work.

7.1.4. Payment will be made by RTGS/NEFT to the account of agency. The name of the bank, branch, A/C No., IFSC code & other particulars shall be furnished by the agency in the proforma of HCSL.

7.1.5. Above % payment of order value with applicable taxes will be released against original invoice subject to the full satisfaction and acceptance of work / items by Officer -In-Charge. Original tax invoice should contain GST number of both parties and submit in triplicate.

7.1.6. Statutory levies such as I.T, Contribution towards PF, ESI etc., shall be paid by contractor and documents as a proof to be submitted along with invoice.

7.1.7. The Contractor shall provide the minimum wage rate of the Central Govt. and submit the Bank account statement of the wage payment along with the bill;

7.1.8. Contractor shall indicate details such as PAN, GST. required for processing payment. HCSL reserves the right for the deduction of taxes and duties as applicable from the bill or invoice.

7.1.9. The firm must comply with statutory requirements, like ESI/EPF etc., and other labor laws/regulations in force and as amended from time to time.

7.1.10. The contractor shall provide the minimum wage rate of the Central Government & submit the bank statement of wage payment along with the bill.

7.2. Quantum of work indicated at Annexure-1 and Enclosure1, 2 & 3 is final, however additional works as per clause 8 of Annexure-3, also to be considered while quoting, actual quantum of work executed at site shall be considered for the payment purpose.

8. ADDITIONAL WORKS

Additional works up to 5% growth of work on the piping works in terms to be envisaged and is to be undertaken without any additional price impact.

8.1. Any minor modifications, resulting from the change in statutory regulations prevailing at the time of final inspection of work by classification society, to be carried out by the contractor free of cost. In case of rework/modification /additional work, the same is to be discussed and clearance to be obtained from the Officer-In-Charge before commencement of the work.

8.2. Contractor shall carry out the complete work in accordance with shipyard's approved drawings. Any minor modifications from drawing or any other work or supply of material, which is not specified hereunder, but is considered incidental and essential for the successful completion of the job shall be carried out by the contractor without any additional charge.



8.3. Contractor shall execute, during or after completion of the work, any minor job connected with the work, that is considered necessary by shipyard and/or classification society.

9. GROWTH OF WORK

HCSL shall be at liberty to place additional work to the extent of contract value at the same rate, terms and conditions of the contract within contractual period and bidder shall have to honor it. Such additional work shall be entrusted to the contractor through a separate Order to that effect or through an amendment to the Order. In any case, the contractor should not undertake any (additional) work beyond the Contractual period without prior intimation by the Officer in charge. This additional work is considered beyond the total order quantity. Unit inch dia. Rates for various sizes and material to be submitted by vendor with price bid.

10. GUARANTEE FOR THE MATERIAL TAKEN OUT FROM HCSL

The successful bidder should furnish Indemnity Bond i.e 15% of total material cost for material taken out from HCSL (for galvanization etc) in the approved format of HCSL (Annexure-15)

“All risk Insurance cover for "Material lying down at contractor premises during the work/till dispatch shall be covered under the scope of the piping Contractor only. The approximate cost of material to be insured will be intimated at the time of dispatch for outward.” However, Transit insurance to and fro shall be borne by HCSL.

11. TAXES & DUTIES

GST shall be applicable extra on the prescribed work. Bidders are requested to furnish the following details in the invoice/Bill.

- Applicable rate of GST/SAC Code
- Firms GST Reg. NO.
- Service accounting code (SAC) as prescribed by statutory authorities
- GST Registration Number of Hooghly Cochin Shipyard Limited is **19AAECH3640L1ZD**

12. MSE/ NSIC BENEFITS (If and only if the certificate issued is in the relevant field)

A. The following benefits are extended for all the firms who are registered with district industries center and come under the category of **Micro and Small Enterprises** holding a valid Entrepreneurs Memorandum (EM) Part ii certificate or Udyog Aadhaar Certificate. However, in order to avail the benefits as per public procurement policy for MSE's orders, 2012, all MSE bidders are required to declare their Udyog Aadhaar Memorandum (UAM) number in Central Public Procurement Portal (CPPP) compulsorily.

- Tender Forms Shall Be Issued Free of Cost.
- Payment of earnest money deposit (EMD) is exempted.

B. For all firms who are registered with National Small Industries Corporation (NSIC) and come under Micro and Small Enterprises holding a valid NSIC certificate, the below benefit also extended in addition to above.



Waiver of security deposit (SD) for the performance of the contract (5% of the order value by the way of bank guarantee till the supplies are completed), up to financial limit as mentioned in NSIC certificate.

C. This tender shall be based on MSE order dated 23rd march 2012, pertaining to public procurement policy.

D. MSE's quoting price band L1 + 15% (in the ascending order) may be awarded complete work, considering spirit of policy for enhancing the government procurement from MSE's.

E. Traders are exempted from the benefits from Public Procurement Policy, for MSEs Order, 2012. As mentioned in O.M. No. 5/2(2)/2021-E/P & G/Policy dated 02.07.2021, Retail and Wholesale traders can register on Udyam Registration Portal for the purpose of Priority Sector Lending (PSL) only.

13. **COST OF TENDER AND EMD (EARNEST MONEY DEPOSIT)**

- a) Cost of Tender: Nil
- b) Tenderers shall deposit an amount of **Rs. 81,000 (Rupees Eighty One Thousand)** as Earnest Money Deposit (EMD) along with the tender.
- c) The EMD can be remitted in the form of Demand Draft (DD) / Banker's Cheque / Fixed Deposit Receipt (FDR)/ Bank Guarantee drawn in favor of 'Hooghly Cochin Shipyard Ltd. payable at Kolkata and shall be valid for a period of 6 (Six) months from the due date of opening of Techno-commercial Bids from any Nationalized/ Scheduled Bank or paid online through e-gateway of -

HOOGLY COCHIN SHIPYARD LIMITED
STATE BANK OF INDIA
COCHIN SHIPYARD BRANCH
ACCOUNT NO: 37354232301
IFSC CODE: SBIN0003229

- d) EMD of bidders (unsuccessful during first stage i.e. technical evaluation etc.) shall be returned after declaration of result of first stage i.e. technical evaluation.
- e) EMD of bidders (unsuccessful after price bid opening) will be released after issuance of work order and its acceptance by the contractor to whom the work is awarded.
- f) EMD of the successful bidder will be refunded after remittance of the security deposit.
- g) EMD deposited with the Client will be forfeited,
 - (i) if a bidder withdraws or modifies his bid during the period of validity specified or
 - (ii) if the successful bidder fails within the time limit to sign the agreement document or fails to furnish the required security deposit.
 - (iii) Request for enhancement in the quoted rates or bringing in new conditions after tender opening or unnecessary delayed acceptance of the order / commencement of work / submission of Security Deposit.
- h) The relevant documents pertaining to the EMD should be enclosed with Techno-commercial Bid. **TENDERS RECEIVED WITHOUT EMD WILL NOT BE CONSIDERED FOR FURTHER EVALUATION.**



14. SECURITY DEPOSIT/WARRANTY BANK GUARANTEE

The successful tenderer shall remit 5% of the value of the contract as security deposit within 07 days of receipt of the work order. This amount after adjusting the EMD may be remitted by way of demand draft or bank guarantee (in approved proforma of HCSL) from any of the scheduled banks, valid till the satisfactory completion of the entire work i.e. completion of sea trials. The Security Deposit will be released after satisfactory completion of the contract i.e. completion of sea trials of vessel and on certification of nil liability to HCSL by Officer-in charge.

15. LIQUIDATED DAMAGES

In case of delay in supply of ordered materials or execution of work beyond the stipulated completion period, which is not attributable to HCSL, supplier is to pay Liquidated Damages (and not by way of penalty) a sum equivalent to ½% (half percent) per week or part of the week of the total basic price of the contract value subject to a maximum of 10% of the total basic price of the contract value (Total basic price is the order value excluding freight, taxes, other charges etc.). Further GST will be applicable upon LD and the same also will be deducted along with LD. However, LD applicability is without prejudice to HCSL right to terminate contract for delayed delivery or other actions as per Risk Purchase clause.

16. RISK PURCHASE

If the contractor fails to commence the work in time, as per the terms in work order or violate any other terms & conditions of work order OR If the firm's performance is found not satisfactory with regard to the progress of work, quality, and time factor, labour dispute with their workers, poor safety record, contract shall be terminated with 7 day notice and no claim whatsoever will be entertained in this regard from the firm. HCSL shall have the following rights.

- a) To terminate the contract within 7 days of notice forfeiting the Security Deposit
- b) To initiate alternative arrangements at the risk and cost of the contractor.

17. DEFECT LIABILITY PERIOD

The contractor has to guarantee the workmanship for a minimum period of 12 months from the date of successful completion of work, against defective workmanship. 10% of the Contract value shall be released to the Contractor on completion of the Defect Liability Period. Any trouble or defect originating with the workmanship of any facilities installed arises at any time up to 12 months from the date when the work is successfully completed, and the CONTRACTOR is notified thereof, the CONTRACTOR shall at his own expense and as quickly as possible make such alteration / repairs and replacements as may be necessary to comply with the above guarantees and shall reimburse any costs and expenses incurred by HCSL in connection with such trouble or defect. If the contractor fails to take action as above as HCSL shall direct, HCSL shall be free to take corrective/alternative action at the contractor's cost and risk within a reasonable time.

18. FORCE MAJEURE

18.1. Should failure in performance of the contract or part thereof arise from war insurrection, restraint imposed by government, act of legislature or other statutory authority or illegal strike, riot, legal lock-out, flood, fire, explosion, act of God or any inevitable or unforeseen event beyond

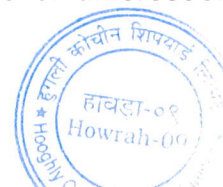

human control which may be construed as reasonable ground for an extension of time, HCSL may allow such additional time as is mutually agreed to be justified by the circumstances of the case. The occurrence/cessation of force majeure situation is to be informed with documentary evidence within 15 days from the date of occurrence/cessation.

19. TERMINATION & LIMITATION OF LIABILITY

19.1. This contract may be terminated upon the occurrence of any of the following events.

19.1.1. By agreement in writing of the parties hereto;

19.1.2. By the non-defaulting party, upon default by the other party, of any clauses of this contract, if not remedied within fifteen (15) days, or such longer time as may be agreed upon by the parties, after receipt of notice thereof in writing from the non-defaulting in party.

19.1.3. By the other party, upon either parties:

- (i) Making the assignment for the benefit of creditors, being adjudged a bankrupt or becoming insolvent; or
- (ii) Having a reasonable petition filed seeking its' dissolution or liquidation, not stayed or dismissed within sixty (60) days; or
- (iii) Ceasing to do business for any reason.

19.1.4. In cases where maximum limit of LD is reached and still the items are not delivered.

19.1.5. For fraud and corruption or other unacceptable practices.

19.1.6. Upon expiry or termination of this Contract, neither party shall be discharged from any antecedent obligations or liabilities to the other party under this Contract unless otherwise agreed in writing.

19.2. HCSL may by notice in writing to supplier terminate the order after issuing due notice i.e. '7 days' notice period. HCSL shall be entitled to compensation for the loss limited to the order value.

19.3. Liability maximum that can be claimed by the supplier shall be limited to what is due to be and has been paid by HCSL for the material delivered /work done as per the payment milestones.

20. STORAGE OF MATERIAL AND EQUIPMENT

20.1. The contractor shall arrange the storage of the materials/ equipment etc. if any, at a suitable location assigned by HCSL and shall ensure the safe and secure possession and handling of the items thus handed over to contractor. HCSL shall allot storage space within HCSL premises, if available.

20.2. As regards the equipment/ materials stored by him as above as also in use by him, HCSL will not be responsible for any damage, pilferage, accident that may take place during the course of execution of the work. It will be entirely his responsibility to keep all the equipment, materials etc., in safe custody as also hold them duly insured at his expense.



21. POWER OF ATTORNEY

The tenderer(s) shall have to sign in each page of the tender documents with official stamp as a token of his acceptance of the conditions stated therein. The person signing the tender form on behalf of another or on behalf of a firm, shall enclose to the tender, a Power of Attorney or the said deed duly executed in his favor or the partnership deed giving him such power showing that, he has the authority to bind such other persons or the firm, as the case may be, in all matters pertaining to the contracts. If the Person so signing the tender, fails to enclose the said Power of Attorney, his tender shall be liable for being summarily rejected. The Power of Attorney shall be signed by all partners in the case of partnership concern, by the proprietor in the case of a proprietary concern, and by the person who by his signature can bind the company in the case of a Limited Company.

22. ARBITRATIONS

22.1. Any disputes arising during the execution of the contract shall, in the first instance be settled by mutual discussions and negotiations. The results of such resolution of dispute shall be incorporated as an amendment to the contract, failing which the parties can resort to arbitration.

22.2. If any dispute, disagreement or question arising out of or relating to or in consequence of the contract, or to its fulfillment, or the validity of enforcement thereof, cannot be settled mutually or the settlement of which is not herein specifically provided for, then the dispute shall within thirty days from the date either party informs the other in writing that such disputes, disagreement exists, be referred to arbitration. The arbitrators shall be appointed and the arbitration proceedings shall be conducted in accordance with and subject to the Arbitration and Conciliation Act, 1996 (No. 26 of 1996) as amended from time to time and the decision of the Arbitrators shall be final and binding on the parties here to. The arbitration will be done by a Board comprising one officer nominated by each party, and a mutually agreed Umpire. Each party shall bear its own cost of preparing and presenting its case. The cost of arbitration shall be shared equally by the parties unless the award provides otherwise. The enforcement of the award shall be governed by the rules and procedures in force in the State in which it is to be executed. Performance under this Contract shall however, continue during arbitration proceedings and no payment due or payable by the parties hereto shall be withheld unless any such payment is or forms a part of the subject matter of arbitration proceedings.

22.3. In case of disputes, the same will be subjected to the jurisdiction of courts at Kolkata, West Bengal, India only. Governing law should be Indian law and place and seat of arbitration is at Kolkata, West Bengal. Language of arbitration should be English.

23. LABOUR LICENSE

The Agency has to take Labour License from the appropriate Authority for the said work under Contract Labour Regulation & Abolition Act 1970. Further the Agency has to apply for Form III to the Principal Employee with the intimation to the commencement of the work. While applying for FORM III the Agency has to submit PAN No, LIN No, registered Address and other information as desired by the Principal Employer. While Submitting the Bills The agency has to submit all the relevant documents to the HR Dept of HCSL for statutory Clearance of Bills.



24. LABOUR LAW & REGULATIONS

(Time to time amendments by Govt. to be strictly followed)

24.1. The contractor shall undertake and execute the work with contract labour only after taking license from the appropriate authority under the contract labour (regulation & abolition) act 1970.

24.2. The contractor shall observe and comply with the provisions of all labour and industrial laws and enactments and shall comply with and implement the provisions of the factories act , 1948, employees provident funds at miscellaneous provisions act, 1952, employees state insurance act, payment of gratuity act, minimum wages act, payment of bonus act, contract labour (regulation and abolition) act and all other enactments as are applicable to his and his workmen employed by him.

24.3. All contract workmen, shall necessarily be insured under the ESI scheme and be made members of the EPF scheme from the day of their engagement as contract workmen in the company. All such insured contract workmen should carry with them their ESI identity card for verification by the authorities. No contract workmen without a valid ESI identity card for verification by the authorities will be permitted to work in the company.

24.4. The Contractor shall submit the labour reports/ returns as required by the company from time to time in respect of their workmen in standard format to the concerned contracting officer so as to enable the same to reach personnel department by the 5th of every month. Delayed submission of the same shall attract penal interest /damages at the rate as levied by the respective authorities under the relevant Acts.

24.5. The Contractor shall maintain the records viz. muster roll, acquittance roll with full details, account books etc., in original. These are required for inspection by the concerned authorities under each scheme.

24.6. If the Contractor fails to pay any contributions, charges or other amounts payable under any of the aforementioned provisions of law, HCSL shall deduct or adjust amounts equivalent to such contribution, charges or amounts from amount payable to him by HCSL, including any deposit or amounts payable against bills and make payments on his account to the appropriate authority. He shall not be entitled to question or challenge such deductions, adjustments or payment made by HCSL.

24.7. Any other amount payable under any law or in respect of any person employed by the Contractor, if not paid by him, shall be deducted or adjusted by HCSL out of any amount payable to the Contractor including any Security Receipt and paid ever or withheld for payment by HCSL.

24.8. The Contractor shall be fully responsible for the conduct and discipline of the workmen employed by him in the Company premises. If such workmen commit any misconduct or criminal act inside the Company, the Contractor shall take appropriate action against such workmen. The contractor shall abide by the instructions/ guidelines issued by the Company for maintenance of discipline and good conduct among the workmen employed by him.

24.9. All person who are engaged for various works in HCSL either directly or through contractors, should produce the following documents prior to issuing their entry passes:

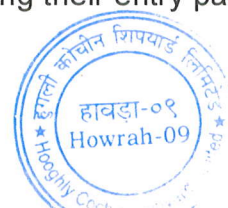

Aadhar/attested copy of Aadhar with photo and address particulars. **OR**

Police clearance certificate with photo and address particulars. (Police clearance certificate to the effect that the concerned person is staying in the area of jurisdiction of the certificate issuing police station and that the person is not involved in any criminal offences as per the records available therein.)

Application and declaration for enrolling under employee's provident fund and ESI Scheme.

24.10. Contractors are requested to familiarize themselves with the labour rules & regulations prevailing in HCSL including the labour wage pattern of contract labours.

25. SAFETY OF PERSONNEL AND FIRST AID

25.1. The contractor shall be entirely responsible for the safety of all the personnel employed by him on the work. In this regard, he may adopt all the required safety measures and strictly comply with the safety regulations in force. Detailed information and references available with HSE department of HCSL.

25.2. The Contractor may arrange to suitably insure all his workmen/ other personnel in this regard. HCSL will not be responsible for any injury or illness to the Contractor's workmen/other personnel during execution of the works due to whatsoever reasons.

25.3. In this regard, the Contractor will have to fully indemnify HCSL against any claims made by his workmen/other personnel.

25.4. The Contractor shall provide and maintain so as to be readily accessible during all working hours, a first aid box with prescribed contents at every place where he employs contract labour for executing the works.

25.5. Occupational Health, Safety & Environmental Requirements: Contractor is deemed to comply with the occupational health, safety and environmental policy of the company.

26. IMS GUIDELINES

26.1. HCSL implemented an Integrated Management System (IMS) consisting of Environmental Management system (EMS), Occupational Health and Safety Management System (OHSMS) and the Quality Management System (QMS) within the yard. As part of IMS, subcontractors shall comply with the following measures related to the Quality, Health, and Safety & Environment (QHSE) policy of HCSL.

26.1.1. Preventing occupational ill health and injuries.

26.1.2. Ensuring safe work sites.

26.1.3. Handling and disposal of Hazardous wastes safely.

26.1.4. Complying with statutory & regulatory and other requirements.

26.2. If any contractor failed to comply with or violated any clauses/requirements of occupational health, safety and environmental rules effective in the state, in their activities or at

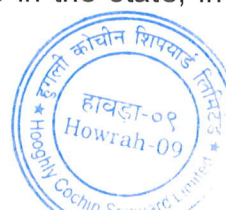

work sites and the same shall be exposed to the government or any competent authorities upon inspections, the contractor shall be solely responsible for all liabilities caused by his/her action and shall be responsible for paying the penalty and taking stipulated corrective actions insisted by the authorities within the specified time, at their own cost. Any liability to the company in this regard needs to be compensated by the contractor.

27. ELECTRICITY RULES & REGULATION

27.1. The contractor shall adhere to the various rules in respect of electrical installation as per the Indian Electricity Rules and Regulations and Electrical Inspectorate Standards in order to make sure that men and materials are safe from hazards.

28. SUB CONTRACTING AND ASSIGNMENT

28.1. Contractor shall neither assign nor transfer the Purchase Order/ Work Order nor shall any share or interest therein in any manner or degree be transferred or assigned by Contractor to a third party without prior consent in writing of HCSL.

28.2. Contractor shall not contract with any subcontractor and/or vendor without the prior written consent of HCSL. Such consent shall not relieve the Contractor from any of his responsibilities and liabilities under the Purchase Order/ Work Order. In addition, Contractor shall ensure that the terms and conditions of any such contract shall comply with and correspond to the terms and conditions of the Purchase Order/ Work Order.

29. INDEMNITY

29.1. The firm shall indemnify HCSL and keep harmless against any or all claims, liabilities, damages, losses, costs, charges, expenses, proceedings and actions of any nature whatsoever made or instituted against HCSL directly or indirectly by reason of:

- a. Any wrongful, incorrect, dishonest, criminal, fraudulent or negligent work, misfeasance, disregard of duties by personnel of the firm; and/or
- b. Any theft, robbery, fraud or wrongful act or omission by personnel of the firm.

29.2. The service provider shall indemnify HCSL or its officers against any claims arising out of accidents or injuries to workmen or other persons or damage to other property which may arise during the execution of the contract or from breach of any Law or Regulation prior to delivery and acceptance of the items at HCSL.

29.3. Under no circumstances HCSL will be responsible for any statutory compliance related to Labor, Central/State Government if any.

30. OVERWRITING & CORRECTIONS

Tenders shall be free from overwriting or erasures. Corrections and additions, if any, shall be duly attested and a separate list of such corrections shall be attached with the offer.



31. SECURITY CLAUSE

31.1. The CONTRACTOR shall be responsible to ensure that all persons employed by them in the execution of any work in connection with this contract are aware of the provisions of the official secrets act 1923 and to comply with the same. The CONTRACTOR shall also ensure secrecy of design, construction, equipment and completion of the vessel. Any information provided to you under this contract is to be treated as strictly confidential and is not to be disclosed to any person or persons not concerned therewith.

31.2. All documents under this Contract transferred between the parties shall be treated as UNCLASSIFIED unless explicitly marked.

31.3. The CONTRACTOR shall ensure that their organization, suppliers/ installation agency/test and trials teams etc. shall not communicate for use in advertising, publicity, sales release or in any other medium, system details, photographs and reproduction of equipment and their fitment on board Navy/coast guard/private owner vessels except without written approval from the competent authority of HCSL.

32. DAMAGE OF MATERIALS / EQUIPMENTS

The contractor will ensure that no damage is caused to the materials, due to negligence and / or any reason whatsoever by the contractor's man. The cost of damage will be suitably recovered from vendor's bills.

33. INDIVIDUALITY OF CONTRACT

This Contract should be treated as an individual contract and should not be related with other orders with HCSL in respect of progress of work or payment.

34. Acknowledgement of the Purchase order/Work order by signing and returning a copy of same within 3 days is required once the order is placed to vendor. If acknowledgement is not received, it will be presumed as accepted.



For Hooghly Cochin Shipyard Limited

GENERAL TERMS & CONDITIONS

1. Specific resources required/employed for the job: The contractor shall deploy and submit details of resources (equipment and manpower) of adequate capacity and quantity to be specifically provided for subject works. Details to be submitted after award of order, prior start of work.
2. The contractor/bidder must have a site-in charge/ supervisor to execute work, with a minimum experience of 3 yrs. In similar works;
3. The Contractor shall provide the minimum wage rate as prescribed by the Central Govt. to their workmen/s.
4. The Contractor shall have to engage men on round the clock basis and also on Sundays and holidays, if required. Work has to be completed to the satisfaction of Hooghly Cochin Shipyard Engineers deputed for the job. The job should be completed at the time specified by the supervising Engineer for each stage of work.
5. The upper age limit of all workers and supervisors employed by the contractor and those contractors who do or supervise the job themselves shall be as per the prevailing rules of HCSL.
6. The work will be undertaken by only qualified welders of the contractor. Towards this, HCSL will provide the WPS and PQR. Welders will have to be qualified by Class by HCSL. **The subcontractor must pay for the welder qualification, testing and certification charges to HCSL on actuals. The contractor must retain the qualified welders till the completion of the project.**
7. Work will be undertaken and inspected as per the quality standards provided by HCSL, and approved by CLASS and Owner of the vessels.
8. Area and steel skids will be provided by HCSL, leveling of the skid will be undertaken by contractor to the satisfaction of HCSL QC. Required production aids shall be arranged by Contractors.
9. The contractor shall arrange to collect and clean up every day all waste, scraps, debris, etc. generated by the work men while working onboard the vessel and other locations and dispose the same suitably at his cost to the full satisfaction of HCSL. In case any failure on his part to comply with this requirement, HCSL will arrange the required cleaning entirely at the contractor's cost.
10. Assistant General Manager (P&P) or his authorized representative will be the Officer-in-charge of this Contract.
11. Material supplied by HCSL may not be in the required size and shape. These may be cut and prepared after proper nesting by the Contractor. Special care to be taken to reduce wastages. Shortage of any material (supplied by HCSL) arising out of excess wastages due to improper planning shall have to be made up by Contractor free of cost.
12. The contractor shall be responsible for any damage caused to the material supplied by HCSL. Compensation with penalty for damage or loss of the item will be recovered from the Contractor, in the event of loss or damage.



13. Any particulars/literature/information/certificates required by the Shipyard in connection with the work is to be forwarded free of cost.

14. All correspondence with the Shipyard to be in English language. All documents and plans to be in English language and in metric units.

15. Contractor to provide all personnel protective items like safety helmets, gloves, welding shields, goggles, leg guards, safety belts, boiler suit, safety shoes etc. to their employees.

16. The firm shall be solely responsible for the payment of wages, salaries and other legal dues of its personnel who are employed or deployed by it from time to time. The firm shall promptly pay all due salaries and wages to its personnel providing service. HCSL reserves the rights to ask the firm to submit satisfactory evidence of payment due, salaries etc. In any event, HCSL shall not be liable for any payments, dues, wages and salaries of the personnel deployed by the firm.

17. Necessary Insurance Coverage for the contractor's materials / equipment / vehicle including Third Party liability and for the workmen (covering Workmen's Compensation Act) engaged by the Contractor are to be taken at his cost. If any accident/injury occurs to any other persons/public due to proven negligence/non-adherence to relevant safety and other precautions on the part of Contractor/it's employees, the contractor shall remain liable to pay necessary compensation and other expense, as decided by appropriate authorities.



For Hooghly Cochin Shipyard

SPECIAL TERMS & CONDITIONS (TWO-BID SYSTEM)

1. MODE OF SUBMISSION OF TENDERS:

- Tenders should be submitted in two separate files as **PART-I "TECHNO-COMMERCIAL"** & **PART-II "PRICE"** indicating the tender number, due date of the tender in the Mail and addressed to The Assistant General Manager (Materials), Hooghly Cochin Shipyard Limited, Nazirgunge Unit, Howrah. Tender to be submitted by Email only.
- Bidders are requested to submit the bid by e-mail (**Price part password protected**) to the following email addresses clearly mention the tender reference in the subject line for easy identification:

vijay.singh@hooghlycsl.com / sivaprasad.sp@hooghlycsl.com

- While submitting the bid, bidders are requested to note that the e-mail ID starting with following words may probable **be treated as spam, not always necessary-**
info, support, admin, sales, customer support, helpdesk, mail, mail admin, billing, hello, careers.

2. TECHNO-COMMERCIAL PART SHOULD CONTAIN FOLLOWING DETAILS:

- a. Stamped and signed copy of all pages of **tender document and corrigenda (if any)** with all supporting documents (as applicable);
- b. Financial documents as mentioned in "**Common Requirements**" of Annexure-1;
- c. **Signed Copy of un-priced Price bid (Annexure-7) (Price bid without price & with percentage of taxes & duties and details like "quoted/Nil/included" need to be mentioned for each line item.)**
- d. Signed and stamped copy of Technical Specification / Scope of Work as per **Annexure 2** with supporting documents if required
- e. Signed and stamped copy of tender terms and conditions as per **Annexure 3, 4 & 5;**
- f. Checklist duly undersigned with remarks, if any applicable as per **Annexure-6;**
- g. Vendor Details as per **Annexure-8;**
- h. NEFT mandate Form as per **Annexure-9;**
- i. List of Deviation (if Any) as per **Annexure-10;**
- j. Security Deposit formats per **Annexure-11;**
- k. Power of Attorney document as per **Annexure-13;**
- l. Self-Declaration as per **Annexure-14;**
- m. Details of Legal Case(s) pending Format as per **Annexure-15.**

All documents provided along with techno-commercial part should be stamped and undersigned. HCSL reserves the right the reject the bid in case of any discrepancies on the mentioned aspect.

3. PRICE PART:

The price part should contain the following details:

- The price correspondent to each item;
- Taxes as applicable



The price bid to be offered in the given format (Annexure – 7). Deviations to the format as given would be liable to decline of the bid so submitted.

4. **Validity:** The offer should be valid for a minimum period of **3 (Three) months** of date of tender opening.
5. HCSL reserves the right to alter, modify the scope of supply, at their discretion.
6. **Un-priced bid** to be submitted along with techno-commercial part (Part – I – Techno-commercial Bid) with details like percentage of taxes & duties applicable & details like “quoted/nil/included” to be mentioned for each line item as per Annexure-6.
7. Tenders should be submitted through E-mail only. No hard copy of the tender documents will not be accepted and may subject to rejection of the bid as a whole by the HCSL authority.
8. **Price part should be submitted exactly in the Price Format as provided (Annexure 7).** Price should be quoted separately for each item shown in the format. Combining of figures against more than one item and ambiguous clauses will lead to rejection of the bid.
9. Unprotected Price Bids/ Price Bids which are not password protected will be subject to rejection/disqualification of bid and HCSL as a whole reserves the right to cancel out such bids.
10. Check lists, technical & commercial, duly filled & signed should be submitted along with Part-I "Techno-Commercial" bid. Non-receipt of this document may lead to rejection of the offer.
11. The Techno-commercial part alone will be opened initially on the due date of tender. The price part will be opened only after evaluation of the Techno commercial part. Firms will be intimated the date of opening of the price part, whose Techno-commercial bid is acceptable, in due course. *Tenderers shall not be allowed to attend the Techno commercial bid opening.*
12. After submission of quotation / price opening, no unsolicited correspondence will be entertained.
13. Bidders can contact Officer-in-charge of the work which is indicated in the Tender Notice for any clarification before submitting the offer. If clarifications/details are not obtained before the offer is submitted, no claim on this account will be admitted.
14. The bidder shall be deemed to have carefully examined the scope of work, technical specifications, general & special terms and conditions, and other necessities mentioned in the tender and have to satisfied himself as to the nature and character of the works to be carried out, the site conditions and all relevant matters & details.
15. All pages of offers including price bids, supporting documents etc. are to be signed by authorized signatory in each page and company seal should be affixed on each page. In case of non-compliance, offer is liable for rejection.
16. Bidder should make sure that they comply with all the techno-commercial details in additional to adhere to all technical specifications during the whole process (i.e. Starting



from bid submission to carry out scope of work as per work agreements and as applicable) and provide necessary MSE/NSIC Certificates to avail exemptions, if applicable.

17. Participants/Vendors are requested to obtain clarifications, if any, and carefully study the documents and the scope of services and HCSL, before submitting your offer.
18. If any case of the above conditions is not acceptable to the tenderer, it should be specifically indicated in the tender, failing which it will be presumed that all the terms and conditions are acceptable.
19. HCSL have full right upon deviations, if any, including rejecting the partial scope/ complied offers.
20. Offers should be clear and unambiguous. Incomplete/ambiguous offers are likely to be rejected.
21. Bid Submission shall include Amendment / corrigendum / response to pre bid query duly signed and accept (if any).
22. After scrutinization of documents (Part – I) provided by the bidders, and after successful techno-commercial qualification, bidders will be contacted prior to opening of price bid. Passwords will be asked before opening of price bid. Authorized representor is required during the opening of price bid.
23. The bidders are advised to familiarize themselves with the site conditions before quoting.
24. Supplier should depute only persons who are entitled for exemption for income tax in India or any site work. In case the supplier does not depute such persons, the tax liability will be to supplier's account.
25. After submission of tender, no unsolicited correspondence will be entertained.
26. Hooghly Cochin Shipyard Limited does not bind itself to accept the lowest or any tender but reserves to itself the right to reject any or all or a part of any tender at its discretion.
27. During the evaluation of tender, officer-in-charge may seek clarifications from the bidders. Clarification if any shall be given in writing/e-mail. Officer-in-charge's decision will be final and binding on the bidder.
28. All applicable taxes, duties, transportation, delivery, etc at HCSL Nazirgunge, should be included in the rate quoted, unless specified otherwise. HCSL reserves the right for the deduction of taxes and duties as applicable from the bill or invoice.
29. Bidders to note that no advance payment will be made by HCSL against purchase order issued.



For Hooghly Cochin Shipyard Limited

Techno-Commercial Checklist for Tender for Fabrication, Testing, Installation & Commissioning of Piping Systems for 06 nos. Hybrid Aluminium Catamarans at HCSL				
Sl. No.	DESCRIPTION	COMPLIANCE		REMARKS
		YES	NO	
1	Submission of Tender in two (2) parts – Techno-commercial & Price (Password protected)			
2	Work Completion Period as per Tender			
3	EMD			
4	Validity of offer – 90 Days			
5	Payment Terms acceptance			
6	The Prices offered should remain firm till the completion of work, in case the work order is placed with you.			
7	Have you specified Taxes, duties, levies etc., if any, in the offer?			
8	Signed and stamped copy of unpriced bid (mentioning taxes and duties) and “quoted/nil/included” against each line item as per Annexure 6 to be included in the techno- commercial offer. Please confirm			
9	Compliance with Pre-qualification criterion with supporting documents			
10	Self-attested copy of PAN Card, GST, ESI, EPF and MSME/NSIC registration certificate.			
11	Disputes in connection with contract subject to jurisdiction of courts at Kolkata, India.			
12	Defect Liability Period as per relevant clause in the terms of enquiry.			
13	L.D. payable as per relevant Clause in the General terms of enquiry.			
14	Termination of contract/Risk purchase as per relevant clause in the General terms of enquiry.			
15	Contractor to provide minimum wage structure as prescribed by Central Govt.			
16	ITR, Balance Sheets, Profit & loss statement for FY 2020-21, 2021-22 &2022-23 submitted with the Bid.			
17	List of Deviations to be submitted as per Annexure 8			
18	Supplier should have minimum average annual turnover of Rs. 15 Lakhs as on 31 st March (FY 2020-21, 2021-22 and 2022-23) Supporting document to be submitted along with technical bid			
19	Confirm all other terms and conditions of enquiry are acceptable.			

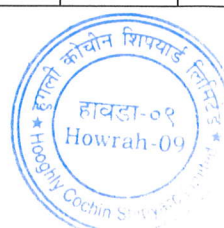

PRICE BID FORMAT**Fabrication, Testing, Installation & Commissioning of Piping System Onboard 06 Nos. 50pax Hybrid Catamaran Vessels**

Sl. No.	Work Description	UOM	Total Qty. (A) Per Vessel	Basic Amount Per vessel (INR) (B)	Amount Without GST (INR) C=A X B	GST Amount (INR) (D)	Total Amount including GST (INR) E=C + D
1	Fabrication, Testing, Installation & Commissioning of Piping System as per Annexure 2, complete Scope of Work including scope, material supply & galvanization.	LS	1				
	Total Amount without GST (INR) per vessel						
	GST Amount (INR) per vessel						
	Total Amount with GST (INR) per vessel						
	Grand Total amount including GST for 06 vessels						
	Grand Total Amount with GST (INR) in Words for 06 vessels						

Note:

- The quoted price will be valid for a period of 3 (three) months.
- Quoting for all serials is mandatory. Partially quoting for few serials shall result in rejection of the bid.
- L1 Bidder will be decided without considering Taxes.
- Rate agreed upon as per quotation shall remain firm and fixed till conclusion of contract.
- Bidders shall quote total amount in figures and in words. Corrections and additions if any must be attested / duly signed by the bidder. In the case of error in multiplication / addition in amount calculated, unit rate quoted will be considered as correct and the amount will be calculated accordingly. Conditional rebates & discounts, incomplete/ambiguous offers are likely to be rejected.
- Bidder has to submit the price bid as mentioned in the format only, otherwise bid will be rejected
- Un-priced bid to be submitted along with techno-commercial part (**Part – I – Techno-commercial Bid**) with details like "**quoted/nil/included**" to be mentioned for each line item

*Any modifications or alterations or additional notes added to the above format will straight away leads to rejection of the offer.

Signature:

Address of the contractor:

Seal:



Following information is required for applicable rates and will be used in case if any modifications or growth of work is required. This won't be used for L1 determination for this tender:

'Per Inch Dia. Rates for Fabrication, Erection, Pressure Testing & Installation of spools.'					
Size	Aluminium SMLS ST ASTM B221 6082-T6 (INR) Per Inch Dia. Rates	Size	SMLS Carbon Steel ASTM A53 Gr.B (INR) Per Inch Dia. Rates	Size	AISI 316L Solid Drawn SS SMLS ST (INR) Per Inch Dia. Rates
200NB SCH 80		125NB SCH 120		32NB SCH 160	
150NB SCH 40		100NB SCH 40		22OD THK 2mm (Tube)	
150NB SCH 80		65NB SCH 40		20OD SCH 40	
125NB SCH 40		65NB SCH 80		16OD THK 2mm (Tube)	
125NB SCH 120		50NB SCH 40		15OD THK 2mm	
100NB SCH 80		50NB SCH 80			
65NB SCH 40		40NB SCH 40			
65NB SCH 80		40NB SCH 80			
50NB SCH 40		32NB SCH 40			
40NB SCH 80		32NB SCH 160			
40NB SCH 40		25NB SCH 40			
32NB SCH 80		25NB SCH 80			
25NB SCH 80		15NB SCH 40			
15NB SCH 80		Galvanizing Cost (per KG)			

Signature:
Address of the contractor:
Seal:



COMPLIANCE STATEMENT- LIST OF DEVIATIONS		PAGE 1 OF 1
Tender Name: Fabrication, Testing, Installation & Commissioning of Piping Systems for 50pax Hybrid Catamaran Vessels (06 Nos.) at HCSL, Nazirgunge unit, Howrah.		
TENDER NO:		
DATE:		
We hereby confirm and truly declare that our Offer / Bid No.datedis in full compliance with the documents issued against the Tender No. ----- dated -----, except for the deviations listed below:		
LIST OF DEVIATIONS		
Sl. No.	Description / Tender Reference	Reasons for Deviation
Name of tenderer:		
Date:	Name & Designation	Seal &
Signature		
(Company Seal)		



Vendor details (to be submitted along with TECHNICAL BID)

1	Name of Bidder/Firm	
2	Registered office Address of Company/firm in Kolkata/Howrah: Local office address at Kolkata/Howrah (if held):	
3	Telephone No./Fax No./Mobile No	
4	E-mail address:	
5	Names of the contact person & Designation: (of person in connection with this tender) :	1) 2) 3)
6	Type of Entity-Pro praetorship/Partnership firm/company/NSIC/MSE Category etc. (Please attach registration certificate of Firm/Partnership agreement/proprietorship documents)	
7	Cost of Tender Details (DD No. Name of Bank)	
8	EMD Details (DD No. Name of Bank)	
9	PAN Card Number (Self-attested copy of PAN card has to be Submitted)	
	GST Registration No. (Self-attested copy has to be Submitted)	
10	Whether the agency has been blacklisted/debarred or given tender holiday or contract terminated before expiry of the contract period by any govt. autonomous bodies/organizations where bidder has provided services earlier due to deficiencies in service or misconduct etc.	Yes/No (Please tick as applicable) If yes, please furnish details on a separate sheet

Certified that the above information is true to the best of our belief and information.

Place:

Date:

Signature of Supplier/Authorized signature of firm/agency:

Name of Supplier or authorized signatory of firm/agency:

Designation:

NEFT mandate form

(ON THE LETTER HEAD OF THE BIDDER)

Electronic Payment Mandate Form

(Mandate for receiving payments through RTGS/NEFT Hooghly Cochin Shipyard Ltd)

- 1) Vendor Name
- 2) Vendor Address with Phone No
- 3) Vendor Code
- 4) Permanent Account No. (PAN)
- 5) Particulars of Bank Account
 - a. Name of the Bank

 - b. Name of the Branch

 - c. Branch Code
 - d. NEFT Code of the Bank
 - e. City Name
 - f. Branch Location
 - g. Branch Telephone No.
 - h. Bank IFSC Code
 - i. 9-Digit MICR Code

(Where MICR is starting with "0". Please take the correct code from your bank for proper identification of city, bank, branch)

i. Type of the Account (S.B
Current or

Cash Credit) with code
(010/011/013)

j. Account Number (as
appearing on the cheque book)

- 6) Email Address of Vendor
- 7) Date of Effect of RTGS/NEFT in your Bank

We hereby declare that the particulars given above are correct and complete. If the transaction is delayed or lost because of incomplete or incorrect information, we would not hold the company responsible.

(.....)
Signature of Employee

Bank Certificate

We certify that _____ has an Account No. _____ with us and we confirm that the details given above are correct as per our records.

Date:

Place:

(.....)
Authorized official of Bank

Note: Please enclose a cancelled un-signed cheque leaf to enable us to verify the details mentioned above.

Form of bank Guarantee towards EMD

(On stamp paper of value Rs. 200/-)

This deed of GURANTEE made on day of Two thousand Eighteen between HCSL on the one part and (Name and address of the bank) of the other part is as follows: -

In consideration of the HCSL having allowed M/s..... (Hereinafter referred to as 'the Supplier') to submit Tender No..... to them without Earnest Money according to the conditions of such Tender Notification.

We..... (here enter the name of 'the Bank') a Company incorporated under theAct and having its registered office at(hereinafter referred to as 'the bank') undertake to pay to HCSL on demand at Kolkata the sum of money payable as Earnest Money in respect of the Tender No.....made by the Supplier, in case the Supplier withdraws the tender before the date of firmness stipulated or when the tender is accepted by or on behalf of the HCSL the Supplier makes default in furnishing the Security Deposit or in entering into an agreement as required by the HCSL or otherwise commits any breach of the terms and conditions of the tender.

We,Bank Guarantee to pay the amount due and payable under this guarantee without any demur merely on demand from the HCSL. Any such demand made on the Bank shall be conclusive as regards the amount due and payable by the Bank under this guarantee. The liability of the surety shall be restricted to Rs(Rs..... only)

This guarantee shall not be avoided, released or affected by any variation in the terms of the tender, acceptance or the contract between the Contractor and the HCSL or any neglect indulgence or forbearance by the HCSL.

This guarantee shall remain in full force and effect during the period that would be taken for the finalization of the tender and till the HCSL certifies that the terms and conditions of the said tender have been fully and properly carried out by the Supplier and accordingly discharges this guarantee or for Six Months from the date of issue of this guarantee whichever is earlier. A notice of the claim under this guarantee may be served on the Bank within Six Months after the said period in which

case the same shall be enforceable against the Bank notwithstanding the fact that the same is enforced after the expiry of the said period.

The decision of the CEO, HCSL as to whether the occasion or the ground has arisen for the demand of the surety form Bank shall be final. The HCSL shall be at liberty to act as though the Bank were the principal debtor.

We, the said Bank lastly undertake not to revoke this guarantee during its currency except with the previous consent of the HCSL in writing and agree that any change in the constitution of the said contractor or the said Bank shall not discharge our liability hereunder.

In witness whereof we have hereunto set our hand and seal this. day
.....of.....Two thousand and
.....

Place:

Date:

**Bank guarantee in lieu of security deposit/
Warranty guarantee**

To
HOOGHLY COCHIN SHIPYARD LTD
(Govt. of India Enterprise)
Satyen Bose Road,
Danesh SK Lane (PO),
Nazirgunge, Howrah,
West Bengal - 711109.

WHEREAS(Name & Address of Supplier) (hereinafter called " **the Supplier**")
has undertaken, in pursuance of
Contract.....No.....Dated:.....to execute (Name
of Contract and brief description of works) (hereinafter called "**the Contract**").

AND WHEREAS it has been stipulated by **HOOGHLY COCHIN SHIPYARD LTD** (The Buyer –
hereinafter called "**HCSL**") in the said contract that the Supplier shall furnish **HCSL** with a Bank
Guarantee for the sum specified therein as security for compliance with the Supplier's
obligations in accordance with the Contract.

AND WHEREAS we have agreed to give the Supplier such a Bank Guarantee.

NOWTHEREFORE we.....(Name of the Bank) having its Head Office
at.....(Address of Head Office) and acting through its branch office
at.....(Address of the executing branch)(hereinafter called "the Bank") hereby
affirm that we are the Guarantor and responsible to **HCSL**, on behalf of the Supplier upto a total
of.....(amount of Guarantee) in words).

We, the bank, hereby irrevocably undertake to pay you any amount not exceeding in total the
Guarantee Amount upon receipt by us of your demand in writing accompanied by the following
documents:

1. Your signed statement certifying that the Supplier is in breach of his obligation(s) under
the Contract and the respect in which the Supplier is in breach.
2. Your signed statement certifying that the Supplier has been given a prior written notice by
email from you to make good the aforesaid breach and that the Supplier still failed to fulfill
the Contract within 30 days of such notice. A copy of such notice given by email to the
Supplier shall be attached to the demand for payment.

Any demand for payment should contain your authorized signatures which must be authorized by
your bankers or by a notary public.

We, the Bank, further agree that no change or addition to or other modification of the terms of
the Contract or of the Works to be performed there under or of any of the Contract documents
which may be made between **HCSL** and the Supplier shall in any way release us from any
liability under this guarantee, and we hereby waive notice of any such change, addition or
modification. We, the Bank, further agree that any change in the constitution of the said
contractor or the said bank shall not discharge our liability hereunder.

Notwithstanding anything contained herein:

1. Our liability under this Bank Guarantee shall not exceed(only).

2. This Bank Guarantee shall be valid upto (date) and

3. We are liable to pay the guaranteed amount or any part thereof under this bank guarantee only and only if **HCSL** serve upon us a written claim or demand on or before.....(validity date).

Any demand for payment under this guarantee must be received by us at this office during working hours on or before the validity date. Should we receive no claim from you by the validity date, our liability to you will cease and the guarantee will definitely become null and void whether returned to us or not.

Yours truly,

Signature and seal of the guarantor:.....

Name of Bank:.....

Address:.....Date:.....

^[1]An amount shall be inserted by the Guarantor, representing the percentage of the Contract Price specified in the Contract and denominated in respective Dollars / Indian Rupees/Other Currency.

POWER OF ATTORNEY

(On Applicant's Letter head)

(Date and Reference)

To
The Assistant General Manager
Hooghly Cochin Shipyard Limited
Nazirgunge, Howrah-711109, West
Bengal.

Subject: Power of Attorney

Mr. / Mrs. / Ms..... (Name of the Person(s),
domiciled at.....(Address),
acting as..... (Designation and name of the company), and
whose signature is attested below, is hereby appointed as the Authorized Representative and
authorized on behalf of
(Name of the company) to provide information and respond to **enquiries etc.** as may be required by
the Employer for the project of
(Project title) and is hereby further authorized to sign and file relevant documents in respect of the
above.

(Attested signature of Mr. _____).

For.....

(Name & designation)

(Company Seal)

Self-Declaration to be given by the bidder in Letter head

Bid's Reference No. & Date:

Bidder's Name & Address:

Person to be contacted:

Designation:

Telephone No.:

Fax No.:

Email:

1. We do hereby declare that we have not been debarred/black listed by HCSL or by any of the Public Sector Undertaking or Government department etc.

2. If HCSL finds that, we have been blacklisted/ debarred by any of the Public Sector Undertaking or Government department, and then HCSL can reject the offer or terminate the contract at any point of time. In such case, we are aware that, EMD, security deposit, performance guarantee etc will be forfeited by HCSL. Further we are confirming herewith that, any loss that has happened to HCSL due to this will be compensated by us.

For and on behalf of the firm
(Firms Name & Address)

(Signature of Authorized Signatory)

Name:

Designation

Phone No.:

Seal:

Date:

Place:

Form of Legal Case (Sample Format)

Details of legal cases pending against the firm for the last five years

SL. NO.	ORGANISATION AGAINST WHOM THE LITIGATION IS INVOLVED	BRIEF DETAILS OF DISPUTE	AMOUNTS INVOLVED (Rs.)	PRESENT STATUS	Remarks

- If no Cases pending please mention as "NIL" and submit the above form.

SIGNATURE OF BIDDER

INDEMNITY BOND

To
Hooghly Cochin Shipyard Ltd
(Govt. Of India Enterprise)
Sateyn Bose Road, Danesh Shaikh Lane
Nazirgunge, Howrah
West Bengal-711109

Gentlemen:

In accordance with the Conditions of Contract No.
Date..... (Hereinafter called the Contract) for the supply/ work of...
..... (Name of the item), M /s
..... (Name and address of Contractor) (herein after called the Contractor) shall deposit with HOOGHLY COCHIN SHIPYARD LTD, HOWRAH, (herein after called ' HCSL') An Indemnity Bond to indemnify HCSL under the Contract for an amount of Rs (amount of Bond... (in words) , in consideration of HCS L effecting advance payment/ free issue of materials amounting to Rs(in figures ; (Rupees.....(1) words , being 15 % (fifteen percent) of contract value.

NOW THEREFORE we ...
..... (Name of the contractor) having registered office at ...
..... (Add res s of the Registered Office) and acting through its branch office at ... (Address of the executing branch if any), agree unconditionally y and irrevocably to indemnify HCS L on its first demand without whatsoever right of objection on our part in the amount not exceeding Rs (Amount of Bond) Rupees..... only (in words)

We, the Contractor, further agree that no change or addition to or other modification of the terms of the Contract or of Works to be performed there under or of any of the Contract documents which may be made between HOOGHLY COCHIN S HIPYARD LTD, HOWRAH and us shall in

any way release us from any liability under this Indemnity Bond, and we hereby waive notice of any such change, addition or modification.

The guarantee shall remain valid and in full effect from the date of the advance payment under the Contract until HOOGLY COCHIN SHIPYARD LTD, HOWRAH receives full quantity from the Contractor under the said Contract

Notwithstanding anything contained herein:

1. Our liability under this Indemnity Bond shall not exceed
Rs.....(Rupees.....
.....only)
2. This Indemnity Bond shall be valid up to (date) and
3. We are liable to pay the amount of this Bond or any part thereof under this Bond only and only under the above items if you serve upon us a written claim or demand on or before.....(date).

Signature & Company's Common seal

Name of Contractor

Address -----

Date-----

Indicative Sample Spool Dwg. Annexure - 16

POS	DESCRIPTION	QUANTITY	FAB. LGTH/ PULL DIMENSION
1	40NB SCH 40 SEAMLESS CARBON STEEL PIPE (ASTM A 53 Gr.B)	480 MM	480
2	40NB SCH 40 SEAMLESS CARBON STEEL PIPE (ASTM A 53 Gr.B)	278 MM	278
3	40NB BUTT WELD SCH40 BLK ASTM A234WPA FCS 90deg L.R ELB SMLS	1 PCS	114
4	40NB PN10 DIN CARBON STEEL WELDED CIR SLIPON FLG WITH FF	1 PCS	5

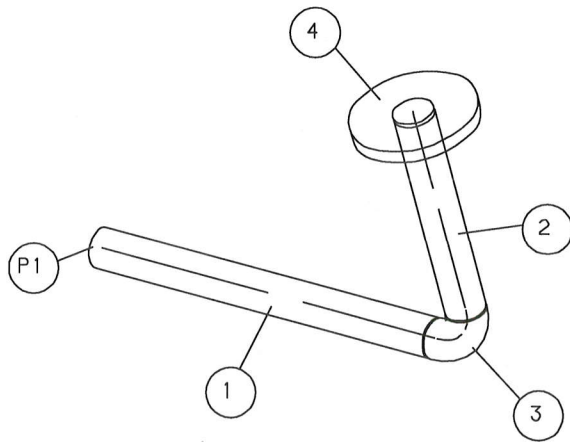
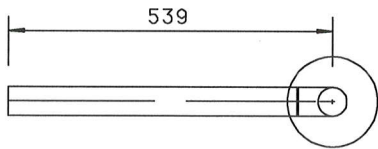
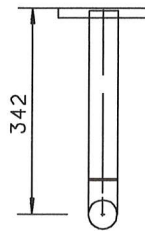
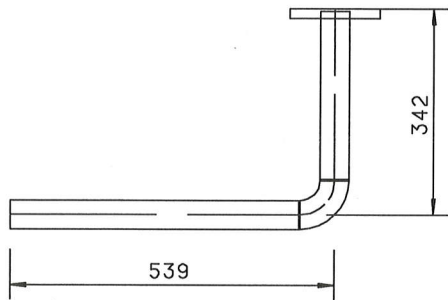

4 0.0

E 3: :

				FEED			ROTATION		BEND	
POS	TURN ANGLE OF FLG.	INCLINATION OF BRANCH	TURNING ANGLE OF BRANCH	REMARKS	BEND RADIUS	D	BENDING DATA			
WEIGHT (Kg)	INSPECTION	ACID PICKLING	INSULATION	HYDRAULIC TEST Pr. k g / cm ²	GRADE	ITEM NO	PAINT CODE			
5	BILGE SYSTEM			6.00	3					
DATE	DRAWN BY		CHECKED BY	APPROVED BY	PALLET NO.		PIPEPIECE MARK			
24-05-13	SARAN KUMAR				T4ASG000		001-T4ASG000-8031P101-2			

POS	DESCRIPTION	QUANTITY	FAB. LGTH/ PULL DIMENSION
1	40NB SCH 40 SEAMLESS CARBON STEEL PIPE (ASTM A 53 Gr.B)	135	MM 135
2	40NB SCH 40 SEAMLESS CARBON STEEL PIPE (ASTM A 53 Gr.B)	383	MM 383
3	40NB SCH 40 SEAMLESS CARBON STEEL PIPE (ASTM A 53 Gr.B)	150	MM 150
4	40NB BUTT WELD SCH40 BLK ASTM A234WPA FCS 90deg L.R ELB SMLS	1	PCS 114
5	40NB BUTT WELD SCH40 BLK ASTM A234WPA FCS 90deg L.R ELB SMLS CUT 55.0 DEGREES	1	PCS 59
6	40NB 5.01t S1 SLEEVE FOR CARBON STEEL PIPE	1	PCS 0

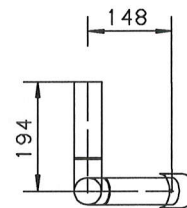
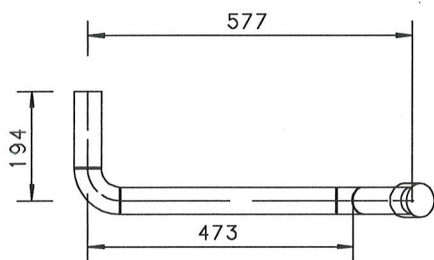

NOTE:
THIS SPOOL TO BE FABRICATED AS PER SITE CONDITION.

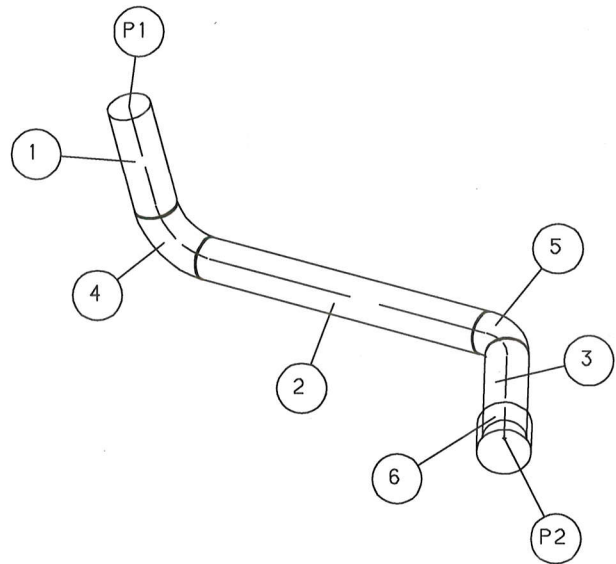
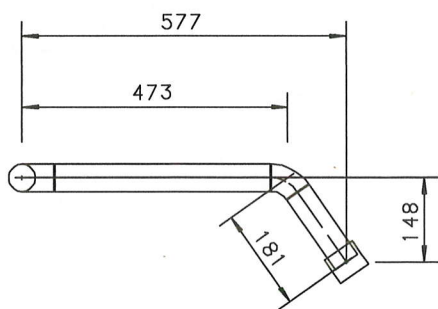

4	90	90	E 5 :
5	125	90	E 4 :

POS	TURN ANGLE OF FLG.	INCLINATION OF BRANCH	TURNING ANGLE OF BRANCH	REMARKS	BEND RADIUS	D	FEED	ROTATION	BEND
							BENDING DATA		
WEIGHT (Kg)		INSPECTION/ACID PICKLING/INSULATION		HYDRAULIC TEST Pr. kg/cm ²	GRADE	ITEM NO.	PAINT CODE		
4	BILGE SYSTEM			6.00	3				
DATE	DRAWN BY	CHECKED BY	APPROVED BY	PALLET NO.	PIPEPIECE MARK				
24-05-13	SARAN KUMAR			T4AMR000	001-T4AMR000-8031P102-1				

POS	DESCRIPTION	QUANTITY		FAB. LGTH/ PULL DIMENSION
1	40NB SCH 40 SEAMLESS CARBON STEEL PIPE (ASTM A 53 Gr.B)	166	MM	166
2	40NB SCH 40 SEAMLESS CARBON STEEL PIPE (ASTM A 53 Gr.B)	662	MM	662
3	40NB BUTT WELD SCH40 BLK ASTM A234WPA FCS 90deg L.R ELB SMLS CUT 20.0 DEGREES	1	PCS	20
4	40NB 5.01t S1 SLEEVE FOR CARBON STEEL PIPE	1	PCS	0

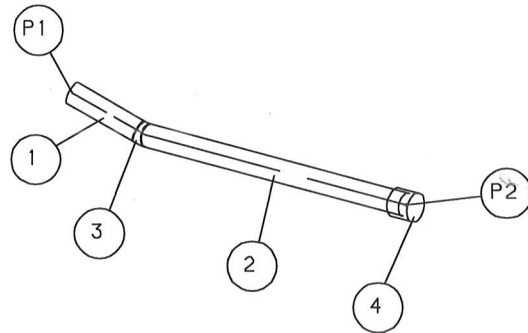
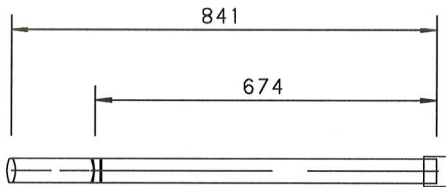
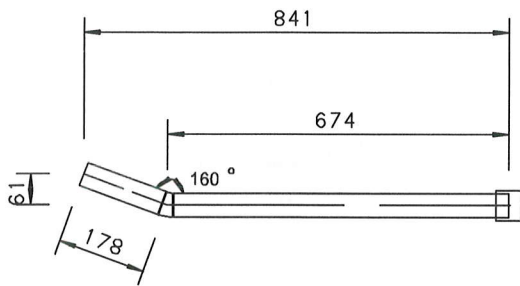

POS	TURN ANGLE OF FLG.	INCLINATION OF BRANCH	TURNING ANGLE OF BRANCH	REMARKS	BEND RADIUS	D	FEED	ROTATION	BEND
							BENDING DATA		
WEIGHT (Kg)	INSPECTION	ACID PICKLING	INSULATION	HYDRAULIC TEST Pr. kg/cm ²	GRADE	ITEM NO	PAINT CODE		
4				BILGE SYSTEM	6.00	3			
DATE	DRAWN BY		CHECKED BY	APPROVED BY	PALLET NO.		PIPEPIECE MARK		
24-05-13	SARAN KUMAR				T4AMR000		001-T4AMR000-8031P102-2		

POS	DESCRIPTION	QUANTITY	FAB. LGTH/ PULL DIMENSION
1	40NB SCH 40 SEAMLESS CARBON STEEL PIPE (ASTM A 53 Gr.B)	238	MM 238
2	40NB SCH 40 SEAMLESS CARBON STEEL PIPE (ASTM A 53 Gr.B)	27	MM 27
3	40NB SCH 40 SEAMLESS CARBON STEEL PIPE (ASTM A 53 Gr.B)	43	MM 43
4	40NB BUTT WELD SCH40 BLK ASTM A234WPA FCS 90deg L.R ELB SMLS	1	PCS 114
5	40NB BUTT WELD SCH40 BLK ASTM A234WPA FCS 90deg L.R ELB SMLS	1	PCS 114
6	40NB BUTT WELD SCH40 BLK ASTM A234WPA FCS 90deg L.R ELB SMLS	1	PCS 114
7	40NB PN10 DIN CARBON STEEL WELDED CIR SLIPON FLG WITH FF	1	PCS 5

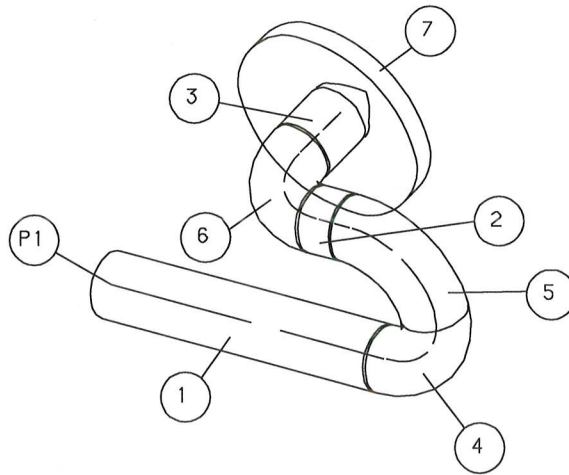
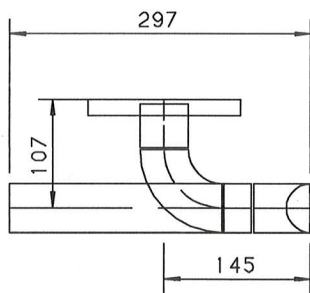
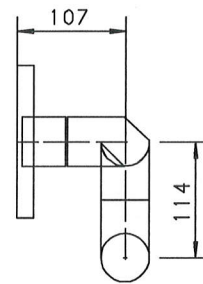
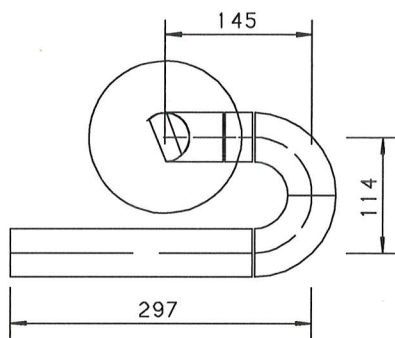

4	90	0	E 5: :
5	90	0	E 4: :
6	90	-90	E 5: :
7	0.0		E 6: :

POS	TURN ANGLE OF FLG.	INCLINATION OF BRANCH	TURNING ANGLE OF BRANCH	REMARKS	BEND RADIUS	D	FEED	ROTATION	BEND
							BENDING DATA		
WEIGHT (Kg)				INSPECTION/ACID PICKLING/INSULATION	HYDRAULIC TEST Pr. kg/cm ²	GRADE	ITEM NO	PAINT CODE	
4				BILGE SYSTEM	6.00	3			
DATE		DRAWN BY		CHECKED BY	APPROVED BY	PALLET NO.	PIPEPIECE MARK		
24-05-13		SARAN KUMAR				T4AMR000	001-T4AMR000-8031P102-3		