

TENDER No.: UCSL/CC/SB/T/175-182/241/2026 DT:08-06-2026

**TENDER FOR FITUP & WELDING OF KORT NOZZLES,
STERN TUBE, RUDDER TRUNK, STERN TUBE COVER
PLATE ON 6300TDW GENERAL CARGO VESSEL**



UDUPI COCHIN SHIPYARD LIMITED

**UDUPI COCHIN SHIPYARD LIMITED
MALPE, UDUPI 576108**





Tender For Fit up & Welding of Kort Nozzles, Stern Tube, Rudder Trunk, Stern Tube Cover Plate On
6300 DWT General Cargo Vessel
UCSL/CC/SB/T/175-182/241/2026 DT:08th Jun 2026

TENDER NOTICE

Tender No. & date	UCSL/CC/SB/T/175-182/241/2026 DT:08 th JUN 2026
Name of work	TENDER FOR FITUP & WELDING OF KORT NOZZLES, STERN TUBE, RUDDER TRUNK, STERN TUBE COVER PLATE ON 6300TDW GENERAL CARGO VESSEL
Last date & time of receipt of tender	22nd JUNE 2026 (MONDAY), 15:30HRS.
Date & time of opening of Technical Bid (Part-I)	22nd JUNE 2026 (MONDAY), 15:30HRS.

1. Password protected quotations in the prescribed form is invited from bidders for the work specified above, subject to the terms and conditions as mentioned in the annexure to the tender enquiry so as to reach the undersigned by email mentioned on or before the date and time as stipulated.

2. **The following shall be submitted along with the quote: -**

PART- I: TECHNICAL BID

- a. **Tender document duly signed on all pages** - Including Terms & conditions and scope of work placed at Annexure I
- b. **The Techno commercial Check List** at Annexure IV to be filled up completely and duly signed.
- c. Duly filled form at Annexure – II and V.
- d. **Unpriced Price bid** (Price bid without price and marked as “QUOTED”) to be submitted along with Part-I.

PART-II: PRICE BID

- a. The price bids shall be prepared based on the price bid format at Annexure III.

3. Mode of Submission of Quote:

- i. Bid shall be submitted as **Password Protected Zip File** in two parts.
Part I: Technical Bid – with all enclosures and annexures as mentioned in Para 3 above
Part II: Price Bid.
- ii. The files are to be forwarded as **Two (2) separate password protected Zip files** to contractcell@udupicsl.com
- iii. **Part I and Part II are to be protected with separate and distinctly different passwords.**





**Tender For Fit up & Welding of Kort Nozzles, Stern Tube, Rudder Trunk, Stern Tube Cover Plate On
6300 DWT General Cargo Vessel
UCSL/CC/SB/T/175-182/241/2026 DT:08th Jun 2026**

- iv. The Bids will be opened on online mode during which the bidder will be advised to share the password through SMS with which the technical bid will be opened.
- v. The price bids will be opened after technical evaluation and **only the technically qualified bidders will be invited for opening of price bids** which shall also be conducted on online mode as above.
- vi. The contractors can also submit the quotations in sealed covers (Two-Bid) – as separate sealed covers for Technical Bid and Price bid, both enclosed in a common sealed cover to reach the below mentioned address before the stipulated time.
4. The bidders shall ensure the receipt of bids at contractcell@udupicsl.com An acknowledgement mail shall be sent to the bidders on receipt of bids. UCSL takes no responsibility for delay, loss or non-receipt of tenders by mail by the stipulated time.
5. The tender should be addressed to the **Assistant General Manager (Contract Cell), Udupi Cochin Shipyard Limited, Malpe Harbor Complex, Malpe, Udupi 576 108, Karnataka, India.**
6. No deviations on the tender conditions will be accepted, and bids with deviations will be considered technically disqualified. The acceptance of a tender or part thereof will rest with the Assistant General Manager (Contract Cell), Udupi Cochin Shipyard Limited and the authority reserve the right to reject the tender received without assigning any reason.
7. Contact Person: Mr. Akhil RP (+91 8129624149)

Assistant General Manager (Contract Cell)

**अखिल आर पी
AKHIL R P
प्रबंधक MANAGER
उडुपि कोचीन शिपयार्ड लिमिटेड
UDUPI COCHIN SHIPYARD LIMITED
माल्पे, कर्नाटक/MALPE, KARNATAKA-576 108**





UDUPI COCHIN SHIPYARD LIMITED
Tender For Fit up & Welding of Kort Nozzles, Stern Tube, Rudder Trunk, Stern Tube Cover Plate On
6300 DWT General Cargo Vessel
UCSL/CC/SB/T/175-182/241/2026 DT:08th Jun 2026

TERMS AND CONDITIONS

TENDER FOR FITUP & WELDING OF KORT NOZZLES, STERN TUBE, RUDDER TRUNK, STERN TUBE COVER PLATE ON 6300TDW GENERAL CARGO VESSEL

1. DESCRIPTION OF WORK

- 1.1. This tender enquiry pertains to the awarding of contract for Fit up & Welding of Kort Nozzles, Stern Tube, Rudder Trunk, Stern Tube Cover Plate of Total Eight (08) Nos of 6300TDW General Cargo Vessel to be built at Udupi Cochin Shipyard Limited (UCSL), Karnataka.
- 1.2. The work is to be carried out at Udupi Cochin Shipyard Limited (UCSL), at Hangarkatta, Udupi
- 1.3. You are requested to obtain clarifications, if any, and carefully study the documents and the scope of work of Contractor and UCSL, before submitting your offer.
- 1.4. The contractors are advised to familiarize themselves with the site conditions before quoting.
- 1.5. The work is to be carried out at the skid area allotted to the contractor(s) inside UCSL premises.

2. SCOPE OF WORK

- 2.1. The scope of work includes alignment, fit-up, welding, dry survey, and associated inspection activities for the Kort Nozzle, Stern Tube with Boss, and Rudder Trunk, including all applicable NDT requirements (DPT, UT Testing) and assistance for Post Weld Heat Treatment (PWHT), as required by the approved drawings, specifications, and classification society requirements.
- 2.2. The Contractor shall be responsible for the following activities:
 - a) Fit-up, welding, and dry survey inspection of the Kort Nozzle.
 - b) Fit-up, welding, and dry survey inspection of the Stern Tube and Boss assembly.
 - c) Fit-up, welding, and dry survey inspection of the Rudder Trunk.
 - d) Fit-up, welding, and dry survey inspection of the Stern Tube Cover Plate, including all associated closing plates.
- 2.3. Execution of all welding activities in accordance with approved welding procedures and applicable NDT requirements.
- 2.4. Deployment of qualified and approved welders with adequate experience in welding higher-thickness structural components.
- 2.5. Provision of necessary assistance and support for Post Weld Heat Treatment (PWHT) activities.
- 2.6. Performance of Dye Penetrant Testing (DPT), whenever required, using contractor-supplied consumables and equipment. All DPT results shall be presented to the UCSL representative for verification and acceptance.
- 2.7. Preparation of templates for closing plates to facilitate plate bending and fit-up activities.





UDUPI COCHIN SHIPYARD LIMITED
Tender For Fit up & Welding of Kort Nozzles, Stern Tube, Rudder Trunk, Stern Tube Cover Plate On
6300 DWT General Cargo Vessel
UCSL/CC/SB/T/175-182/241/2026 DT:08th Jun 2026

- 2.8. Provision of all required machinery, tools, tackles, welding equipment, consumables, measuring instruments, and accessories necessary for the satisfactory completion of the work.
- 2.9. Close coordination with the Machinery Department and continuous monitoring during fit-up and welding of the Stern Tube, Kort Nozzle, and Rudder Trunk to minimize and control weld-induced distortion.
- 2.10. Execution of work in accordance with the latest approved drawings, technical specifications, and instructions issued by UCSL.
- 2.11. Carrying out all necessary pre-heating, inter-pass temperature control, and post-heating of weld joints as specified in the approved welding procedures and applicable standards.
- 2.12. Structural pressure testing of the completed assemblies, including identification, rectification, and re-testing of any leakage or defects observed during testing, shall be within the Contractor's scope of work.
- 2.13. Fit-up, welding, and associated inspection activities related to the Rudder Trunk inspection hatch, including the closing plate and all related attachments, shall form part of the Contractor's scope.
- 2.14. Contractor shall provide their employees with all Personal Protective Equipment (PPE) such as safety helmets, gloves, welding shields, goggles, leg guards, safety belts, safety harness, safety aprons and safety shoes and shall ensure safety of personnel at the site at all times.
- 2.15. Reference Drawing:
 - i. UY175-3030
 - ii. UY175-3020

3. QUALIFICATION CRITERIA

- 3.1. The Bidder shall be a single firm having experience in Hull Erection in shipbuilding industries for minimum three (03) years.
- 3.2. The technical experience means "the experience of successfully completed similar works for period of 3 years. In the case of ongoing works, work progress report from the authorized officer of the work order issued firm shall be submitted for considering UCSL requirement.
- 3.3. The contractor must have a site-in charge/ supervisor to execute work, with a minimum experience of 3 yrs. in Hull field, also it is required to induct a HSE personnel for the project for monitoring and taking necessary work permit systems and allied HSE works.
- 3.4. If the experience claimed by the bidder is of no relevance with respect to Sl. no.3.1, then such experience will not be considered for pre-qualification. Decision taken by UCSL in this regard will be final.
- 3.5. The Bidder should furnish the required work-specific information and satisfactory documentary evidence such as copy of work order / agreement and a certificate from the employer for satisfactory completion of work or any other relevant document indicating completion of work shall be submitted to UCSL in support of its claim of experience, during the technical bid submission stage.
- 3.6. Bidder shall not be under a declaration of ineligibility issued by Govt. of India/ State govt./ Public Sector Undertakings etc. The bidder shall not have been debarred / black listed by UCSL or by any of the Public Sector Undertaking or Government department etc.

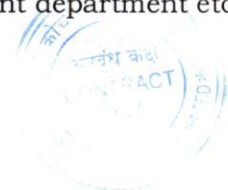



UDUPI COCHIN SHIPYARD LIMITED
Tender For Fit up & Welding of Kort Nozzles, Stern Tube, Rudder Trunk, Stern Tube Cover Plate On
6300 DWT General Cargo Vessel
UCSL/CC/SB/T/175-182/241/2026 DT:08th Jun 2026

4. METHOD OF AWARDING CONTRACT

- 4.1. Contract will be concluded with Bidder qualifying technically, agreeing to Techno-Commercial conditions (Annexure IV) and emerging as L1 based on Annexure - IV.
- 4.2. The bidder shall submit the prices at the Annexure - III and the same rates shall be applied to the for L1 determination.
- 4.3. Yard intends to award the total scope of work for 08 ship, out of which 02 ship is confirmed and remaining 06 ship as option based on the performance of the vendor.
- 4.4. In case of the contractor fails to perform at any stage of the project, the yard reserves the right to delink the individual scope of work and will award the same to alternate contractor. In such cases, the value shall be determined based price bid submitted which shall be deduction from the total contract value for payments.
- 4.5. The contractor shall indicate the fabrication lead time as per the requirement. However, the schedule as issued by the yard shall be final and binding which shall be reasonable and in line with the overall project schedule.
- 4.6. UCSL reserves the right to cancel the tender if required.

5. SCHEDULE OF COMPLETION

- 5.1. UCSL shall indicate the master construction schedule of completion of the work of vessel. The contractor in turn shall submit their detailed scheduled of completion of the work, in consultation with the officer In-charge. The progress of work shall be made in tandem with the progress of completion of the vessel allowing sufficient time for other interface activities/works.
- 5.2. Work must be completed within 25 days from the date of commencement of work order.
- 5.3. Yard has the right to change the schedules of the project to the interests of the company and the firm should be capable of adjusting the resources according to the instructions from the Yard contact person.
- 5.4. Detailed working schedule (Weekly/monthly) etc to be prepared and submitted to yard personnel. However, a detailed overall schedule, in a reasonable manner should be submitted prior to commencement of work.
- 5.5. Tentative Schedule as follow:

Sl. No.	Vessel No.	Tentative Date
1	UY.175	30-JUN-2026
2	UY.176	03-OCT-2026
3	UY.177	11-JAN-2027
4	UY.178	28-MAR-2027
5	UY.179	30-JUN-2027
6	UY.180	12-SEP-2027
7	UY.181	15-DEC-2027
8	UY.182	03-FEB-2028





UDUPI COCHIN SHIPYARD LIMITED
Tender For Fit up & Welding of Kort Nozzles, Stern Tube, Rudder Trunk, Stern Tube Cover Plate On
6300 DWT General Cargo Vessel
UCSL/CC/SB/T/175-182/241/2026 DT:08th Jun 2026

6. VALIDITY

6.1. The offer shall be valid for a period of 01 year and no escalation in rate shall be allowed by UCSL on whatsoever reason.

7. RATE

7.1. Rates are to be quoted in the Price Bid Format at Annexure-III attached herewith.

8. PAYMENT TERMS

- 8.1. 100% Payment shall be made per vessel based on certification by UCSL Quality Control Representative for the quality and quantity of work on actuals.
- 8.2. The payment shall be made within 30 days from submission of invoice along with the work completion certificate.
- 8.3. All claims for payment for the work/additional work shall be submitted by the contractor within one month of completion of work.
- 8.4. Payment will be made by RTGS/NEFT to the account of Contractor. The name of the bank, branch, A/C No., IFSC code & other particulars shall be furnished by the Contractor in the proforma of UCSL.

9. TAXES & DUTIES

- 9.1. GST shall be applicable extra on the prescribed work. You are requested to furnish the following details in the invoice/Bill.
- Applicable rate of GST/SAC Code
 - Firms GST Reg. NO.
 - Service accounting code (SAC) as prescribed by statutory authorities.
 - GST Reg. No. of Udupi Cochin Shipyard Limited(29AAACT1281B1ZO).

10. PERIOD OF CONTRACT & COMMENCEMENT OF SERVICES

10.1. Period of contract will be as per schedule from the date of work order. The rates quoted and all other terms and conditions will remain unchanged for the entire period and also for the extended period (if extended).

11. LIQUIDATED DAMAGES

- 11.1. The progress of work will be monitored against the mutually agreed detailed schedule. Liquidated damages for delays in execution of the work beyond the scheduled date of completion, for any reason other than force majeure conditions, will be recovered at the rate of half percent of the value of the contract per week or part thereof, subject to a maximum of ten (10) percent of the value of the contract.
- 11.2. For better clarity, order values mentioned in LD clause are values excluding duties and taxes (Basic value). Liquidated damages, if any, shall be decided and settled only after the completion of the entire project but prior to the release of Final stage Payment.





UDUPI COCHIN SHIPYARD LIMITED
Tender For Fit up & Welding of Kort Nozzles, Stern Tube, Rudder Trunk, Stern Tube Cover Plate On
6300 DWT General Cargo Vessel
UCSL/CC/SB/T/175-182/241/2026 DT:08th Jun 2026

- 11.3. If, for any reasons, supplier has a justification towards delay in supply / work execution and would intend to consider applicability/ non applicability of LD, the same shall be intimated to UCSL by way of a letter, failing which it will be deemed that delay is attributable to the supplier.
- 11.4. Delay in supply/Interruption of the work for reasons not attributable to supplier shall entitle extension of the order execution period for proportionate period without any additional cost to UCSL.

12. POWER OF ATTORNEY

- 12.1. The tenderer(s) shall have to sign in each page of the tender documents with official stamp as a token of his acceptance of the conditions stated therein.
- 12.2. The person signing the tender form on behalf of another or on behalf of a firm, shall enclose to the tender, a Power of Attorney or the said deed duly executed in his favour or the partnership deed giving him such power showing that, he has the authority to bind such other persons or the firm, as the case may be, in all matters pertaining to the contracts. If the Person so signing the tender, fails to enclose the said Power of Attorney, his tender shall be liable for being summarily rejected. The Power of Attorney shall be signed by all partners in the case of partnership concern, by the Proprietor in the case of a proprietary concern, and by the person who by his signature can bind the company in the case of a Limited Company.

13. TERMINATION & LIMITATION OF LIABILITY

- 13.1. This contract may be terminated upon the occurrence of any of the following events
- 13.2. By agreement in writing of the parties hereto;
- 13.3. By the non-defaulting party, upon default by the other party, of any clause of this contract, if not remedied within fifteen (15) days, or such longer time as may be agreed upon by the parties, after receipt of notice thereof in writing from the non-defaulting party;
- 13.4. By the other party, upon either party;
- i. Making the assignment for the benefit of creditors, being adjudged a bankrupt or becoming insolvent; or
 - ii. Having a reasonable petition filed seeking its' dissolution or liquidation, not stayed or dismissed within sixty (60) days; or
 - iii. Ceasing to do business for any reason.
- 13.5. For fraud and corruption or other unacceptable practices.
- 13.6. Upon expiry or termination of this Contract, neither party shall be discharged from any antecedent obligations or liabilities to the other party under this Contract unless otherwise agreed in writing.





UDUPI COCHIN SHIPYARD LIMITED
Tender For Fit up & Welding of Kort Nozzles, Stern Tube, Rudder Trunk, Stern Tube Cover Plate On
6300 DWT General Cargo Vessel
UCSL/CC/SB/T/175-182/241/2026 DT:08th Jun 2026

- 13.7. UCSL may by notice in writing to Contractor to terminate the order after issuing due notice i.e., 30 days' notice period. UCSL shall be entitled to compensation for loss limited to the order value.
- 13.8. Liability maximum that can be claimed by the Contractor shall be limited to what is due to be and has been paid by UCSL for work done as per the payment milestones and limited to work order value.

14. ARBITRATION & JURISDICTION

- 14.1. Any disputes arising during the period of the contract shall, in the first instance be settled by mutual discussions and negotiations. The results of such resolution of dispute shall be incorporated as an amendment to the contract, failing which supplier shall approach the UCSL Grievance Redressal Committee as per relevant clause of the Contract.
- 14.2. If any dispute, disagreement or question arising out of or relating to or in consequence of the contract, or to its fulfillment, or the validity of enforcement thereof, cannot be settled mutually or the settlement of which is not herein specifically provided for, then the dispute shall within thirty days from the date either party informs the other in writing that such disputes, disagreement exists, be referred to arbitration. The arbitrators shall be appointed and the arbitration proceedings shall be conducted in accordance with and subject to the Arbitration and Conciliation Act, 1996 (No. 26 of 1996) as amended from time to time and the decision of the Arbitrators shall be final and binding on the parties hereto. The arbitration will be done by a Board comprising one arbitrator nominated by each party, and a mutually agreed Umpire. Each party shall bear its own cost of preparing and presenting its case. The cost of arbitration shall be shared equally by the parties unless the award provides otherwise. Performance under this Contract shall however, continue during arbitration proceedings and no payment due or payable by the parties hereto shall be withheld unless any such payment is or forms a part of the subject matter of arbitration proceedings.
- 14.3. Seat & Venue of Arbitration: The seat & venue of arbitration shall be at Bangalore.
- 14.4. Language of Arbitration: The Language of arbitration shall be English.
- 14.5. Governing Law: The contract shall be governed by Indian Law
- 14.6. In case of disputes, the same will be subjected to the jurisdiction of courts at Bangalore, Karnataka.

15. SUB CONTRACTING AND ASSIGNMENT

- 15.1. Contractor shall not assign or transfer the Purchase Order/ Work Order or any share or interest therein in any manner or degree to any third party without the prior written consent of UCSL.
- 15.2. Contractor shall not contract with any subcontractor and/or vendor without the prior written consent of UCSL. Such consent shall not relieve the Contractor from any of his responsibilities and liabilities under the Purchase Order/ Work Order. In addition, Contractor shall ensure that the terms and conditions of any such

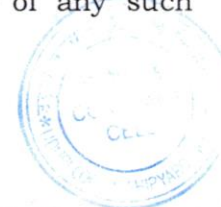



UDUPI COCHIN SHIPYARD LIMITED
Tender For Fit up & Welding of Kort Nozzles, Stern Tube, Rudder Trunk, Stern Tube Cover Plate On
6300 DWT General Cargo Vessel
UCSL/CC/SB/T/175-182/241/2026 DT:08th Jun 2026

contract shall comply with and correspond to the terms and conditions of the Purchase Order/ Work Order.

16. SECRECY & RESTRICTION ON INFORMATION TO MEDIA

- 16.1. The information contained in the enquiry as such shall NOT be communicated to any third party without prior approval of UCSL.
- 16.2. Information in respect of contracts/orders shall NOT be released to the national or international media or anyone not directly involved in its execution without the written approval of UCSL

17. CANCELLATION OF ORDER AND RISK CONTRACTING

- 17.1. In the event the Contractors fails to complete the work promptly and satisfactorily as per the terms of the order, and if any work is delayed beyond thirty (30) days from the agreed schedule, UCSL, without prejudice, reserves the right to cancel the order and get the work done at Contractor's cost and the expenditure so incurred including any damage or loss will be recovered from him and the Security Deposit furnished by him is liable to be forfeited either in whole or in part.
- 17.2. UCSL also reserves to right to impose penalties ranging from Rs. 100 to Rs.500 to the employees of contractors and will be deducted from the bills, for any habitual offence on the cleanliness of uniforms, lack of obedience, not attending the tasks etc., and will be to the discretion of the Officer in charge for the work.

18. FORCE MAJEURE

- 18.1. Should failure in performance of any part of this contract arise from war, insurrection, restraint imposed by Government act or legislation of other statutory authority, from explosion, riot, legal lock-out, flood, fire, act of God or any inevitable or unforeseen event beyond human control which will be construed as a reasonable ground for extension of time, UCSL may allow such additional time as is mutually agreed to be justified by the circumstances of the case.

19. SAFETY OF PERSONNEL AND FIRST AID

- 19.1. The contractor shall be entirely responsible for the safety of all the personnel employed by him on the work. In this regard, he may adopt all the required safety measures and strictly comply with the safety regulations in force. A copy of UCSL's "Safety Rules for Contractors (Revised)" is available with HSE department for reference.
- 19.2. The Contractor may arrange to suitably insure all his workmen/ other personnel in this regard. UCSL will not be responsible for any injury or illness to the Contractor's workmen/other personnel during execution of the works due to whatsoever reasons.
- 19.3. In this regard, the Contractor will have to fully indemnify UCSL against any claims made by his workmen/other personnel
- 19.4. The Contractor shall provide and maintain so as to be readily accessible during all working hours, a first aid box with prescribed contents at every place where he employs contract labor for executing the works.





UDUPI COCHIN SHIPYARD LIMITED

Tender For Fit up & Welding of Kort Nozzles, Stern Tube, Rudder Trunk, Stern Tube Cover Plate On
6300 DWT General Cargo VesselUCSL/CC/SB/T/175-182/241/2026 DT:08th Jun 2026**20. IMS GUIDELINES**

20.1. UCSL implemented an Integrated Management System (IMS) and the Quality Management System (QMS) within the yard. As part of IMS, subcontractors shall comply with the following measures related to the Quality, Health, and Safety & Environment (QHSE) policy of UCSL.

- a) Meeting or exceeding customer requirements.
- b) Assuring quality of the products and service.
- c) Preventing occupational ill health & injuries.
- d) Ensuring safe work sites.
- e) Conserving natural resources.
- f) Preventing / minimizing air, water & land pollution.
- g) Handling and disposal of Hazardous wastes safely.
- h) Complying with statutory & regulatory and other requirements.
- i) Developing skills and motivating employees.

20.2. Occupational Health, safety & Environmental requirements of UCSL shall also include the following.

- a) The contractor (or a sub-contractor performing work on behalf of the contractor) is deemed to comply with the Occupational health, safety and environmental policy of the company and also to all operational controls/standard operating procedures and shall undertake the work in total compliance with the requirements of the established Integrated Management System (IMS) of the company.
- b) The Contractor shall undertake the work in total compliance with all applicable legal/statutory requirements related to occupational health, safety and environment effective in the state of Kerala.
- c) It is the sole responsibility of the contractor to assure that any sub-contractor/s who shall perform works in company lands/facilities/worksites on behalf of the contractor, is also following all requirements related to the Integrated Management System of the company and the health/safety/environmental Rules effective in the state.
- d) The contractor shall provide/implement and operate/practice all occupational health, safety and environmental management measures/facilities, for their period of contract, in their activities/at their work sites, which shall be required according to the IMS of the company or that required by the health/safety/environmental Rules established and effective in the state, at their own cost.
- e) If any contractor failed to comply with or violated any clauses/requirements of occupational health, safety and environmental Rules effective in the state, in their activities or at work sites and the same shall be exposed to the government or any competent authorities upon inspections, the contractor shall be solely responsible for all liabilities caused by his/her action and shall be responsible for





UDUPI COCHIN SHIPYARD LIMITED
Tender For Fit up & Welding of Kort Nozzles, Stern Tube, Rudder Trunk, Stern Tube Cover Plate On
6300 DWT General Cargo Vessel
UCSL/CC/SB/T/175-182/241/2026 DT:08th Jun 2026

paying the penalty and taking stipulated corrective actions insisted by the authorities within the specified time, at their own cost. Any liability to the company in this regard needs to be compensated by the contractor.

- f) Upon completion of the work, contractor shall clear the area and shall not leave any Occupational health/safety/environmental liabilities to the company, from their activities at the worksites.
- g) Any clarification related to IMS requirements of the yard, may be obtained by the contractor from the AGM (HSE) or the authorized representative of the contract, prior to the commencement of work.

21. LABOUR LAWS AND REGULATIONS

- 21.1. The Contractor shall undertake and execute the work with contract Labor only after taking license from the appropriate authority under the Contract Labor (Regulation & Abolition) Act 1970.
- 21.2. The Contractor shall observe and comply with the provisions of all labour and industrial laws and enactments and shall comply with and implement the provisions of the Factories Act, 1948, Employees Provident Funds & Miscellaneous Provisions Act, 1952, Employees State Insurance Act, Payment of Gratuity Act, minimum Wages Act, Payment of Bonus Act, Contract Labour (Regulation and Abolition) Act and all other enactments as are applicable to him and his workmen employed by him. The Contractor shall inform UCSL his license number from the Central Labour Commissioner.
- 21.3. All Persons, except those exempted under the respective Acts, shall necessarily be insured under the ESI scheme and be made members of the EPF Scheme from the day of their engagement as personnel in the Company. In Case 1, All such insured Persons should carry with them their ESI Identity Card for verification by the authorities. No Persons without a valid ESI Identity Card for verification by the authorities will be permitted to work in the company.
- 21.4. The Contractor shall submit the Labour Reports/Returns as required by the Company from time to time in respect of their workmen in standard format to the concerned contracting officer so as to enable the same to reach Contract cell by the 5th of every month. Delayed submission of the same shall attract penal interest /damages at the rate as levied by the respective authorities under the relevant Acts.
- 21.5. The Contractor shall maintain the records viz. Muster Roll, Acquittance Roll with full details, Account books etc., in original. These are required for inspection by the concerned authorities under each scheme.
- 21.6. If the Contractor fails to pay any contributions, charges or other amounts payable under any of the aforementioned provisions of law, UCSL shall deduct or adjust amounts equivalent to such contribution, charges or amounts from amount payable to him by UCSL, including any deposit or amounts payable against bills and make payments on his account to the appropriate authority. He shall not be entitled to question or challenge such deductions, adjustments or payment made by UCSL.
- 21.7. Any other amount payable under any law or in respect of any person employed by the Contractor, if not paid by him, shall be deducted or adjusted by UCSL out of any amount payable to the Contractor including any Security Receipt and paid ever or withheld for payment by UCSL.





UDUPI COCHIN SHIPYARD LIMITED
Tender For Fit up & Welding of Kort Nozzles, Stern Tube, Rudder Trunk, Stern Tube Cover Plate On
6300 DWT General Cargo Vessel
UCSL/CC/SB/T/175-182/241/2026 DT:08th Jun 2026

- 21.8. The Contractor shall be fully responsible for the conduct and discipline of the workmen employed by him in the Company premises. If such workmen commit any misconduct or criminal act inside the Company, the Contractor shall take appropriate action against such workmen. The Contractor shall abide by the instructions/ guidelines issued by the Company for maintenance of discipline and good conduct among the workmen employed by him.
- 21.9. All persons who are engaged for various works in UCSL either directly or through Contractor, should produce the following documents prior to issuing their entry passes:
- 21.10. Passport/Aadhaar attested copy of passport with photo and address particulars. OR
- 21.11. Police clearance certificate with photo and address particulars. (Police clearance certificate to the effect that the concerned person is staying in the area of jurisdiction of the certificate issuing Police Station and that the person is not involved in any criminal offences as per the records available therein.)
- 21.12. Application and Declaration for enrolling under Employees Provident Fund and ESI Scheme- 3 individual passport size photographs and two copies of family photographs of the members.
- 21.13. Contractor shall familiarize themselves with the labour rules & regulations.

22. OVERWRITING & CORRECTIONS

- 22.1. Tenders shall be free from overwriting or erasures. Corrections and additions, if any, shall be duly attested and a separate list of such corrections shall be attached with the offer

23. OTHER TERMS & CONDITIONS

- 23.1. Quality of services shall conform to the specification/ standards laid down by UCSL.
- 23.2. UCSL reserves the right to accept / reject any offer.
- 23.3. UCSL reserves the right to award the work to more than one contractor or to take over partially or fully the work depending upon the schedule requirements.
- 23.4. During the evaluation of tender, officer-in-charge may seek clarifications from the bidders. Clarification if any shall be given in writing/e-mail. Officer-in-charge's decision will be final and binding on the bidder.
- 23.5. Compliance of all statutory safety requirements and other safety rules stipulated by UCSL and other applicable statutory bodies shall be the responsibility of the Contractor while working at UCSL premises. The Contractor should ensure that their workmen and staff are adequately covered under Insurance.
- 23.6. Damages caused to the Shipyard properties/tools/accessories should be rectified by the Contractor at his cost or proportional recoveries will be made from the Contractor while passing their bills for payment.
- 23.7. The service provider shall have to engage men on round the clock basis and also on Sundays and holidays. Service has to be completed to the satisfaction of Udupi Cochin Shipyard Limited officer in-charge.
- 23.8. The service provider shall indemnify UCSL or its officers against any claims arising out of accidents or injuries to workmen or other persons or damage to other

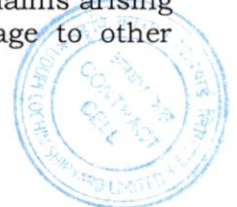



UDUPI COCHIN SHIPYARD LIMITED
Tender For Fit up & Welding of Kort Nozzles, Stern Tube, Rudder Trunk, Stern Tube Cover Plate On
6300 DWT General Cargo Vessel
UCSL/CC/SB/T/175-182/241/2026 DT:08th Jun 2026

- property which may arise during the execution of the contract or from breach of any Law or Regulation prior to delivery and acceptance of the items at UCSL.
- 23.9. The service provider shall also be governed by the General Conditions of Contract of UCSL, General Safety Rules and other relevant labour laws.
- 23.10. The upper age limit of all workers and supervisors employed by the Contractor and those Contractor who do or supervise the job themselves shall be as per the prevailing rules of UCSL and shall comply to the requirements of this tender.
- 23.11. Work to be carried out through Indian Citizen only.
- 23.12. Assistant General Manager, or his authorized representative will be the Officer-in-charge of these contracts.



POWER OF ATTORNEY

(On Applicant's letter head)

(Date and Reference)

To
The Assistant General Manager (Contract Cell)
Udupi Cochin Shipyard Limited
Fishing Harbour complex, Malpe,
Udupi - 576 108.

Subject: Power of Attorney

Mr. / Mrs. / Ms..... (Name of the
Person(s)), domiciled
at.....(Addre
ss), acting as..... (Designation and name of the
company), and whose signature is attested below, is hereby appointed as the Authorized
Representative and authorized on behalf of.....
(Name of the company) to provide information and respond to enquiries etc. as may be required
by the Employer for the project of
(Project title) and is hereby further authorized to sign and file relevant documents in respect of
the above.

(Attested signature of Mr.)

For.....
(Name & designation)

(Company Seal)





UDUPI COCHIN SHIPYARD LIMITED
 Tender For Fit up & Welding of Kort Nozzles, Stern Tube, Rudder Trunk, Stern Tube Cover Plate On 6300
 DWT General Cargo Vessel
 UCSSL/CC/SB/T/175-182/241/2026 DT:08th Jun 2026

PRICE BID FORMAT

TENDER FOR FITUP & WELDING OF KORT NOZZLES, STERN TUBE, RUDDER TRUNK, STERN TUBE COVER PLATE ON 6300TDW GENERAL CARGO VESSEL			
SLNO	DESCRIPTION	UOM	Total Amount
1	Fit-up, Alignment, Welding, and dry survey Inspection of Kort Nozzle, Stern Tube with Boss, Rudder Trunk, and Stern Tube Cover Plate for 6300 TDW General Cargo Vessel	LS	
2	IGST/GST @.....		
3	GRAND TOTAL		

Note:

- 1.1. Prices are to be quoted in the Pricing Format. The quotations to be submitted in the company letter head and forwarded to contractcell@udupicsl.com
- 1.2. Quotations shall be submitted as Password Protected File. The bidders are advised to share the password through only SMS while opening the quotations.
- 1.3. L1 will be determined based on the total amount at Sl no.3.

Signature:

Address of the contractor:

Seal:





UDUPI COCHIN SHIPYARD LIMITED
Tender For Fit up & Welding of Kort Nozzles, Stern Tube, Rudder Trunk, Stern Tube Cover Plate On
6300 DWT General Cargo Vessel
UCSL/CC/SB/T/175-182/241/2026 DT:08th Jun 2026

ANNEXURE-IV
TECHNO COMMERCIAL CHECK LIST (To be submitted by the bidder)

(Bidders may confirm acceptance of the Tender Conditions/deviations if any to be specified)

SL No.	Tender Enquiry Requirements	Confirmation from bidder (Strike off whichever is not applicable)	Specific comments /Remarks
1	Terms & Condition, Scope of work (Annexure-I)	Agreed as per tender /Do not agree	
2	Schedule Clause 5.1 ,5.2,5.3,5.4 & 5.5	Agreed as per tender/Do not agree	
3	Eligibility criteria documents	Submitted/Not submitted	
4	Unconditional Acceptance	Agreed as per tender/Do not agree	
5	Offer Validity	01 Year - Agreed as per tender/Do not agree	
6	Taxes & Duties	Specified/included in Price	
7	Payment terms - confirm		
a	As per Clause 8 of Annexure - I	Agreed as per tender/Do not agree	
8	Price shall remain firm and fixed and No Escalation in prices after awarding of contract	Agreed as per tender/Do not agree	
9	Security Deposit	Agreed as per tender/Do not agree	
10	Performance Guarantee	Agreed as per tender/Do not agree	
11	Force Majeure	Agreed as per tender/Do not agree	
12	Liquidated damages and cancellation of contract	Agreed as per tender/Do not agree	
13	Arbitration & Jurisdiction clauses	Agreed as per tender/Do not agree	
14	Confirm all other terms and conditions of our enquiry are acceptable.	Confirmed/Not confirmed	
15	Deviations from Tender conditions	No Deviations	

Signature:

Address of the Contractor:

Seal:



UNCONDITIONAL ACCEPTANCE LETTER

(Unconditional acceptance to be given by in letter head)

ACCEPTANCE OF TENDER CONDITIONS

Tender Document no. UCSL/CC/SB/T/175-182/241/2026 DT: 08th Jun 2026
Tender For Fit up & Welding of Kort Nozzles, Stern Tube, Rudder Trunk, Stern
Tube Cover Plate On 6300 DWT General Cargo Vessel at UCSL has been received
by me/us and I/We hereby unconditionally accept the tender conditions of tender
documents in its entirety for the above work.

It is further noted that it is not permissible to put any remarks/conditions in the
tender enclosed in "Part-2 (price bid)". I/We agree that the tender shall be
rejected and ACCEPTING AUTHORITY.

Yours faithfully,

(Signature of the tenderer) with rubber stamp

Date:



Top view section 8100 ABL

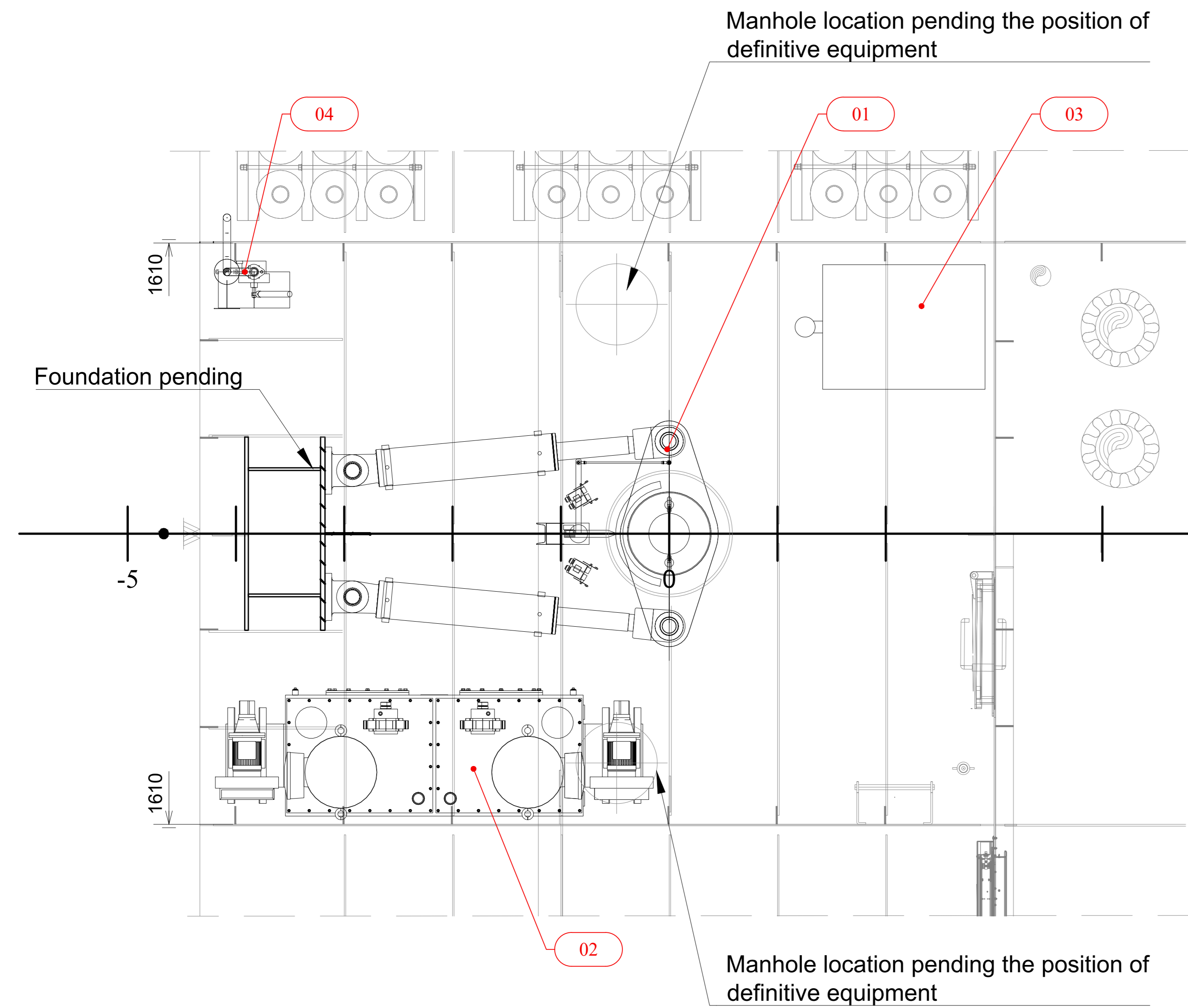

View Fr.0

Looking Aft

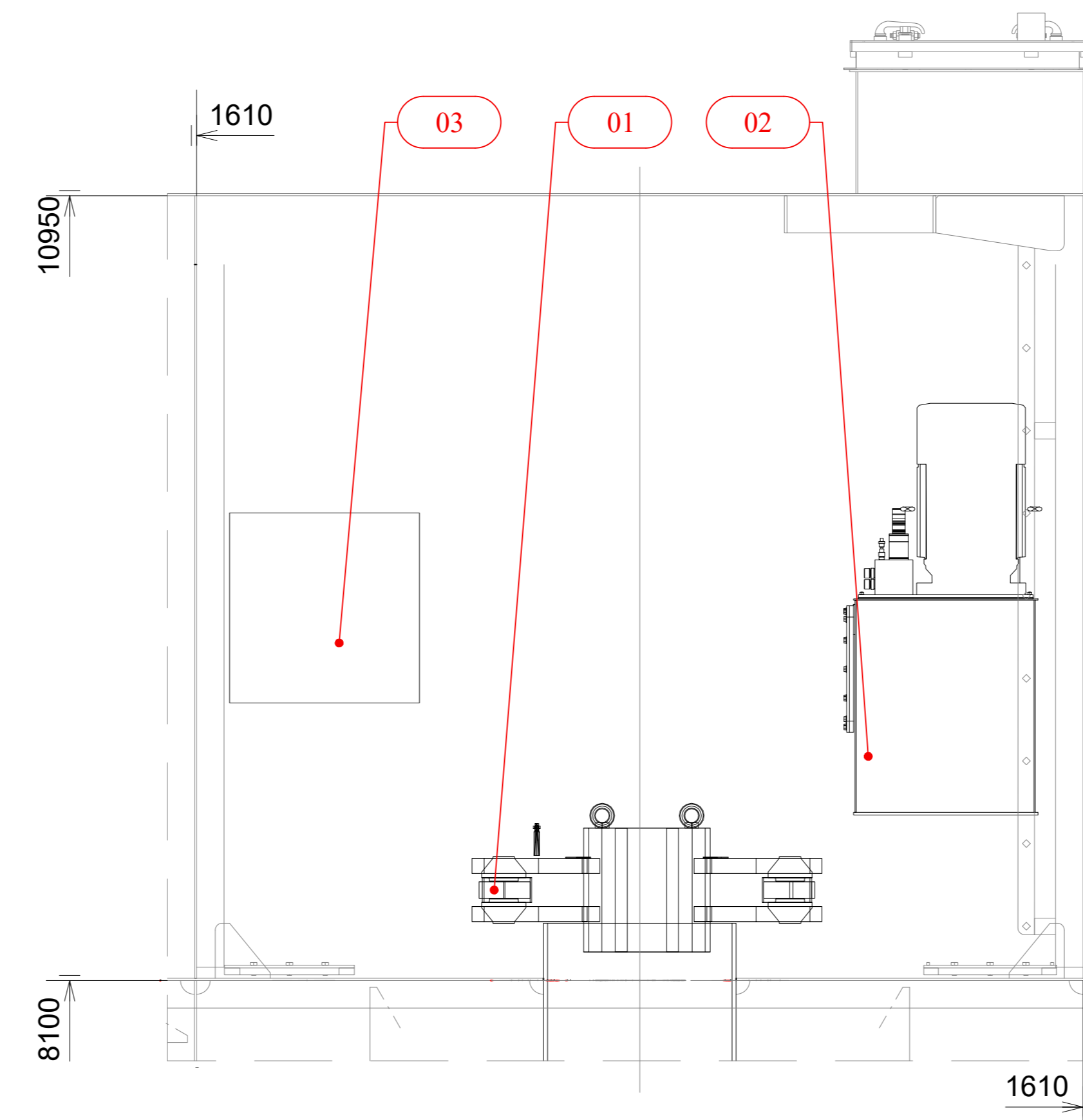

View section at C.L.

Looking to PS

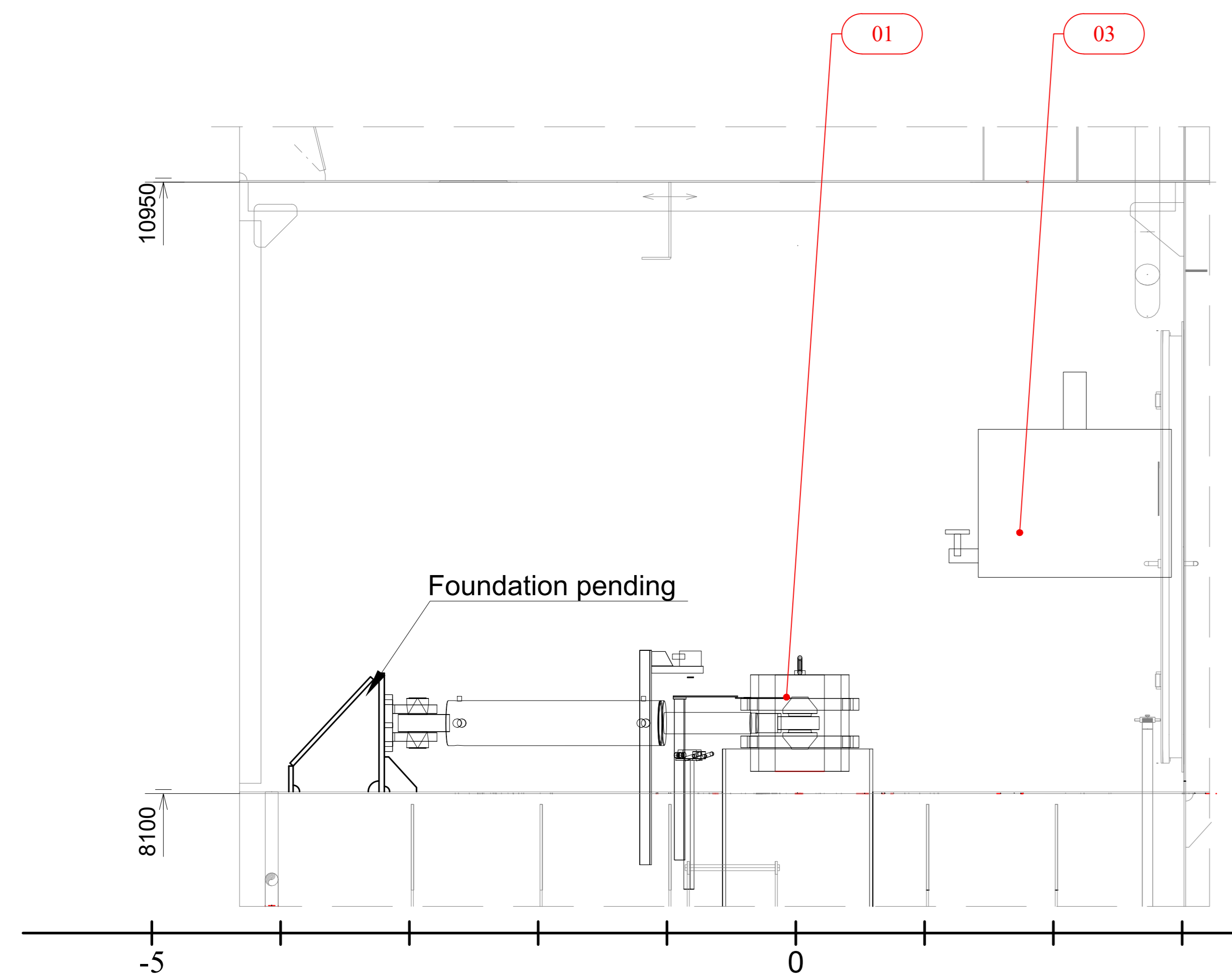

Main components Steering gear room (3001)					
Pos nr.	Description	Make	Type	Capacity.	Weight [kg]
01	Steering gear	-	-	-	-
02	Steering gear HPU	-	-	-	-
03	Storage tank	-	-	-	-
04	Hand vane pump	-	-	-	-



REFERENCES DRAWINGS:

- UY175-1001-General Arrangement
- UY175-1002-Tank Arrangement
- UY175-2031-Construction plan aft shi
- UY175-3041-Ladders and stairs arrangement
- UY175-3042-Arrangement small hatches and ventilation openings

NOTES:

- The type of equipment item 01-04 will be provided once data is obtained
- Drawings show preliminary make and location.
- Final equipment could differ, but should have similar specs.

REV	DATE	MADE BY	APPROVED BY	DESCRIPTION
<small>COPYRIGHT CONOSHIP INTERNATIONAL B.V. 2009. All rights reserved. This document or any part thereof may not be made public or disclosed, copied or otherwise reproduced or used in any form or by any means, including, but not limited to, use hereof for the design and manufacturing of identical, similar or derived designs, nor identical, similar or derived documents and specifications, without prior written consent of Conoship International B.V. P.O.Box 6029 - GRONINGEN - THE NETHERLANDS</small>				
DRAWING NO. UY175-3020				
DESCRIPTION Steering Gear Room Arrangement				
SCALE	SIZE:	YARD NO.	VERSION:	SHEET:
1:25	A1	UY175	00	1-1
DRAWN BY:	DATE:	APPROVED BY:	DATE:	
JO	29-11-2024	GP	29-11-2024	

Long. section in C.L.

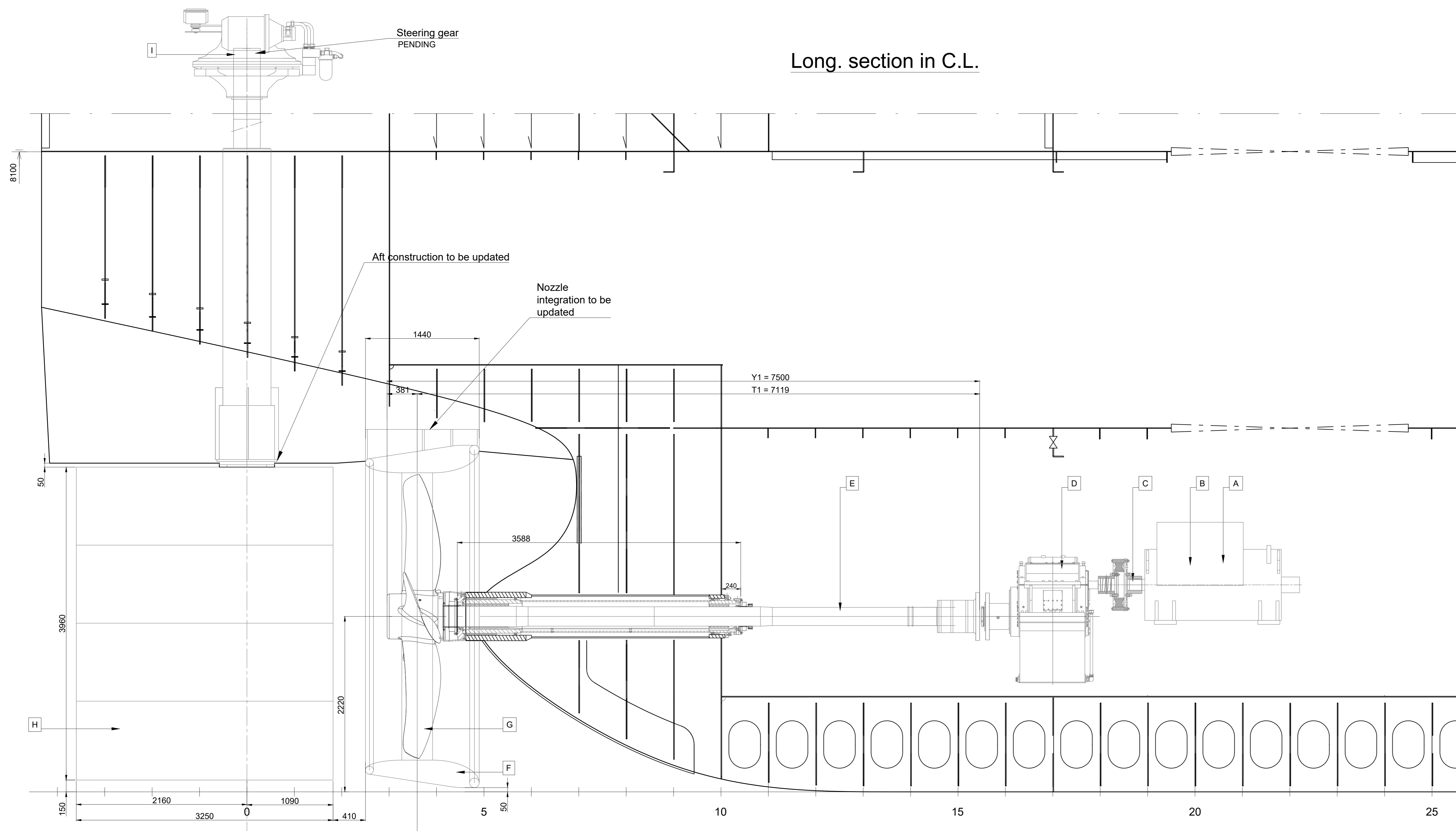

Top view 2600/1200 above base

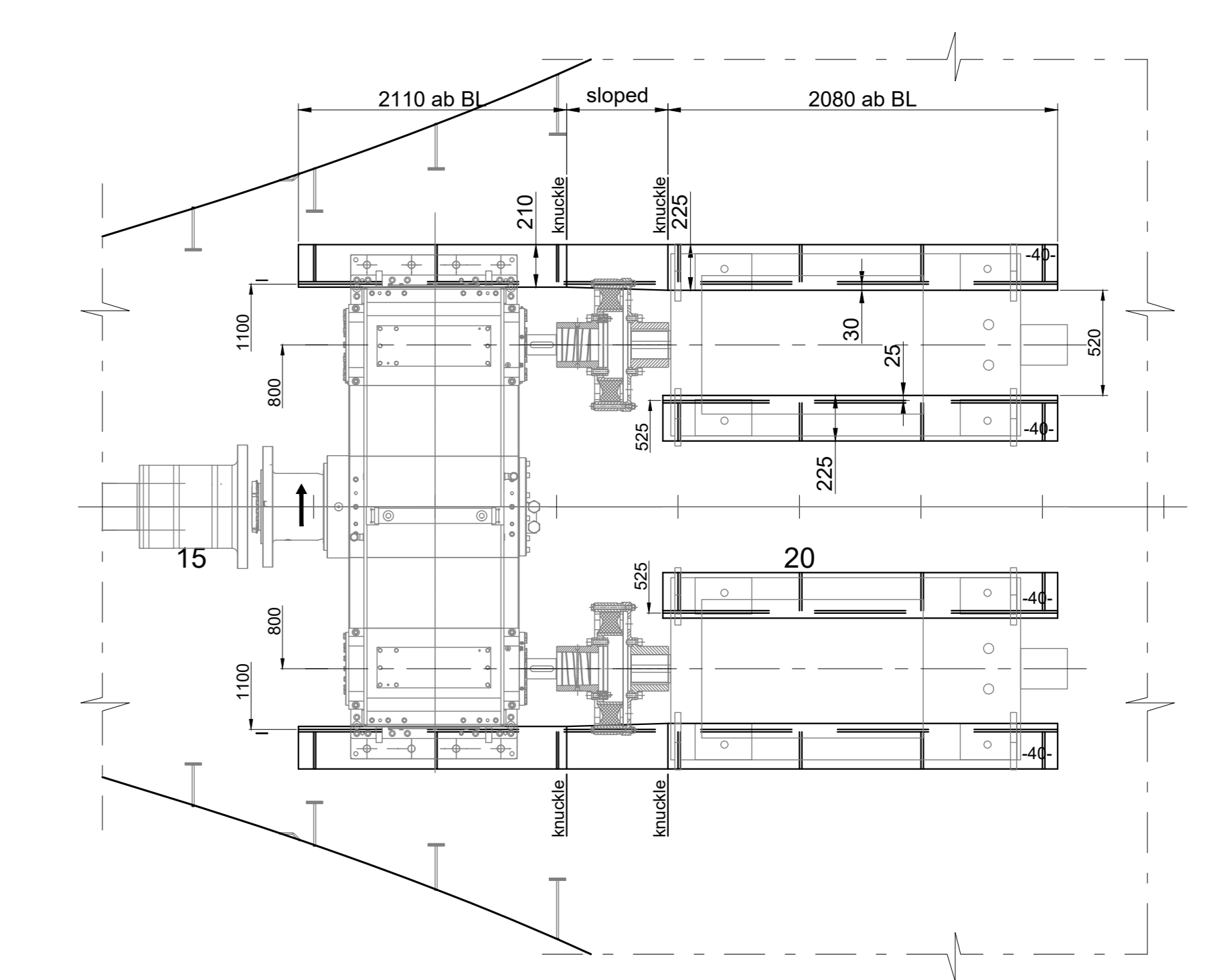

Long. section 1100 off C.L. PS
Similar in SB

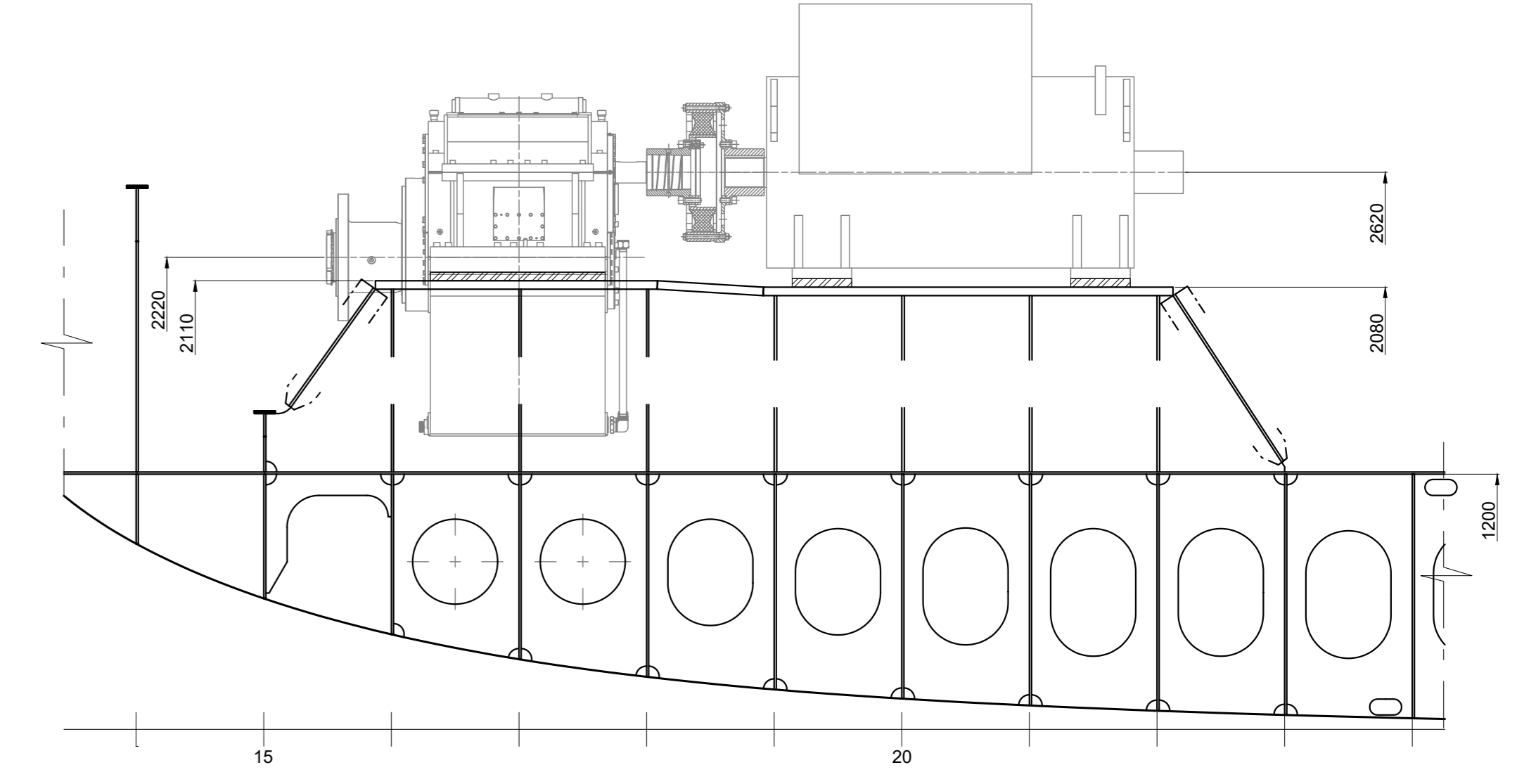

Frame 17

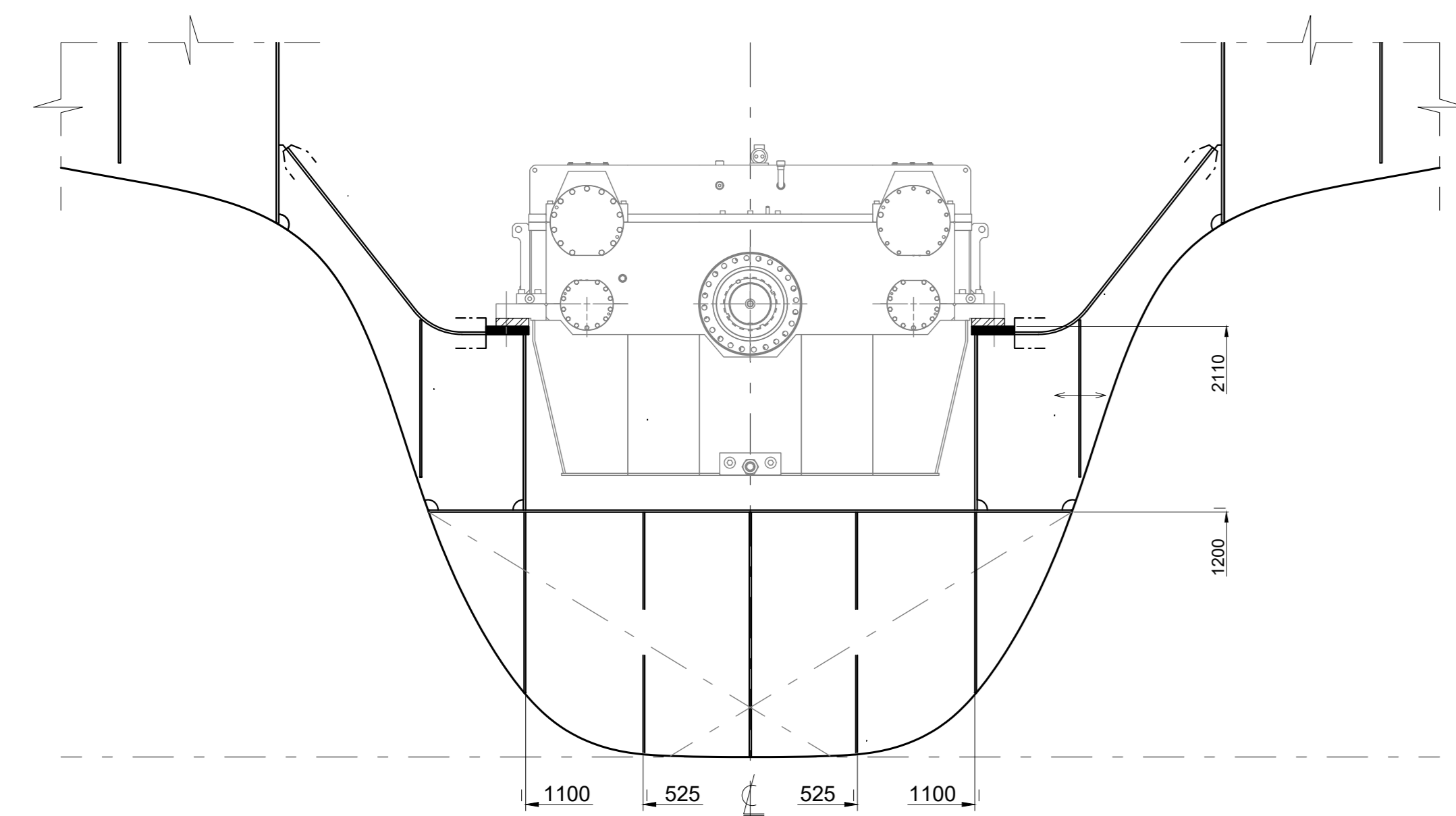

Frame 20

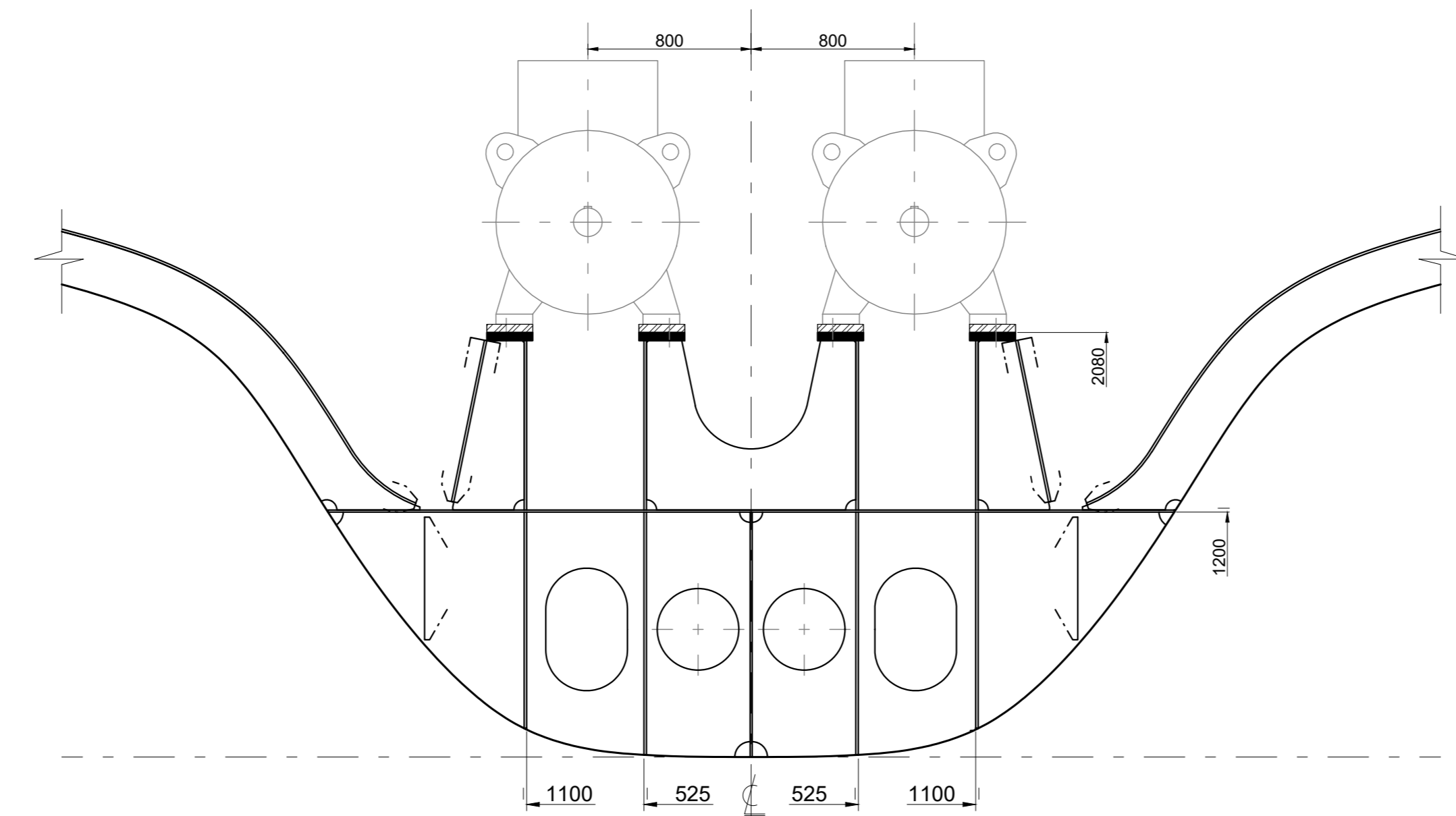

Long. section 525 off C.L. PS
Similar in SB

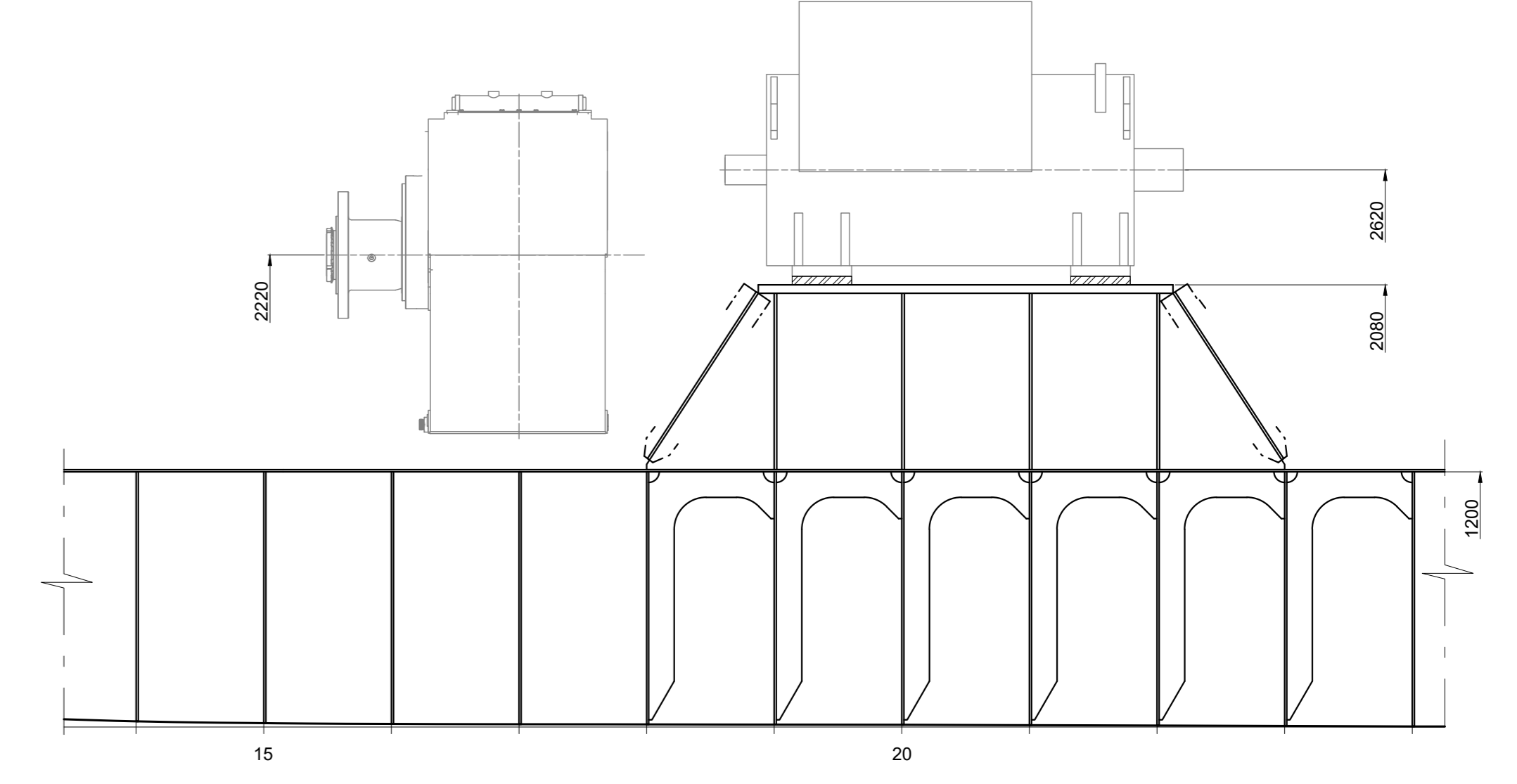

COMPONENTS						
Pos.	Description	Maker	Type	Capacity	Weight [kg]	REMARKS
A	E-motor PS	-	-	650 kW	-	-
B	E-motor SB	-	-	650 kW	-	-
C	Flexible coupling	-	-	-	-	-
D	Prop. Gearbox	-	-	-	-	Single step, reduction ratio : 9.6
E	Shaft line	-	-	-	-	Length : 7500mm, Nominal RPM : 104, max RPM: 125
F	Nozzle	-	-	-	-	Inside diameter : 3636mm, Profile length: 1400mm
G	Propeller	-	-	Ø 3600 mm	-	4 blades FPP, max speed : 125 rpm Direction of rotation: Counter clockwise (seen from aft)
H	Rudder	-	-	-	-	Type: free hanging balanced rudder, Span: 3960mm, Chord: 3250mm, Spade: 1073mm
I	Steering gear	-	-	-	-	RAM-type, hydraulic operated steering gear with separate HPU unit, Nominal torque: min 150 kNm

- NOTES:
- Dimensions and type of components are pending.
 - The dimensions of the flexible couplings are determined by Supplier after the torsional calculation;
 - Detailed information about the foundations see drawing : UY175-2071-*Foundation electro motor(s) and gearbox*
 - Drawing shows prel. equipment, to be updated.

CONOSHIP
DRAWING NO. UY175-3030
DESCRIPTION
Propulsion train arrangement (incl. principle rotations)
SCALE 1:25 SIZE A0 YARD NO. UY175 VERSION: 00 SHEET: 1-1
DRAWN BY: JO DATE: 14-11-2024 APPROVED BY: GP DATE: 14-11-2024