



## TENDER ENQUIRY

Description : SUPPLY & INSTALLATION OF SANDWICH PUF PANELS FOR TFV.01-20

Tender Information:

Dear Sirs,

Sealed tenders in duplicate, superscribing the enquiry number and last date for receipt of quotations on the envelope, are invited in **two separate/ single covers as Part - I : "Techno - commercial (un priced)" and Part - II : "Price"** for the supply of following materials/ services so as to reach the undersigned on or before the last date and time shown. Tenders should be addressed to "The Deputy General Manager (Materials), Cochin Shipyard Ltd., P.B. No.1653, Cochin - 682 015, Kerala, India". Tenders will be considered subject to the General Terms and Conditions attached.

Enquiry No: MAT/CSH-6/0323/21-22	LAST DATE OF RECEIPT OF TENDER	TENDER OPENING DATE
Enquiry date: 15 Jun 2021	29 Jun 2021	29 Jun 2021
Dept. : Materials/ Purchase	TIME: 15.00 HRS. IST	TIME: 15.30 HRS. IST

Sl. No.	Description	Qty	Unit	Required Date
1	SUPPLY & INSTALLATION OF SANDWICH PUF PANELS FOR FISH HOLD	20	SET	TFV.01-TFV.05 : 01 OCT 2021
				TFV.06-TFV.10 : 15 NOV 2021
				TFV.11-TFV.15 : 31 DEC 2021
				TFV.16-TFV.20 : 31 JAN 2022

### Annexure for Tender Enquiry:

1. Eligibility Criteria
2. Purchase Technical Specification
3. General Terms & Conditions
4. Price bid format
5. Bank Guarantee format
6. Pre-Contract Integrity Pact

Yours faithfully,

Authorised Signatory

रोबिन चेरियान  
ROBIN CHERIAN  
प्रबंधक  
Manager  
कोचीन शिपयार्ड लिमिटेड  
Cochin Shipyard Ltd.  
कोच्ची / Kochi - 15

### For any Clarification, Please Contact:

E-mail: robin.c@cochinshipyard.in  
Phone: 0484 2501263



पंजीकृत कार्यालय : प्रशासनिक भवन, पी.ओ.बैग सं 1653, पेरुमानूर पी. ओ., कोच्ची - 682 015  
Registered Office : Administrative Building, P.O. Bag No. 1653, Perumanoor P.O., Kochi - 682 015  
फोन / Phone : +91(484) 2361181 / 2501200 फाक्स / Fax : +91 (484) 2370897 / 2383902  
वेबसाइट / Website : www.cochinshipyard.com, सीआईएन / CIN: L63032KL1972GOI002414

## **ELIGIBILITY CRITERIA**

### **a) General**

- The firm should have successfully completed minimum 5 projects of Supply and Installation of PUF sandwich panels in Fish preservation industry/ Dairy industry/ Marine application in the last 3 years from the date of floating of this tender

### **b) Financial criteria**

- The bidder shall have average annual turnover equivalent to 30 lakhs (INR) for the last three financial years ending March 2021.
- The Applicant (firm) who had applied for Corporate Debt Restructuring (CDR) in three years viz., 2018-2019, 2019- 2020, 2020-2021 and till the due date for submission of the bid is not eligible to participate in this tender.
- The bidder shall furnish solvency certificate issued by a nationalized / scheduled bank for not less than Rs. 30 lakhs (INR). The applicant shall submit the solvency certificate, not older than 3 (three) months prior to last date of submission of this tender.

*(For more details, please see Clause No.9 of Purchase technical specification attached at Annexure-2)*

Rev-0

This document contains 9 pages



**COCHIN SHIPYARD LIMITED**  
COCHIN – 682 015

YARD NO		TFV01 - TFV30		<b>TUNA LONGLINER CUM GILL NETTER FISHING VESSEL</b>													
OWNER				<b>PURCHASE TECHNICAL SPECIFICATION FOR SUPPLY AND INSTALATION OF SANDWICH PUF PANEL FOR THE FISH HOLD</b>													
APPROVED		Manoj S															
CHECKED		Naishan K G															
PREPARED		Phil D'souza															
DATE		02.05.2021		SCALE: - NA				Doc. No. N40010238500010									
ISSUED TO	DEP																
	NO.																Page 1/9

	<b>COCHIN SHIPYARD LTD</b> (A GOVERNMENT OF INDIA ENTERPRISE) <b>COCHIN -682 015</b> <b>INDIA</b>	Fishing Vessels		Page No. 2/9			
		Yard No.	Spec.No.	Rev.No.	Prep.	Chkd.	Appvd.
		FV01 – FV30	N40010238500010		PHIL	NKG	MANOJ S

**PURCHASE TECHNICAL SPECIFICATION FOR SUPPLY AND INSTALLATION OF SANDWICH PUF PANEL FOR THE FISH HOLD –FISHING VESSELS**

**1. BRIEF DESCRIPTION OF SCOPE**

Cochin Shipyard hereinafter called the yard is carrying out construction of Tuna Longliner cum Gill Netter Fishing vessels (20 confirmed + 10 optional) intended for the deep-sea fishing. The vessel will have adequate stability and good maneuvering capabilities under normal sea going conditions and shall have a maximum speed of 8 knots.

The vessel is having a fish hold of approximate capacity 70 m<sup>3</sup> covered with insulated PUF sandwich panels with wooden partitions inside for proper stowage of ice and fish. The insulated PUF sandwich panel shall be capable to maintain a temperature of -4°C and strength requirement of storing ice for proper storage of the fish as well. As a part of this tender, yard intends to offload the supply and installation of the insulated PUF sandwich panel on a turnkey basis through a capable firm hereinafter called the subcontractor.

The subcontractor should take proper estimation of all material required for supply and installation of sandwich PUF panels for fish hold based on the technical requirements and reference drawing provided at Annexure 1. All materials, workman ship and quality of material for the construction shall be in accordance with good shipbuilding practice.

**2. PARTICULARS OF THE VESSEL**

Length overall (approx.)	22.70 m
Breadth, moulded (approx.)	6.40 m
Depth moulded (approx.)	3.00 m
Draught (max.)	1.80 m
Compliment	12 Persons
Speed	8 Knots
Engine Power	230 hp @ 2200 rpm

**3. DESIGN CONDITIONS**

The following ambient conditions shall be considered for the design and material for construction.

- Maximum outside air temperature of 35°C with 90% relative humidity
- Air temperature of 45°C in the Engine room
- Maximum sea water temperature of 32°C
- Atmospheric pressure of 760 mm Hg
- Temperature holding capacity of Fish hold -4°C
- Capacity of Fish hold 70 m<sup>3</sup>

 <p><b>COCHIN SHIPYARD LTD</b> (A GOVERNMENT OF INDIA ENTERPRISE) <b>COCHIN -682 015</b> <b>INDIA</b></p>	Fishing Vessels		Page No. 3/9			
	Yard No.	Spec.No.	Rev.No.	Prep.	Chkd.	Appvd.
	FV01 – FV30	N40010238500010		PHIL	NKG	MANOJ S

#### 4. SCOPE AND TECHNICAL PARTICULARS

Insulation	PUF sandwich Panel
Density requirement of the PUF	40 ± 2 Kg/m <sup>3</sup>
Thickness of Outer panel	Not less than 100mm/capacity to maintain a temperature of -4°C
Insulation covering- external and internal for wall & ceiling	SS304 Minimum thickness 0.5 mm sheet on both sides
Insulation covering- external and internal for Bottom	Top: Not less than 3 mm Aluminum chequered plate Bottom : 0.5mm SS 304 sheet
Material for fish hold inside partitions	Good quality Anjili wooden planks with soft part fully removed having adequate length as shown in the attached drawing having finished width of each plank 1 feet (4 Nos. Plank on each partition) and thickness 25 mm approx.
<p><b><i>Note: This shall be quoted separately as an option. It may please be note that the same shall not considered for the determination of L1 bidder.</i></b></p>	

1. The PUF panel shall be of cam lock type and shall be CFC/HCFC free and the panels shall have low weight with high load bearing capacity.
2. The fish hold shall be insulated with excellent and durable thermal insulation which shall be water & vapor barrier.
3. The PUF panel for insulation shall have adequate fire resistance and free of thermal bridges.
4. The Fish hold drawing should be prepared by the subcontractor including all the construction details with the reference provided at Annexure 1 and to be submitted to yard for approval.
5. The entire bottom, wall, ceiling and flashings as shown in the attached preliminary Fish hold sketch shall be considered in the scope of supply. All the necessary fittings shall also be included in vendor scope of supply. The fitment shall be turnkey in nature. The attached sketch is for guidance only.
6. Sufficient deck opening of around 2.5m x 1.5m shall be provided by the yard for the installation of the PUF sandwich panel. The subcontractor may indicate the necessary opening size for installation of these panels. The subcontractor has to install the panels as per launching schedule of the vessel.
7. All the in-way jobs associated with the installation of the PUF sandwich panels shall be included in the scope of supply. Four nos. of light fittings shall be fitted in the fish hold. Supply of light fittings and required cables shall be in the yards scope. However, penetrations, sealing compounds/sealants shall be included in the subcontractor's scope of supply.
8. All fasteners, fixing flat bars/angles to be included in the scope of supply and shall be of material SS 304.



**COCHIN SHIPYARD  
LTD**  
(A GOVERNMENT OF INDIA  
ENTERPRISE)  
**COCHIN -682 015  
INDIA**

Fishing Vessels

Page No. 4/9

Yard No.

Spec.No.

Rev.No.

Prep.

Chkd.

Appvd.

FV01 – FV30

N40010238500010

PHIL

NKG

MANOJ S

9. The subcontractor shall make the provision for Pipe of adequate size for draining of fish hold to drainage tank placed below the hold and routing the electrical cables for lighting. Openings for the slurry ice making machine piping connections, supports and evaporator coil supports shall be included in the supplier's scope.
10. The unit price quoted per meter square (m<sup>2</sup>) for the supply and installation of each sandwich panels shall be indicated in the offer separately.
11. Sealing compounds for all the penetration in fish hold shall be included in the subcontractor's scope of supply
12. The subcontractor to ensure proper insulation in way of hatch coaming and hatch cover.
13. The installation and commissioning timelines shall be shared to the subcontractor 7 days in advance by the yard and subcontractor shall depute their competent personnel and complete the same accordingly.
14. Employees of the subcontractor shall work in close co-ordination with yard personnel, yard subcontractors with a conciliatory approach and team spirit to complete the project as per schedule.
15. The transportation facilities like forklift and cranes etc. inside the yard for the sandwich panel shall be provided by yard subject to availability.
16. The supply and installation of wooden partitions and supporting structure (Square tube, C channel and other consumable) as indicated in Annexure 1 shall be quoted separately as an option. This shall not be considered for determination of L1 bidder.

#### **5. TESTING AND INSPECTION**

**a). Shop Inspections:** Required inspections/testing to prove the compliance of structural/operational requirements shall be considered in accordance with the manufacturers standard and the same shall be indicated in the offer.

**b). Onboard Test & trial:** To verify the functionality and other requirements if any, the firm has to conduct onboard tests as per the manufacture standard. Any defect during this trial/tests shall be rectified/replaced by the subcontractor without any financial implications to the yard.

**c). Material Certification:** As applicable, shall also be submitted by the supplier.

#### **6. GUARANTEE**

As per the commercial terms and conditions of the tender enquiry.

 <p style="text-align: center;"><b>COCHIN SHIPYARD LTD</b> (A GOVERNMENT OF INDIA ENTERPRISE) <b>COCHIN –682 015</b> <b>INDIA</b></p>	Fishing Vessels		Page No. 5/9			
	Yard No.	Spec.No.	Rev.No.	Prep.	Chkd.	Appvd.
	FV01 – FV30	N40010238500010		PHIL	NKG	MANOJ S

## 7. SUPPLY OF DOCUMENTS

All documents shall be in English and metric system. The following documents shall be submitted as listed below.

### a) Documents to be submitted along with the offer

- 1) Dimensional drawings/ General arrangement drawing with CG marked and connection points(x, y, z co-ordinates) indicated.
- 2) Material of panel internal and external and for walls and ceiling.
- 3) Installation procedure.
- 4) All relevant technical details including unit weight of items and the temperature at which the fish hold can be maintained.
- 5) Compliance Matrix and Deviation list.

### b) Documents within fifteen days after placement of Order/LOI (1 sets hard copies and two soft copy (drawings in AutoCAD format))

- 1) Detailed Bill of Material.
- 2) Installation procedure.
- 3) Details of shop tests and inspection.

### c) Documents/Certificates to be supplied with each equipment (3 sets hard copy and two soft copy unless otherwise mentioned)

- 1) Guarantee certificate as detailed above.
- 2) Test certificate / inspection results of various tests & trials conducted.
- 3) Manufacturer's certificate of conformity

## 8. GENERAL REMARKS

- All materials, equipment, and components for use on-board shall be new, unexploited, and suitable for marine application.
- All outfitting shall be selected, and all construction shall be carried out, emphasizing easy access for inspection, cleaning, maintenance and repair.
- The quality of the construction, selection of outfitting materials/fittings and workmanship shall be in accordance with good shipbuilding practice.
- Entry passes for employees of the subcontractor shall be arranged by the yard. The details of employees and the required details/documents shall be forwarded to yard well in advance.
- Materials/ tools and equipment return passes based on entry declaration of the subcontractor. Subcontractor shall take adequate care in obtaining entry declaration form while bringing in materials, tools, etc inside yard. Yard will not be liable to issue



**COCHIN SHIPYARD  
LTD**  
(A GOVERNMENT OF INDIA  
ENTERPRISE)  
**COCHIN -682 015  
INDIA**

Fishing Vessels

Page No. 6/9

Yard No.

Spec.No.

Rev.No.

Prep.

Chkd.

Appvd.

FV01 – FV30

N40010238500010

PHIL

NKG

MANOJ S

return passes for items brought inside the yard by the supplier without a duly authorized material declaration form as such items will be treated as yard property.

- Permission for round the clock working shall be permitted subject to the yard rules and regulations.

## 9. ELIGIBILITY CRITERIA

### a. General

- The firm should have successfully completed minimum 5 projects of Supply and Installation of PUF sandwich panels in Fish preservation industry/Dairy industry/ Marine application in the last 3 years from the date of floating of this tender. (see note i and ii)

### b. Financial criteria

- The bidder shall have average annual turnover equivalent to 30 lakhs (INR) for the last three financial years ending March 2021.
- The Applicant (firm) who had applied for Corporate Debt Restructuring (CDR) in three years viz., 2018-2019, 2019- 2020, 2020-2021 and till the due date for submission of the bid is not eligible to participate in this tender.
- The bidder shall furnish solvency certificate issued by a nationalized / scheduled bank for not less than Rs. 30 lakhs (INR). The applicant shall submit the solvency certificate, not older than 3 (three) months prior to last date of submission of this tender. (see Annexure 2)

### **Note:**

- i. The bidder shall submit the details of clients and self-attested copy of Purchase Order (PO) for evaluation.
- ii. CSL reserves the right to obtain clarifications or confirmation directly from the bidder's clients. CSL may visit the installations carried out by the bidder in order to have firsthand information regarding the performance and after sales support rendered by the firm. The Bidder shall co-ordinate for obtaining approval / consent for the above-mentioned visit whereas travelling and all other expenses for the same shall be borne by CSL. Final acceptance of the offer is subject to the receipt of satisfactory feedback from the clients as mentioned above.



	<b>COCHIN SHIPYARD LTD</b> (A GOVERNMENT OF INDIA ENTERPRISE) <b>COCHIN -682 015</b> <b>INDIA</b>	Fishing Vessels		Page No. 7/9			
		Yard No.	Spec.No.	Rev.No.	Prep.	Chkd.	Appvd.
		FV01 – FV30	N40010238500010		PHIL	NKG	MANOJ S

**10. COMPLIANCE MATRIX**

A compliance matrix in the following format shall be submitted by the supplier along with the offer. Deviations from the Technical specification shall be specifically indicated.

VENDOR NAME AND ADDRESS:				SPEC.NO/OFFER NO:	
				PAGE NO:	
ITEM DESCRIPTION :				SHIP: TFV 01 - TFV 30	
Sl.No.	SPEC.CLAUSE NO.	REQUIREMENT	STATUS (A/N/C*)	DEVIATION/REASON	FOR CSL COMMENT

A-Acceptable, N-Not Acceptable, C-Conditional acceptance.

**11. PLACE AND DATE OF DELIVERY**

As per the commercial terms and conditions of this tender enquiry

**12. LIST OF ANNEXURES INCLUDED**

1. Annexure 1 - Preliminary Fish hold sketch
2. Annexure 2 - Solvency certificate format

**NOTE:** *Notwithstanding any omission in this specification, all items/features required as per safe working and good ship building practice shall be included in the offer by the bidder.*

# ANNEXURE - I

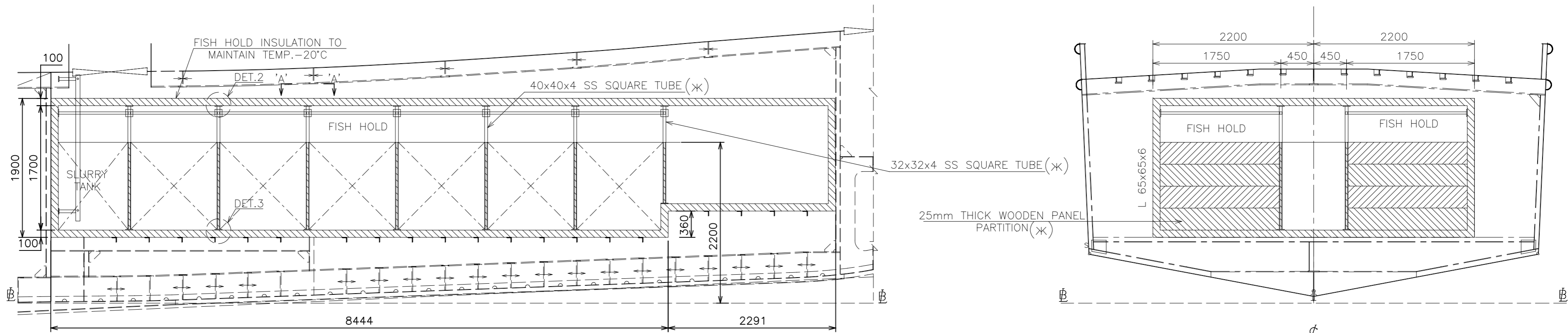

PROFILE

FR 20

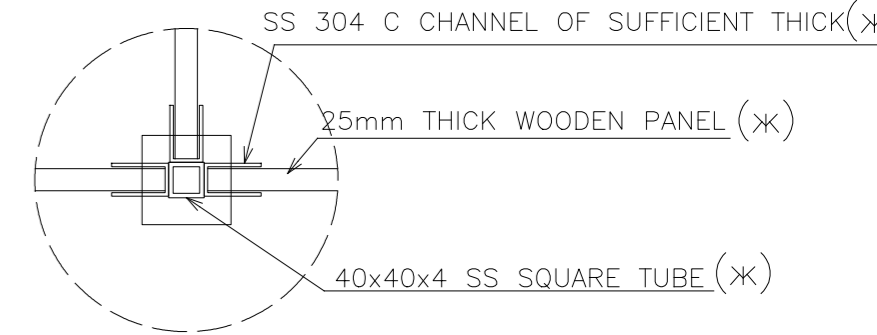
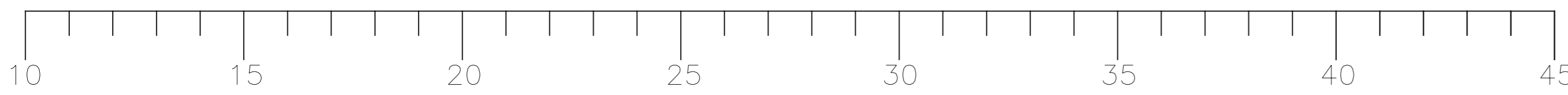

DET.1

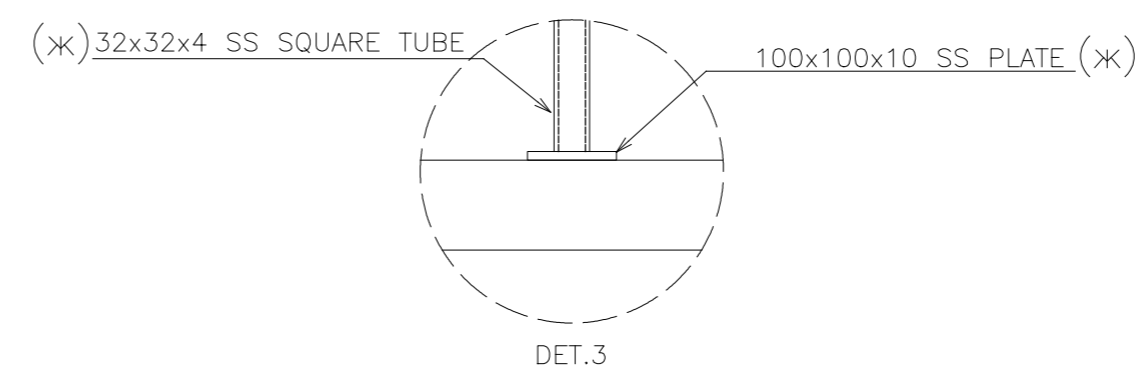

DET.3

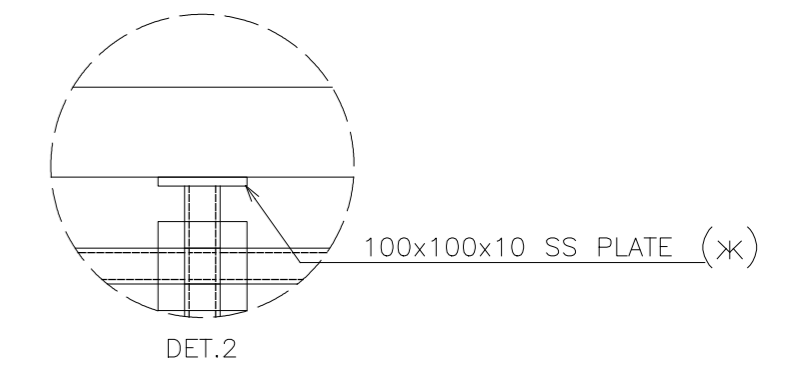

DET.2

FIXED PUF SANDWICH PANEL FISH HOLD (100 mm Thick-Minimum)  
 FIXED WOODEN PANEL (25 mm Thick-Minimum)  
 REMOVABLE WOODEN PANEL (25 mm Thick-Minimum)

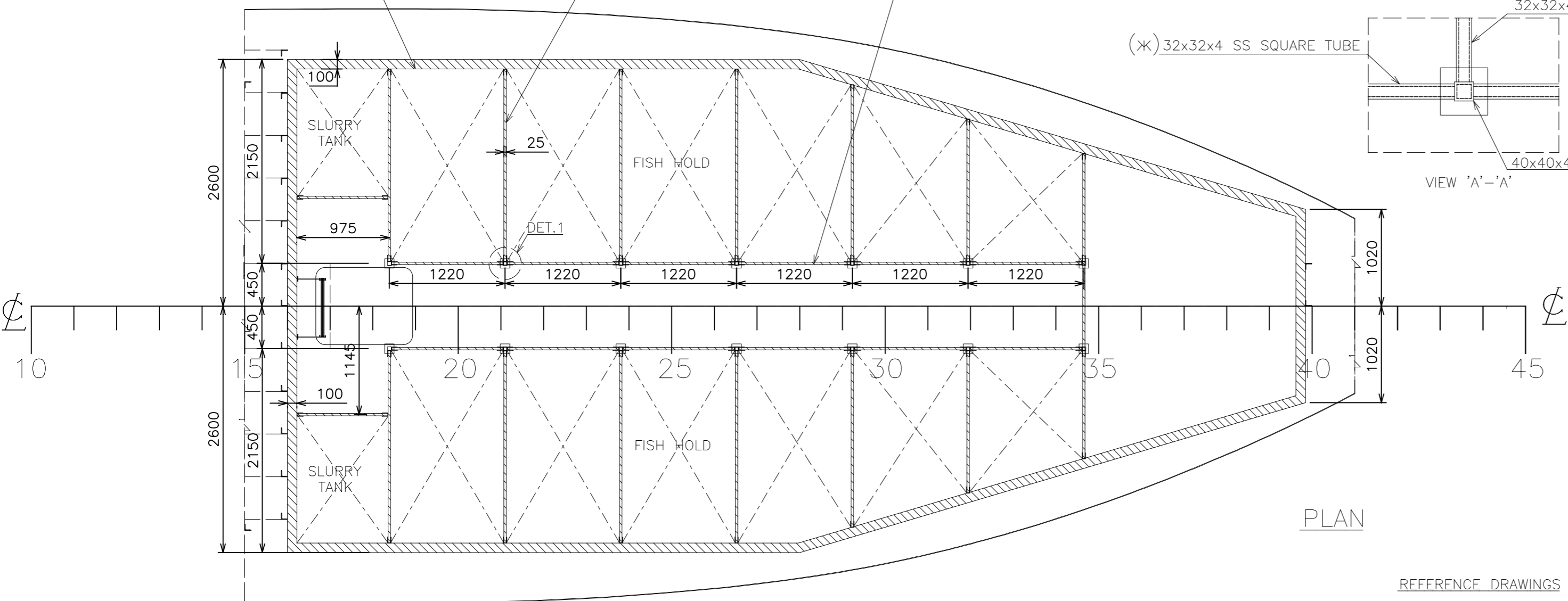

PLAN

### MAIN PARTICULARS :

- LENGTH O.A..... abt 22.70 M.
- LENGTH B.P..... abt 20.25 M.
- BREADTH (MLD)..... abt 6.40 M.
- DEPTH (MIDSHIP)..... abt 3.00 M.
- DRAFT (MAX.)..... abt 1.80 M.
- FRAME SPACING..... 450 MM
- SPEED..... 8 KNOTS.
- REFRIGERATED FISH HOLD... abt 72 Cu m.

Note :-  
 (✳) - SHALL BE QUOTED SEPARATELY AS AN OPTION.

- REFERENCE DRAWINGS
- P121-101-001 General Arrangement
  - P121-200-002 Profile and Deck Plan
  - P121-200-003 Midship Section

Rev.0	05.Mar.2021	Preliminary	Amal.s	Abhishek	Binoy
No.	Date	Description	Drawn	Checked	Approved
CUSTOMER			TUNA LONGLINER CUM GILL NETTER FISHING VESSEL		
Yard Nos.: TBD			<b>FISH HOLD CONCEPT SKETCH</b>		
COCHIN SHIPYARD LIMITED P.O. Bag 1653, COCHIN-682015, INDIA			1:60	A3	BD-P168 P168-490-002 08/09
			Scale	Format	Project No. Dwg. no. Sheet No.
ACCORDING TO INTERNATIONAL LAWS, THIS DRAWING IS THE PROPERTY OF COCHIN SHIPYARD LTD. THE DRAWING CAN NOT BE MADE PUBLIC COPIED OR OTHERWISE USED, WITHOUT WRITTEN CONSENT.					

## ANNEXURE – II

### SOLVENCY CERTIFICATE

Certified that to the best of our knowledge and information (Insert name of applicant)....., a customer of our bank is respectable and can be treated as capable for executing the work up to a limit of Rs. ....(Rs.....).

It is clarified that this certificate is issued without any guarantee or responsibility on the bank or any of the officers.

Signature

Manager,

Bank

Note: This certificate may be issued on the letter head of the bank and addressed to the General Manager (Design), Cochin Shipyard Ltd

**GENERAL TERMS AND CONDITIONS OF ENQUIRY (Annexure-3)**

SL NO	Description	Compliance by Supplier (YES/NO) In case of non compliance, please provide remarks.
1	Tenderers are to carefully go through the terms and conditions and the technical specification of the items for which offers are called for. Tenderers have to adhere to above and supply full technical scope of items along with compliance of commercial conditions. CSL have full right upon deviations, if any, including rejecting the partial scope/ complied offers.	
2	Offers are to be furnished in duplicate and should be free from overwriting. Corrections and additions, if any, must be attested. <del>In the case of E tender offers shall be submitted only through CSL E procurement portal.</del> Incomplete/ ambiguous/ conditional offers are likely to be rejected.	
3	Technical checklist, if applicable and current general terms & conditions of enquiry duly filled and signed and technical specifications of items offered (refer clause5), should be submitted alongwith part-1 techno-commercial bid in the case of two-bid tenders and along with the bid documents in the case of single bid. Non receipt of the document may lead to rejection of offers. <del>In the case of E tender filling up of GTC check list in the portal itself is sufficient.</del>	
4	Spare/Tool requirements to be confirmed, if applicable i) Standard Spares and tools shall be supplied. This shall include electrical spares and Installation and commissioning spares. ii) The same shall be included in offered costs and shall be a part of L1 evaluation.	
	Following Certificates is to be submitted for the item in the event of an order: a) Valid type approval certificate from the classification society for navigation & signal light (EC Type examination certificate) b) Test certificate and inspection results c) Complete details of light fittings supplied d) Instruction/ Operation and Maintenance Manuals e) Any other certificate required as per International Regulations in force	
5	<b>SPECIFICATIONS:-</b> a) Manufacturer's name, their trade mark and brand, if any, should invariably be mentioned and illustrative leaflets giving technical particulars (technical details of items offered including technical literature) etc., should be attached to the offer.	
	b) Materials offered shall conform to CSL specifications and drawings.	
	c) <del>Samples are to be supplied free of cost in the event of requirement by CSL.</del> The detailed working drawing, if called for, is also to be furnished for approval before commencement of manufacture.	
6	Packing materials should be eco friendly.	
7	Supplier should follow the statutory requirements of product offered.	
8	Products supplied shall be non toxic and harmless to health. In case of toxic materials, Materials Safety Data Sheet may be furnished along with the material.	
9	COMMISSIONING:- Service engineer assistance for commissioning is to be included in scope and costs.	
	b) Cost considered to include travel tickets, lodging and local transport costs.	

	c) Additional manday rates to be indicated separately (all inclusive of cost for lodging and local transport etc.) for extension beyond agreed mandays.	
	d) Whether the applicable taxes in India shall be borne by CSL/Supplier (In the case of foreign vendors)	
	e) Income tax liability of non resident service engineer based on his period of stay in India shall not be borne by CSL	
	f). The non resident vendor/service provider shall provide such documents that are necessitated by the Indian income tax laws so as to enable CSL to comply with the provisions of Indian statute and for payments of income tax in India. Following documents shall be sought by CSL in this regard (i) Certificate under 10 (F) (ii) Tax residency certificate (iii) The certification regarding the existence/non existence of business connection or permanent establishment in India. (The above is only an indicative list)	
10	Taxes and duties, if any, payable extra are to be indicated in the <del>price part for single bid and in techno commercial part and price part (in the case of 2 bid tender).</del>	
11	<b>MSEs, Startups and Make in India</b> a) Local Suppliers (Make In India), MSME firms and Startups will be eligible for various Relaxations in pre-qualification criteria and other Benefits as per the orders promulgated by Government of India. Bidders are advised to refer the details of various Benefits and Relaxation in pre-qualification criteria as published at CSL website (www.cochinshipyard.com) under the Tenders tab for further reference.	
12	Delivery time required for supplies should be indicated in the offer (including time frame for drawing preparation, class approvals, manufacture etc.). Please note, required date of items at CSL is as per page 1 of tender enquiry.	
13	<b><u>SHIPMENT</u></b> a. Supplier shall intimate CSL the readiness of the Equipment/ Machinery/ Components and Parts prior to fourteen days of shipment. b. A minimum 14 days free detention period is to be granted for clearance of the goods at Cochin seaport, as applicable for full containers.	
14	<b><u>PAYMENT TERMS:</u></b> a) <u>For Material Supply with commissioning</u> :- CSL payment term is 90% along with 100% applicable taxes within 30 days from the date of receipt and acceptance of materials at CSL stores after inspection and balance 10% on satisfactory completion of commissioning certified by CSL. b) <u>For Installation &amp; Commissioning</u> : - 100% payment within 30 days after completion of installation & commissioning. Work completion certificate issued by CSL outfit dept. duly signed to be furnished for releasing payment.	
	<del>b. For general items -CSL payment term is 100% within 30 days of receipt and acceptance of materials at CSL stores after inspection.</del>	

	<p>c) Payment mode shall be Electronic Clearing System (ECS)/cheque /NEFT/ /LC/ CAD/ TT-as mutually agreed in line with above standard payment terms. Variations from standard terms, if any, shall be appropriately loaded for tender comparison purposes for arriving the lowest bid. Bank charges (including LC charges, if any) inside India will be to CSL account and outside India to supplier's account (In the case of import shipments). The charges for LC amendment, if any, shall be borne by the parties by whom the same is attributed/ necessitated.</p>	
	<p>d) Normally advance payments are not encouraged. In case, if advance payment is sought, the same can be considered for a maximum of 10% order value only. Interest at the base rate of SBI { applicable on the date of price bid opening } + 1% for the amount of advance will be charged. In addition, Bank guarantee for equivalent amount of advance to cover the period till advance payment is adjusted to be furnished. (ie till completion of supplies or for a period as specifically agreed + 90 days). In case interest as above is not agreeable to be paid, the same will be loaded on your quoted basic prices, for tender comparison purposes for arriving the lowest bid</p>	
	<p>e) For deviation in Payments terms from CSL standard terms, if any, aforesaid interest will be loaded on quoted item prices, for tender comparison purposes for arriving lowest bid.</p>	
	<p>f) Part payment shall be considered only if specifically agreed against partial supplies.</p>	
15	<p><b><u>Security Deposit/ Warrantee Bank Guarantee:</u></b></p> <p>a.i The successful bidder shall remit a security deposit of 3% of the total order value (excluding taxes, duties) in the form of demand draft drawn in favour of Cochin Shipyard Ltd towards the satisfactory performance of the contract, if an order is placed on them. Alternatively, a Bank Guarantee equivalent to above % of the total order value (excluding taxes, duties) as per CSL format from an International Bank as per approved list of banks available in CSL website (for overseas supplier) &amp; Scheduled Indian bank for Indian supplier is to be submitted, if an order is placed towards satisfactory performance of the contract.</p> <p>a.ii)The supplier shall also agree for 3% of total order value (excluding taxes and duties) as Bank guarantee towards the Guarantee clause</p> <p>a.iii) The Bank Guarantee/ DD as above should be initially valid till 90 days after completion of supplies in terms of SD and later revalidated (within the validity of initial BG) to cover the guarantee period mutually agreed plus 90 days. However in the case of items where WBG is not applicable (as in 15.a.ii), the SD shall be valid for item delivery at yard plus 90 days. Fixed Deposit Receipt (for equivalent amount of Security Deposit/ WBG required as per tender) in lieu of bank guarantee is also acceptable. Fixed Deposit Receipt shall be in the name of supplier with lien marked in favour of Cochin Shipyard Limited, Kochi.</p> <p>a.iv)The above SD/ WBG is required or applicable only when the total order value (excluding taxes and duties) is Rs.20lakhs and above (or equivalent foreign currency). In case supplier have quoted Rs.20 lakhs and above in tender and indicated that BG as not applicable in the check list, the clause 15b shall be considered for further process.</p>	
	<p>b) If the bidder is not agreeable to submission of SD/ warrantee bank guarantee as per CSL general terms and conditions of enquiry, CSL reserves the right to reject the offer at our discretion or 3% of total order value (excluding taxes and duties) will be added to the quoted price for tender comparison/ evaluation purpose on case to case basis for arriving the lowest bid.</p> <p>However in cases where total quoted value is less than 20 lakhs,(ie split order etc) and the order value of entire tendered items is more than Rs 20.0 lakhs , the aforesaid loading will be applied on individual items in following cases.</p> <ul style="list-style-type: none"> <li>• The bidder has not quoted for entire tendered quantity</li> <li>• CSL has technically / commercially rejected a few items in the tender</li> </ul>	
	<p>c) SD to be submitted within 2 weeks of receipt of order from yard.</p>	

	d) Format of bank guarantee along with enquiry to be agreed, in general	
	e) Mode of receipt of bank guarantee is strictly through SWIFT mode from supplier bank to CSL designated bank (for overseas bidders)	
	If the supplier fails to supply the items ordered in good quality as per contract specification and fails to deliver within the delivery date or violate any of the terms and conditions of the purchase order, CSL shall have the following rights.	
16	a. To cancel the order partially or full with 15 days notice and to forfeit the security deposit, if any.	
	b. To impose tender holiday for the vendor for an appropriate period as decided by CSL	
	c. <b>Risk Purchase:-</b> To initiate alternate procurement action at the risk and cost of the supplier. This Risk Purchase clause is applicable only in the case of total order/ contract value (excluding taxes and duties) is Rs.20 lakhs and above (or equivalent foreign currency). Cases of value less than 20 lakhs will be addressed by serving appropriate caution/ warning notice to the firm.	
17	<b><u>Liquidated Damage:</u></b> In case of delay in supply of ordered materials beyond the stipulated delivery period, which is not attributable to CSL, supplier is to pay Liquidated Damages (and not by way of penalty) a sum equivalent to ½% (half percent) per week or part of the week of the total basic price in case of Machinery/Equipment and of basic price of materials delayed in all other cases, subject to a maximum of 10% of the total basic price of undelivered material/10% of total basic price of machinery/equipment (Total basic price is the order value excluding freight, taxes, other charges etc.). Further, GST will be applicable upon LD and the same also will be deducted along with LD. However LD applicability is without prejudice to CSL right to terminate contract for delayed delivery or other actions as per clause 16.	
18	<b><u>Guarantee</u></b> a) The Items supplied shall be guaranteed for rated performance and against damage or failure due to faulty design, defective materials and bad workmanship for a period from delivery of items until 12 months from the date of delivery of the ship to Owners OR 24 months from delivery of items to Yard, whichever is earlier. Should such damage/ failure occurs within the Guarantee period, the Supplier should immediately rectify the failure by repair/ replacement of any such part found to be under performing/ defective, at his own expenses.	
	b) Further to equipment guarantee, replaced/ repaired items shall be guaranteed for 12 months from date of repair/ replacement.	
19	<b><u>Jurisdiction:</u></b> All questions, disputes or difference arising under, out of, or in connection with contracts shall be subject to the exclusive jurisdiction of the Courts at Cochin, India. Alternate dispute resolution mechanism can also be considered.	
20	<b><u>Force Majeure condition:</u></b> Should failure in performance of the contract or part thereof arise from war insurrection, restraint imposed by Government, Act of Legislature or other Statutory Authority or illegal strike, riot, legal lock-out, flood, fire, explosion, act of God or any inevitable or unforeseen event beyond human control which may be construed as reasonable ground for an extension of time, CSL may allow such additional time as is mutually agreed, to be justified by the circumstances of the case. The occurrence/cessation of force majeure situation is to be informed with documentary evidence within 15 days from the date of occurrence/ cessation.	
21	<b><u>Indian Agent:</u></b> a) Cochin Shipyard Ltd, prefers to deal directly with the supplier. However, if the supplier appoints an Indian Agent to deal with Cochin Shipyard Ltd., the Agency commission payable by the supplier to such an agency shall be intimated.	

	b) If manufacturers effect the supply through Agents only, authorization in writing from manufacturers in favour of the Agent for supply to CSL shall be furnished.	
	c) In case where an Agent participates a tender on behalf of a Foreign manufacturer Indian agent should submit specific authorization from the authorized person of foreign manufacturer.	
	d) In a tender, either the Indian agent on behalf of the Principal/ OEM or Principal/OEM itself can bid but both cannot bid simultaneously for the same item/ product in the same tender. If an agent submits bid on behalf of principal/OEM, the same agent shall not submit a bid on behalf of another principal/OEM in the same tender for the same item/product. Indian agents cannot represent more than one firm or quote on their behalf for any particular tender.	
	e) Clarifications, either technical or commercial, should be submitted to points specially asked for only. The opportunity so given should not be used for correcting/ changing/ amending the data/ conditions already submitted with the tender	
22	<b>PRICING:</b> a. Bidders should quote prices for delivery of materials at Tebma Shipyard Stores, Malpe Harbour Complex, Malpe, Udupi, Karnataka – 576 108. Insurance shall be to TSL scope. <del>In the case of E tender C&amp;F price shall be quoted and the freight charges shall be indicated separately under header conditions as per the provision in the CSL e-tender portal.</del>	
	b. Exchange rate variation will not be applicable and the prices shall be fixed for an order within validity period in the case of indigenous orders.	
	c. Offer to be submitted in INR currency. Indian Firms shall quote in INR only.	
	d. Comparison of prices will be in INR only. All foreign currencies will be converted to INR for comparison and Exchange rate as on date of price bid opening shall be considered for arriving lowest bid	
	e. Prices should be valid for acceptance for a period of four months from the date of tender opening.	
	f. No enhancement of rate for whatsoever cause will be allowed once the offer is accepted and an order is placed. Withdrawal of the quotation after it is accepted or failure to make the supply within the stipulated delivery period, will entail cancellation of the order and forfeiture of Earnest Money Deposit/Security deposit, if any and/or risk purchase, without prejudice to other penal actions, including tender holiday after serving show cause notices, as deemed fit.	
	g. Conditional discounts, if any, will not be reckoned for tender evaluation/ comparison purpose. However, if the bidder becomes L1 at original offer, conditional discount shall also be considered.	
	h. Unpriced bid (price bid without price) duly signed is to be submitted alongwith techno-commercial offer in the price format, provided. Price should be quoted separately for each item shown in the format. In the event price bid is different from the unpriced format already submitted, yard reserves the right to reject the offer at our discretion without any further discussions. Details of optional items, if any, should be indicated under separate heading in the Techno commercial bid and the respective price details should also be given in the price bid. Combining of figures against more than one item and ambiguous clauses will lead to rejection of the bid.	
	i. If, in the price structure quoted for the required material/ item, there is discrepancy between the unit price and the total price (which is obtained by multiplying the unit price by the quantity), the unit price shall prevail and the total price corrected accordingly. If there is an error in a total corresponding to the addition or subtraction of subtotals, the subtotals shall prevail and the total shall be corrected. If there is a discrepancy between words and figures, amount in words of respective figures shall prevail. If the bidder does not agree to the observation of the CSL, the tender is liable to be rejected and the same shall be intimated.	



	j. After submission of quotation/price offer no unsolicited correspondence will be entertained.	
	k. Cochin Shipyard Limited does not bind itself to accept the lowest or any tender but reserves to itself the right to reject any or all or a part of any tender at its discretion.	
	l. CSL reserves the right to place order to the techno-commercially qualified lowest bidder in full or individual items to the respective lowest bidders in the tender.( <del>except in cases where basis of L1 arrival is declared specifically in enquiry</del> ). Also please refer loading applicable for split order of value less than 20 lakhs (Clause 15 b)	
	m. In the case of part quantity order, the quoted P&F charges, FOB charges, freight charges, etc. applicable for the entire quantity as per enquiry shall be apportioned and allocated.	
	n. Design, Support & Commissioning Engineer shall be as per Clause No.9 of Purchase Technical Specification	
	o. Supplier must quote per man day rate for further extension of installation and commissioning period	
23	<b><u>Integrity Pact:</u></b> As per Government of India (Central Vigilance Department), CSL and the SUPPLIER have to sign an Integrity Pact for the high value contracts, for ensuring transparency, equity and competitiveness in public procurement. The Tenderer has to sign Pre-Contract Integrity Pact as per format enclosed and to submit along with your offer. The above is applicable when the total basic price is above Rs. 100.0 lakhs. (present limit)	
24	<b><u>Grievance Redressal Committee:</u></b> As an alternate dispute redressal or reconciliation mechanism (other than arbitration clause), Cochin Shipyard has constituted Grievance Redressal Committee. Currently following executives of the committee may be contacted for the settlement of disputes, if any, arising out of all contracts. a) Mr. Harikrishnan S, GM (Materials) b) Mr. Subramanian K K, Assistant General Manager (HR) c) Mr. Shibu John, Deputy General Manager (Finance)	
25	<b>SUB CONTRACTING AND ASSIGNMENT</b> Supplier shall not contract with any subcontractor and/or vendor without the prior written consent of CSL. Such consent shall not relieve the Supplier from any of his responsibilities and liabilities under the Purchase Order. In addition, Supplier shall ensure that the terms and conditions of any such contract shall comply with and correspond to the terms and conditions of the Purchase Order.	
26	<b><u>General:</u></b> a. Prior to price bid opening, CSL is at liberty to take the credit rating of bidders at our cost on case to case basis, and to include the same during the evaluation of the tender. b. Deviations, if any in the techno-commercial offer from that of the tender enquiry in any form should be clearly furnished in a separate document titled as “List of Deviations”, failing which it will be presumed that all the terms and conditions are acceptable. c. The techno-commercial part alone will be opened initially on the due date of tender. The price part will be opened only after evaluation of the Techno commercial part. Date of opening of the price part will be intimated to those firms whose Techno- commercial bids would be acceptable after the evaluation. Suppliers are allowed to depute their authorized representative to be present at the time of opening of Price Bid of their tender only. In case of E-Tender, suppliers shall not depute their representative to CSL. However techno-commercially qualified supplier can view the price details in CSL E-procurement portal after opening the price-bid	

27	<p><b>P.O:-</b> a. In the event supplier's offer leads to an agreement to effect supplies, a formal purchase order shall be issued by CSL on the basis of agreed terms and conditions of tender.</p>	
	<p>b. Upon placement of order (by post or mail) the supplier shall submit the acknowledgement (ie: signed and stamped original/ scanned soft copy by mail) as a token of acceptance of order within 15 days. In case CSL doesn't receive the above, it will be deemed as accepted.</p>	
28	<p><b>SUPPLY:</b> - a) CSL reserve the right to inspect the goods after receipt at CSL store / prior to dispatch (by CSL or CSL authorized agency at yard cost). Short supply / Mismatch / Replacement of Defective items / those not meeting agreed / contractual specification/ Items failing during commissioning shall be sent on air freight/ DDP basis courier freight prepaid/delivered at CSL store. The customs clearance charges of above shall be to supplier account.</p>	
	<p>b) Replacements during guarantee period to be sent on Duty and all taxes paid basis to location as required by yard/vessel owner with all expenses to supplier account.</p>	
	<p>c) Defective items, if any, after receipt shall be sent back on cost, carriage, handling and insurance prepaid basis including re-export (wherever desired by supplier) to be arranged by supplier. Defective items shall be returned after receipt of replacement item. Supplier, shall replace all/ part of items as applicable, in case of rejection, within 4 weeks of reporting the defect, without any additional cost to CSL. In case the defective materials are not taken back within the said period, CSL reserves the right to dispose the same without further intimation.</p>	
	<p>d) The supplier shall compensate CSL for loss on account of shortage in quantity and number of pieces received than that indicated in the bill of lading provided the CSL's claim is rejected by the insurance due to any fault of supplier. Such claims, if any, shall be supported by recognized surveyors report. The supplier shall also compensate for losses, if any sustained by the CSL due to defective packing and/or marking of the goods not in accordance with the terms of contract. The time limits for filing claims under clauses above shall be generally 180 days from the date of complete discharge of goods.</p>	
29	<p>CSL reserves the right to alter, modify the scope of supply at its discretion and in consistent with the policy of the Government of India and statutory bodies under them as applicable to the contract from time to time.</p>	
30	<p><b>CSL reserves the right to commercially reject the offer if compliance is not issued to terms at Sl. No.14, 15, 16, 17 &amp; 18 without any further clarification / notice / communication in this regard from M/s. Cochin Shipyard Ltd., even though the offer is technically acceptable.</b></p>	
31	<p><b><u>Option Clause:</u></b>  <b>CSL has an option for ordering 10 more shipsets at same price, terms &amp; conditions of the purchase order for 20 confirmed quantity, subject to confirmation on placement of order on or before 31<sup>st</sup> December 2021. In case of any reduction in price from above confirmed purchase order price for the optional vessels, the same shall be separately confirmed in the techno-commercial offer. The offer shall be considered for further processing only subject to confirmation on above point. However L1 determination shall be based on the cost of confirmed 20 vessels.</b></p>	
32	<p>Confirmation to the Eligibility Criteria at Encl.1/A</p>	

<b>Tender condition - Preference to Make in India</b>		
A	Purchase preference in accordance with Public procurement (Preference to Make in India Order - 2017) Order from Department of Promotion of Industry and Internal Trade P - 45021 /2/2017/-B.E -II dt ,4.6.2020 and as amended from time to time shall be applicable as per below	
1	In the procurement of all goods/services/works in respect of which there is sufficient local capacity/local competition , only Class I Local suppliers shall be eligible to bid irrespective of purchase value	
2	In the procurement of all goods/services /works which are not covered as above and with estimated value of purchase less than Rs 200.0 Crores , only Class I local suppliers alongwith Class II local suppliers shall be eligible to bid.	
<b>Purchase preferences for Class I local suppliers</b>		
B	In the procurement of goods/works covered under 2 above and which are divisible in nature , Class I local supplier shall be eligible for Purchase preference over Class II/Non local supplier as per following	
1	If L1 bid is not a Class I local supplier , 50% of the order quantity shall be awarded to L1. Thereafter the lowest bidder among Class I local supplier will be invited to match the L1 price for the remaining 50% quantity subject to Class I local supplier quoted price falling within 20% margin. Contract for that quantity shall be awarded to such Class I local supplier subject to matching L1 price. In case such lowest eligible Class I local supplier fails to match L1 price or accept less than offered quantity , next higher Class I local supplier within 20% margin shall be invited to match the L1 price for the remaining qty and so on . If some quantity is left uncovered on Class I local supplier , such balance quantity shall be ordered on L1 bidder.	
2	For procurements that are not divisible in nature and in procurement of services evaluated on price alone , Class I local supplier shall get purchase preference over Class II/Non local supplier as per below	
3	If L1 is not a Class I local supplier , lowest bidder among Class I local supplier will be invited to match L1 price subject to Class I local supplier quoted price falling within 20% of L1 price and contract will be awarded to such Class I local supplier,subject to matching L1 price. In case such lowest eligible Class I local supplier fails to match L1 price, procedure same as para 3 above will be opted .In case none of Class I local suppliers within 20% margin matches L1 price, contract shall be awarded to L1 bidder. THE purchase preference as above will be only for Class I local supplier and Class II local supplier will not be eligible for any Purchase preference	
C	Local content requirement to categorise a supplier as Class I/ClassII/Non local supplier shall be as per below . Definition of local content shall be as per order dt 4.6.2020 ie amount of value added in India which shall be the total value of the item procured (excluding net domestic indirect taxes) minus the vaue of import content in the item (including all customs duties) as a proportion of total value in percentage.	
1	Class I -Local content equal to or greater than 50%	
2	Class II-Local content greater than 20% , less than 50%	
3	Non local -Local content less than 20%	

D	Declaration of local content	
1	Class I local supplier /Class II local supplier at the time of tender shall indicate % of local content and provide self certification that offered item shall meet the local content requirement for ClassI/Class II as applicable including details of locations at which local value addition is made.	
2	In case of procurement for a value in excess of Rs 10.0 Crores Class I/ClassII local supplier is to provide a certificate from statutory auditor/cost auditor(for companies) /practising cost accountant/Chartered accountant (suppliers other than companies) indicating % of local content	
3	Verification of the Certificates issued by the bidder shall be carried out by CSL on random basis. False declarations will attract actions as stipulated in the order referred , including other actions as permissible by law.	
4	Exemption is applicable from provisions of order for purchases with estimated values less than Rs 5.0 lakhs	
5	Notwithstanding above , exemptions for meeting local content as per relevant Clause of order dt 4.6.2020 and as amended from time to time shall apply.	

**Tender conditions for Restriction of bidders sharing land border with India vide Office memorandum dt 23.7.2020 Order - Public Procurement no 1 dt 23.7.2020, Order no 2 dt 23.7.2020 and Order no 3 dt 24.7.2020**

A	Requirement of registration	
1	Any bidder from a country which shares a land border with India will be eligible to bid in this tender only if the bidder is registered with competent authority as per C below .In works contracts , including turkey contracts , contractors shall not be allowed to sub contract works to any contractor from a country which shares a land border with India unless such contractor is registered with Competent authority. Relevant certificate to be submitted by bidder from a country which shares land border with India except for bidders to which Govt of India has extended lines of Credit or in which Govt of India has development projects,alongwith the offer as proof of registration with competent authority , failing which the offer will not be considered. A certificate is to be submitted by the bidder for compliance with the order referred above alongwith tender documents for consideration of offer(Wordings are as per Clause below) .If such certificate given by a bidder whose bid is accepted is found to be false, this would be a ground for immediate termination and further legal action in accordance with law.	
2	Wordings of certificate to be submitted alongwith tender documents	
	I have read the clause regarding restrictions on procurement from a bidder of a country which shares a land border with India. I hereby certify that this bidder is not from such a country or , if from such a country, has been registered with the competent authority. I hereby certify that this bidder fulfils all requirements in this regard and is eligible to be considered . (Evidence of valid registration by the competent authority shall be attached wherever applicable) .	
2	Wordings of certificate to be submitted alongwith tender documents for Works involving possibility of sub contracting	

	I have read the clause regarding restrictions on procurement from a bidder of a country which shares a land border with India and on sub contracting to contractors from such countries . I certify that this bidder is not from such a country or if from such a country has been registered with the competent authority and will not subcontract any work to a contractor from such countries unless such contractor is registered with the competent authority . I hereby certify that this bidder fulfils all requirements in this regard and is eligible to be considered(Evidence of valid registration by the competent authority shall be attached wherever applicable)
<b>B</b>	<b>Validity of registration</b>
<b>1</b>	Registration should be valid at the time of submission of bids and at the time of acceptance of bids. In respect of supply otherwise than by tender, registration should be valid at the time of placement of order.If the bidder is validly registered at the time of acceptance /order placement , registration shall not be a relevant consideration during contract execution.
<b>C</b>	<b>Competent authority and Procedure for registration</b>
<b>1</b>	The competent authority for the purpose of registration under the order shall be Registration committee constituted by the Departemnt of Promotion of Industry and Internal Trade(DPIIT) . Details of the committee and procedure for registration and restrictions shall be as per Ann I of the Order - Public Procurement no 1 dt 23.7.2020 issued by Ministry of Finance , department of Expenditure.
<b>D</b>	<b>Definition of Bidder and Bidder from a country sharing land border with India</b>
<b>1</b>	Bidder is defined as any person or firm or company including any ,member of a consortium or joint venture , every artificial, juridical person not falling in any of the descriptions of bidders stated hereinbefore , including any agency , branch or office controlled by such person , participating in a procurement process.
<b>2</b>	"Bidder from a country which shares a land border with India" for the purpose of this Order means:- a) An entity incorporated, established or registered in such a country; or b) A subsidiary of an entity incorporated, established or registered in such a country; or c) An entity substantially controlled through entities incorporated, established or registered in such a country; or d) An entity whose beneficial owner is situated in such a country; or e) An Indian (or other) agent of such an entity; or f) A natural person who is a citizen of such a country; or g) A constitution or joint venture where any member of the consortium or joint venture falls under any of the above.
<b>3</b>	<b>Type of business entity</b> (Private Limited Company/ Public Limited Company/ Sole Proprietorship/ One Person Company/ Partnership/ Limited Liability Partnership/ Joint Venture/ Trust/ NGO) In case of incorporated entity - to attach certificate of incorporation
	<b>Beneficial Owners</b> - as defined in the Department of Expenditure Order (Public Procurement No.1) issued vide No. F.No.6/18/2019-PPD dated 23 <sup>rd</sup> July, 2020. Details of all beneficial owners having entitlement of more than 01% of shares or capital or profit to be given, in the format as given in Annexure-I duly certified by practicing Chartered Account in India.

**PRICE BID FORMAT**

Sl. No	DESCRIPTION	Total Qty.	Unit Rate/ Set (INR)	Total Rate (INR)
1	SUPPLY & INSTALLATION OF SANDWICH PUF PANELS FOR FISH HOLD	20 Sets		
A	TOTAL BASIC PRICE FOR 20 VESSELS			
B	PACKING & FORWARDING CHARGES (%), if any			
C	OTHER CHARGES (%), if any			
D	FREIGHT CHARGES (%), if any			
E	TAXES (if any)			
<b>TOTAL C&amp;F PRICE AT TEBMA SHIPYARD LTD., UDUPI FOR 20 VESSELS</b>				

**Note:**

- (i) L1 shall be determined based on the price for the above confirmed 20 shipsets.
- (ii) L1 shall be determined without considering GST/IGST (Refers to taxes in India).
- (iii) Unpriced price bid format (which is an exact replica of the price bid except that the price is blanked) to be submitted along with techno commercial bid with details like percentage of taxes & duties applicable and stating "Quoted" or "Not Quoted" or "Not Applicable" or "By CSL" to be mentioned for each line item.
- (iv) CSL has an option for ordering 10 more shipsets at same Purchase order rate, terms & conditions subject to confirmation of order on or before 31<sup>st</sup> December 2021. In case of any reduction in price for above optional vessels, the same shall be indicated in the price bid as below:

**Discount for Optional 10 Vessels: ..... (in %) if any.**

Signature :

Name & Address of the firm:

## OPTIONAL PRICE BID FORMAT

Sl. No.	DESCRIPTION	Unit Rate (INR)
1	The Unit Price per meter square (m2) for the supply and installation of each sandwich panels	
2	MATERIAL FOR FISH HOLD INSIDE PARTITIONS  (Good quality Anjili wooden planks with soft part fully removed having adequate length as shown in the attached drawing having finished width of each plank 1 feet (4 Nos. Plank on each partition) and thickness 25 mm approx.) - Refer Clause No.4 of PTS	
3	SUPPLY & INSTALLATION OF WOODEN PARTITIONS AND SUPPORTING STRUCTURE (Refer Annexure-1 of PTS)	
	Square Tube	
	C channel	
	Other Consumables	
<b>(The above prices shall not be considered for the determination of L1 bidder)</b>		

Signature :

Name & Address of the firm:

BANK GUARANTEE IN LIEU OF SECURITY DEPOSIT/  
WARRANTY GUARANTEE

To

COCHIN SHIPYARD LTD

(GOVT. OF INDIA ENTERPRISE,)

PO BAG No. 1653 , PERUMANOOR PO, COCHIN 682 015.

WHEREAS .....(Name & Address of Supplier) (hereinafter called "the Supplier") has undertaken, in pursuance of Contract..... No.....  
Dated: ..... to execute ..... (Name of Contract and brief description of works) (hereinafter called "the Contract").

AND WHEREAS it has been stipulated by COCHIN SHIPYARD LTD (The Buyer - hereinafter called "CSL ") in the said contract that the Supplier shall furnish CSL with a Bank Guarantee for the sum specified therein as security for compliance with the Supplier's obligations in accordance with the Contract.

AND WHEREAS we have agreed to give the Supplier such a Bank Guarantee.

NOW THEREFORE we ..... (Name of the Bank) having its Head Office at .....(Address of Head Office) and acting through its branch office at ..... (Address of the executing branch) (hereinafter called "the Bank") hereby affirm that we are the Guarantor and responsible to CSL , on behalf of the Supplier up to a total of ..... (amount of Guarantee) .....in words).

We, the bank, hereby irrevocably undertake to pay you any amount not exceeding in total the Guarantee Amount upon receipt by us of your demand in writing accompanied by the following documents:

1. Your signed statement certifying that the Supplier is in breach of his obligation(s) under the Contract and the respect in which the Supplier is in breach.
2. Your signed statement certifying that the Supplier has been given a prior written notice by email from you to make good the aforesaid breach and that the Supplier still failed to fulfill the Contract within 30 days of such notice. A copy of such notice given by email to the Supplier shall be attached to the demand for payment.

Any demand for payment should contain your authorized signatures which must be authorized by your bankers or by a notary public.

We, the Bank, further agree that no change or addition to or other modification of the terms of the Contract or of the Works to be performed there under or of any of the Contract documents which may be made between CSL and the Supplier shall in any way release us from any liability under this guarantee, and we hereby waive notice of any such change, addition or modification. We, the Bank, further agree that any change in the constitution of the said contractor or the said bank shall not discharge our liability hereunder.



Notwithstanding anything contained herein:

1. Our liability under this Bank Guarantee shall not exceed .....  
(..... only).
2. This Bank Guarantee shall be valid up to (date) and
3. We are liable to pay the guaranteed amount or any part thereof under this bank guarantee only and only if CSL serve upon us a written claim or demand on or before .....(validity date) .

Any demand for payment under this guarantee must be received by us at this office during working hours on or before the validity date. Should we receive no claim from you by the validity date, our liability to you will cease and the guarantee will definitely become null and void whether returned to us or not.

Yours truly,  
Signature and seal of the  
guarantor:.....

Name of  
Bank:.....

Address: .....  
Date:.....

[1] An amount shall be inserted by the Guarantor, representing the percentage of the Contract Price specified in the Contract and denominated in respective Dollars / Indian Rupees/Other Currency.

**PRE CONTRACT INTEGRITY PACT****COCHIN SHIPYARD LIMITED**  
**MATERIALS DEPARTMENT****General**

This pre-bid pre-contract Agreement (hereinafter called the Integrity Pact) is made on .... day of the month of ....., between, on one hand, the President of India acting through Deputy General Manager, Cochin Shipyard Ltd (CSL) having its registered office at Cochin, Kerala India (hereinafter called the “PRINCIPAL”, which expression shall mean and include, unless the context otherwise requires, his successors in office and assigns) of the First part and M/s.....represented by Shri....., Chief Executive Officer (hereinafter called the “BIDDER/Seller” which expression shall mean and include, unless the context otherwise requires, his successors and permitted assigns) of the second part.

WHEREAS the PRINCIPAL proposes to procure ..... and the BIDDER/Seller is willing to offer/has offered the stores and

WHEREAS the BIDDER is a private company / public company / Government undertaking / partnership/registered export agency, constituted in accordance with the relevant law in the matter and the PRINCIPAL is a Government of India PSU performing its functions on behalf of The President of India.

**NOW, THEREFORE,**

To avoid all forms of corruption by following a system that is fair, transparent and free from any influence/prejudiced dealings prior to, during and subsequent to the currency of the contract to be entered into with a view to:-

Enabling the PRINCIPAL to obtain the desired said stores/equipment/item at a competition price in conformity with the defined specifications by avoiding the high cost and the distortionary impact of corruption on public procurement, and

Enabling BIDDERS to abstain from bribing or indulging in any corrupt practice in order to secure the contract by providing assurance to them that their competitors will also abstain from bribing and other corrupt practices and the PRINCIPAL will commit to prevent corruption, in any form, by its officials by following transparent procedures.

The parties hereto hereby agree to enter into this Integrity Pact and agree as follows:-

**Commitments of the PRINCIPAL**

- 1.1 The PRINCIPAL undertakes that no official of the PRINCIPAL, connected directly or indirectly with the contract, will demand, take a promise for or accept, directly or through intermediaries, any bribe, consideration, gift, reward, favour or any material or immaterial benefit or any other advantage from the BIDDER, either for themselves or for any person, organization or third party related to the contract in exchange for an advantage in the bidding process, bid evaluation, contracting on implementation process related to the contract.

- 1.2 The PRINCIPAL will, during the pre-contract stage, treat all BIDDERS alike and will provide to all BIDDERS the same information and will not provide any such information to any particular BIDDER which could afford an advantage to that particular BIDDER in comparison to other BIDDERS.
  - 1.3 The officials of the PRINCIPAL will report to the appropriate Government office any attempted or completed breaches of the above commitments as well as any substantial suspicion of such a breach.
- 2 In case any such preceding misconduct on the part of such official(s) is reported by the BIDDER to the PRINCIPAL with full and verifiable facts and the same is prima facie found to be correct by the PRINCIPAL, necessary disciplinary proceedings, or any other action as deemed fit, including criminal proceedings may be initiated by the PRINCIPAL and such a person shall be debarred from further dealings related to the contract process. In such a case while an enquiry is being conducted by the PRINCIPAL the proceedings under the contract would not be stalled.

#### **Commitments of BIDDERS**

4. The BIDDER commits itself to take all measures necessary to prevent corrupt practices, unfair means and illegal activities during any stage of its bid or during any pre-contract or post-contract stage in order to secure the contract or in furtherance to secure it and in particular commit itself to the following:-
  - 3.1 The BIDDER will not offer, directly or through intermediaries, any bribe, gift, consideration, reward, favour, any material or immaterial benefit or other advantage, commission, fees, brokerage or inducement to any official of the PRINCIPAL, connected directly or indirectly with the bidding process, or to any person, organization or third party related to the contract in exchange for any advantage in the bidding, evaluation, contracting and implementation of the contract.
  - 3.2 The BIDDER further undertakes that it has not given, offered or promised to give, directly or indirectly any bribe, gift, consideration, reward, favour, any material or immaterial benefit or other advantage, commission, fees, brokerage or inducement to any official of the PRINCIPAL or otherwise in procuring the Contract or forbearing to do or having done any act in relation to the obtaining or execution of the contract of any other contract with the government for showing or forbearing to show favour or disfavor to any person in relation to the contract of any other contract with the Government.
  - 3.3 BIDDERS of foreign origin shall disclose the name and address of their Indian agents and representatives, if any and Indian BIDDERS shall disclose their foreign principals or associates, if any.
  - 3.4 BIDDERS shall disclose the payments to be made by them to their Indian agents/brokers or any other intermediary, in connection with this bid/contract and the payments have to be in Indian Rupees only.

- 3.5** The BIDDER further confirms and declares to the PRINCIPAL that the BIDDER is the original manufacturer/ integrator/authorized agent of the stores/equipment/items and has not engaged any individual or firm or company whether Indian or foreign to intercede, facilitate or in any way to recommend to the PRINCIPAL or any of its functionaries, whether officially or unofficially to the award of the contract to the BIDDER, nor has any amount been paid, promised or intended to be paid to any such individual, firm or company in respect of any such intercession, facilitation or recommendation.
- 3.6** The BIDDER, either while presenting the bid or during pre-contract negotiations or before signing the contract, shall disclose any payments he has made, is committed to or intends to make to officials of the PRINCIPAL or their family members, agents, brokers or any other intermediaries in connection with the contract and the details of services agreed upon for such payments.
- 3.7** The BIDDER will not collude with other parties interested in the contract to impair the transparency, fairness and progress of the bidding process, bid evaluation, contracting and implementation of the contract.
- 3.8** The BIDDER will not accept any advantage in exchange for any corrupt practice, unfair means and illegal activities.
- 3.9** The BIDDER shall not use improperly, for purposes of competition or personal gain, pass on to others, any information provided by the PRINCIPAL as part of the business relationship, regarding plans, technical proposals and business details, including information contained in any electronic data carrier. The BIDDER also undertakes to exercise due and adequate care lest any such information is divulged.
- 3.10** The BIDDER commits to refrain from giving any complaint directly or through any other manner without supporting it with full and verifiable facts.
- 3.11** The BIDDER shall not instigate or cause to instigate any third person to commit any of the actions mentioned above.
- 3.12** If the BIDDER or any employee of the BIDDER or any person acting on behalf of the BIDDER, either directly or indirectly, is a relative of any of the officers of the PRINCIPAL, or alternatively, if any relative of an officer of the PRINCIPAL has financial interest/stake in the BIDDER's firm, the same shall be disclosed by the BIDDER at the time of filing of tender.
- The term 'relative' for this purpose would be as defined in section 6 of the Companies Act 1956.
- 3.13** The BIDDER shall not lend to or borrow any money from or enter into any monetary dealings or transactions, directly or indirectly, with any employee or the PRINCIPAL.

**4. Previous Transgression**

- 4.1** The BIDDER declares that no previous transgression occurred in the last three years immediately before signing of this Integrity Pact, with any other company in any country in respect of any corrupt practices envisaged hereunder or with any Public Sector Enterprise in India or any Government Department in India that could justify; BIDDER's exclusion from the tender process.
- 4.2** The BIDDER agrees that if it makes incorrect statement on this subject, BIDDER can be disqualified from the tender process or the contract, if already awarded, can be terminated for such reason.

**5. Earnest Money (Security Deposit)**

- 5.1** While submitting commercial bid, the BIDDER shall deposit an amount **NIL** (to be specified in RFP) as Earnest Money as applicable/Security Deposit, with the PRINCIPAL through any of the following instruments:

- (i) Bank Draft of Pay Order in favor of CSL.
- (ii) A confirmed guarantee by an Indian Nationalized Bank, promising payment of the guaranteed sum to the PRINCIPAL on demand within three working days without any demur whatsoever and without seeking any reasons whatsoever. The demand for payment by the PRINCIPAL shall be treated as conclusive proof of payment.
- (iii) Any other mode or through any other instrument (to be specified in the RFP).

- 5.2** The Earnest Money if applicable/Security Deposit shall be valid upto the complete conclusion of the contractual obligations to the complete satisfaction of both the BIDDER and the PRINCIPAL, including warranty period.

- 5.3** In case of the successful BIDDER a clause would also be incorporated in the Article pertaining to Performance Bond in the Purchase Contract that the provisions of sanctions for Violation shall be applicable for forfeiture of Performance Bond in case of a decision by the PRINCIPAL to forfeit the same without assigning any reason for imposing sanction for violation of this Pact.

- 5.4** No interest shall be payable by the PRINCIPAL to the BIDDER on Earnest Money/Security Deposit for the period of its currency.

**6 Sanctions for Violations**

- 6.1** Any breach of the aforesaid provisions by the BIDDER or any one employed by it or acting on its behalf (whether with or without the knowledge of the

BIDDER) shall entitle the PRINCIPAL to take all or any one of the following actions, wherever required:-

- (i) To immediately call off the pre contract negotiations without assigning any reason or giving any; compensation to the BIDDER. However, the proceedings with the other BIDDER(s) would continue.
- (ii) The Earnest Money Deposit (in pre-contract stage) and/or Security Deposit/ Performance Bond (after the contract is signed) shall stand forfeited either fully or partially, as decided by the PRINCIPAL and the PRINCIPAL shall not be required to assign any reason therefore.
- (iii) To immediately cancel the contract, if already signed, without giving any compensation to the BIDDER.
- (iv) To recover all sums already paid by the PRINCIPAL, and in the case of an Indian BIDDER with interest thereon at 2% above the prevailing Prime Lending Rate of State Bank of India, while in case of a BIDDER from a country other than India with interest thereon at 2% above the LIBOR (London Inter Bank Offer Rate). If any outstanding payment is due to the BIDDER from the PRINCIPAL in connection with any other contract for any other stores, such outstanding payment could also be utilized to recover the aforesaid sum and interest.
- (v) To encash the advance bank guarantee and performance bond/warranty bond, if furnished by the BIDDER, in order to recover the payments, already made by the PRINCIPAL, along with interest.
- (vi) To cancel all or any other contracts with the BIDDER. The BIDDER shall be liable to pay compensation for any loss or damage to the PRINCIPAL resulting from such cancellation/recession and the PRINCIPAL shall be entitled to deduct the amount so payable from the money(s) due to the BIDDER.
- (vii) To debar the BIDDER from participating in the future bidding processes of CSL for a minimum period as deemed appropriate, which any be further extended at the discretion of the PRINCIPAL.
- (viii) To recover all sums paid in violation of this Pact by BIDDER(s) to any middleman or agent or broker with a view to securing the contract.
- (ix) In cases where irrevocable Letters of Credit have been received in respect of any contract signed by the PRINCIPAL with the BIDDER, the same shall not be opened.

(x) Forfeiture of Performance Bond in case of a decision by the PRINCIPAL to forfeit the same without assigning any reason for imposing sanction for violation of this pact.

6.2 The PRINCIPAL will be entitled to take all or any of the actions mentioned at para 6.1(i) to (x) of this pact also on the Commission by the BIDDER or any one employed by it or acting on its behalf (whether with or without the knowledge of the BIDDER), of an offence as defined in chapter IX of the Indian Penal code, 1860 or Prevention of Corruption Act, 1988 or any other statute enacted for prevention of corruption.

6.3 The decision of the PRINCIPAL to the effect that a breach of the provisions of this pact has been committed by the BIDDER shall be binding on the BIDDER. However, the BIDDER can approach the Independent Monitor(s) appointed for the purposes this Pact.

7 **Fall Clause**

7.1 The BIDDER undertakes that it has not supplied/is not supplying similar product/systems/items or subsystems at a price lower than that offered in the present bid in respect of any other Ministry/Department of the Government of India or PSU and if it is found at any stage that similar product/systems or sub systems/items was supplied by the BIDDER to any other Ministry/Department of the Government of India or PSU at a lower price, then that very price, with due allowance for elapsed time, will be applicable to the present case and the difference in the cost would be refunded by the BIDDER to the PRINCIPAL, if the contract has already been concluded.

8 **Independent Monitors**

8.1 The PRINCIPAL has appointed Independent Monitor (hereinafter referred to as Monitor) for this Pact in consultation with the Central Vigilance Commission.

.....  
.....  
.....  
.....  
.....  
.....

8.2 The task of the Monitors shall be to review independently and objectively, whether and to what extend the parties comply with the obligations under this Pact.

8.3 The Monitors shall not be subject to instructions by the representatives of the parties and perform their functions neutrally and independently.

8.4 Both the parties accept that the Monitors have the right to access all the documents relating to the project/procurement, including minutes of meetings.

- 8.5** As soon as the Monitor notices, or has reason to believe, a violation of this pact, he will so inform the Authority designated by the PRINCIPAL.
- 8.6** The PRINCIPAL accepts that the Monitor has the right to access without restriction to all Project documentation of the BUYER including that provided by the BIDDER. The BIDDER will also grant the Monitor, upon his request and demonstration of a valid interest, unlimited access to his project documentation. The same is applicable to Subcontractors. The Monitor shall be under contractual obligation to treat the information and documents of the BIDDER/Subcontractor(s) with confidentiality.
- 8.7** The PRINCIPAL will provide to the Monitor sufficient information about all meetings among the parties related to the Project provided such meetings could have an impact on the contractual relations between the parties. The parties will offer to the Monitor the option to participate in such meetings.
- 8.8** The Monitor will submit a written report to the designated Authority of PRINCIPAL /Secretary in the Department/ within 8 to 10 weeks from the date of reference or intimation to him by the PRINCIPAL /BIDDER and, should the occasion arise, submit proposals for correcting problematic situations.

## **9 Facilitation of Investigation**

In case of any allegation of violation of any provisions of this pact or payment of commission, the PRINCIPAL or its agencies shall be entitled to examine all the documents including the Books of Accounts of the BIDDER. The BIDDER shall provide necessary information and documents in English and shall extend all possible help of the purpose of such examination/inspection.

## **10 Law and Place of Jurisdiction**

This Pact is subject to Indian Law. The place of performance and jurisdiction is the seat of the PRINCIPAL.

## **11 Other Legal Actions**

The actions stipulated in this Integrity Pact are without prejudice to any other legal action that may follow in accordance with the provisions of the extent law in force relating to any civil or criminal proceedings.

## **12 Validity**

**12.1** The validity of this Integrity Pact shall be from date of its signing and extend upto 5 years or the complete execution of the contract to the satisfaction of both the PRINCIPAL and the BIDDER/Seller, including warranty period, whichever is later. In case BIDDER is unsuccessful, this Integrity Pact shall expire after six months from the date of the signing of the contract.



**12.2** Should one or several provisions of this Pact turn out to be invalid; the remainder of this pact shall remain valid. In this case, the parties will strive to come to an agreement to their original intentions.

**13** The parties hereby sign this Integrity Pact at.....on.....

**PRINCIPAL**

Name of the Officer  
Designation  
Dept./MINISTRY/PSU

**BIDDER**

CHIEF EXECUTIVE OFFICER

Witness

1.....  
2.....

Witness

1.....  
2.....

\* Provisions of these clauses would need to be amended/deleted in line with the policy of the BUYER in regard to involvement of Indian agents of foreign suppliers.