



TENDER NOTICE

MAT/CSH3/0001/24-25/Uptime/Transportation_2

17th Feb 2025

CSL Contact Person: -

Aravind MJ

Asst. Manager (Materials Department)

Phone No : 0484 2501263

e-mail : aravind.mj@cochinshipyard.in

Subject:-	SEA TRANSPORTATION OF BREAK-BULK CARGO FROM EXW VUNG TAU, VIETNAM, DELIVERY TO COCHIN SHIPYARD LIMITED AT COCHIN
-----------	---

Dear Sir,

Sealed tenders are invited for Sea transportation of Break-bulk cargo from EXW Vung Tau, Vietnam to Cochin Shipyard Limited at Cochin. The Bidder shall read and imbibe the Annexure 'A' Scope of Work, CSL requirements, prequalification criteria and instructions to bidder in full. Submission of offer shall be only after full understanding of the tender requirements.

1. Mode of submission of offers

a) Offers should be submitted in TWO separate sealed covers as mentioned below:-

- i) Part-I "Techno-Commercial Offer & EMD"
- ii) Part-II "Price offer"

- Each cover shall super scribe the Tender enquiry title, Cover content description as above, the tender number (MAT/CSH3/0001/24-25/Uptime/Transportation_2 dated 17th Feb 2025), due date and name & address of the bidders.
- Tenders are to be addressed to The Deputy General manager (Materials), Materials Department, Cochin Shipyard Limited, Cochin, and are to be deposited in the tender box at Materials Department, Cochin Shipyard Limited., Cochin.
- Tender documents over email also acceptable. However, the bidders shall ensure that the files are attached as mentioned below:-

- a) Document 1 – Techno-Commercial bid in password protected format (Pre-qualification documents, Commercial terms, EMD amount transfer slip if applicable from the bank, Price bid without Price and General Terms & Conditions - PDF).
- b) Document 2 - Price Bid (Password protected PDF)

Page 1 of 3



b) Following to be noted/complied/submitted with regard to the tender in addition to general tender requirements.

- i. Submission of EMD along with Techno-commercial offer (Part I) as per Annexure 'F' OR on-line transfer of EMD amount to CSL account. Please refer clause No (11) of Annexure 'B' for details.
- ii. Pre-Qualification criteria as per Annexure 'D'.
- iii. Unpriced bid (Price bid with prices blanked out) as perform at Annexure 'C' shall be submitted along with the techno-commercial cover.
- iv. Duly filled and signed General Terms & Conditions as per Annexure 'B' along with declarations mentioned therein, duly filled and signed
- v. Duly filled and signed Pre-Contract Integrity pact as per Annexure 'H'.

2. Offers received without EMD, Pre-Qualification Criteria (with supporting documents), Price format (unpriced format), Filled General Terms & Conditions and Pre-Contract Integrity Pact duly filled and signed as stipulated will not be considered for the further process of tender. Submission of offer shall be only after full understanding of the tender requirements and no request for change in scope/ terms and conditions shall be admitted post finalization of the bid. Offers received without complying the prequalification criteria will be summarily rejected without any further communication from CSL side.

3. Cardinal dates of the tender are as below:

Last date of submission of offers : **27th February 2025 at 15:00 Hrs**
(Techno commercial bid and Price bid shall be submitted)

Tender opening date and time : **27th February 2025 at 15:30 Hrs**

Only Part I bids "Techno-commercial cover" will be opened on scheduled tender opening date and time.

4. Price bid (Part II) opening shall be intimated to techno-commercially acceptable bidders and authorized representative of techno-commercially accepted bidders who wish to be present shall be allowed.
5. The bidder shall be familiar with the various rules and regulations, provisions and requirements (including tax related, import related etc.) in India.
6. Contact person for any queries related to the tender.

Mr. Aravind MJ,
Asst. Manager (Materials Department)
Phone No : 0484 2501263
Mobile : 8714630964
e-mail : aravind.mj@cochinshipyard.in

7. List of Annexures:-

Annexure A – Scope of Work.
Annexure B – General Terms & Conditions
Annexure C –Price Bid Format
Annexure D –Qualification Criteria



Annexure E – Cargo details, drawings & lifting plan
Annexure F –Earnest Money Deposit format
Annexure G – Bank Guarantee Format
Annexure H - Pre-Contract Integrity Pact

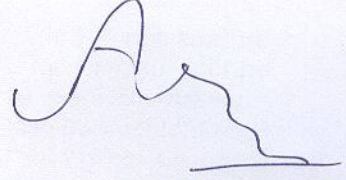

For Deputy General Manager (Materials)
Cochin Shipyard Limited

अरविंद एम जे
ARAVIND M J
सहायक प्रबंधक / Assistant Manager
कोचीन शिपयार्ड लिमिटेड
Cochin Shipyard Ltd.
कोच्ची / Kochi- 15

COCHIN SHIPYARD LIMITED (a Government of India Enterprise)	WORK SCOPE: Sea transportation of Cargo from EXW Vung Tau, Vietnam to Cochin Shipyard Stores at Cochin	Yard No. BY 151-152
	Doc. No. MAT/CSH3/0001/24-25/Uptime/Transportation_2	Dated 17.02.2025
Annexure 'A'		

A. Brief Description of the Organization/AEO Status

Cochin Shipyard Limited (CSL) is a schedule "A" CPSE under the Ministry of Shipping, Port and Waterways, Government of India headquartered in Kochi, Kerala. Cochin Shipyard has been accorded Authorized Economic Operator (AEO) Tier II status by Central Board of Indirect Taxes and Customs (CBIC) for compliance to World Customs Organization (WCO) standards on Supply Chain and Trade security under SAFE Framework. This has enhanced the trade prospects of CSL as the accreditation brings several benefits for trade facilitation including deferred duty payment.

B. Brief Description of Work

Transportation of break-bulk Cargo (Details at Annexure E) from EXW, Vung Tau, Vietnam to the Stores of Cochin Shipyard Limited, Kochi, Kerala. The requirement is for collecting and transportation of items for two vessels, which are similar in size, volume and other characteristics. The tentative date of readiness of items for the first ship set at Shipper premises is 10.03.2025 and for the second ship set is 21.04.2025. The date is tentative and the actual date of readiness shall be formally intimated along with the Purchase Order.

C. Scope of Work

Scope of Work includes the following:-

l) The forwarder shall;

- a) Position suitable vehicle/trailer for transportation of cargo from the shipper premises to the port
- b) Be responsible for all charges incurred related to vehicular movement, permissions & port usage to be in Forwarder's scope.
- c) Receiving, Lifting, Loading, Lashing, Securing of goods into the vehicle at the Shipper premises and during transportation to Cochin Shipyard.
- d) Unloading at Origin/ intermittent port areas/ Destination/ Cochin Port Authority.
- e) Arrange Port permission/ tug or Boat assistance / clearance /Formalities at the Port of Dispatch and at Cochin Port.
- f) All documentation for export, clearance & permissions of break-bulk on ocean going vessels.

COCHIN SHIPYARD LIMITED (a Government of India Enterprise)	WORK SCOPE: Sea transportation of Cargo from EXW Vung Tau, Vietnam to Cochin Shipyard Stores at Cochin	Yard No. BY 151-152
	Doc. No. MAT/CSH3/0001/24-25/Uptime/Transportation_2	Dated 17.02.2025

Annexure 'A'

- g) Arrange Sea freight in Sea Worthy vessel to Cochin port / any major Port in India to meet CSL Schedule. Vessel shall be equipped with Cranes/Lifting Arrangements for unloading at Cochin Port/Destination.
- h) Document presentation & clearance of import items prevailing the Customs duty exemption for CSL within the permitted period of vessel. This shall be the sole responsibility of the bidder and CSL shall not accept any claims thereof.
- i) Demurrage incurred, if any, incurred due to delay in submission of documents will be to Forwarder's account.
- j) Consignment shall be suitably transported by Barge/vessel from Cochin Port/Any major port in India to Cochin Shipyard Stores. All arrangements including port permission, tugs, if required, shall be the responsibility of the freight forwarder. Notwithstanding any omissions herein, all necessary arrangements for safe and timely transport of cargo till CSL premises shall be included in scope and cost of the freight forwarder
- k) Special supports, Jigs, spreader beams and special lifting equipments for lifting the cargo as per lifting plan and for safe transportation of items at various locations, to be provided by Forwarder and the cost towards the same shall be included in the quoted price.
- l) The forwarder shall comply to all lifting instructions and special instructions if any, as stipulated in the Tender document and those communicated by the shipper
- m) All safe practices and requirements to meet insurance and marine standards to be followed for all operations.
- n) It shall be duly noted that the barge/vessel shall enter CSL Dock mouth, the length of which shall be 85m. The Reach of crane to water is restricted to 7m. Transporter shall ensure that the above cardinal data is foreseen while arranging vessel/barge for transportation till CSL Stores. The forwarder shall be solely responsible for ensuring all arrangements to berth the vessel at CSL dock mouth and facilitate smooth unloading with the availability of existing infrastructure at CSL as summarized above.

Note:-

1. Cargo will not be provided with any spreader bars, beams or stools for handling. Lifting points, if any have been indicated in the drawings /schematic along with CG details. Any missing info to be sought prior submission of offer. Forwarder shall arrange necessary spreader Jigs, beams, supports etc necessary for safe lifting and transportation.
2. All the other expenditure including wharfage charges and statutory levies is to be covered in the offered prices

COCHIN SHIPYARD LIMITED (a Government of India Enterprise)	WORK SCOPE: Sea transportation of Cargo from EXW Vung Tau, Vietnam to Cochin Shipyard Stores at Cochin	Yard No. BY 151-152
	Doc. No. MAT/CSH3/0001/24-25/Uptime/Transportation_2	Dated 17.02.2025

Annexure 'A'

3. The requirement is for collecting and transportation of items for two vessels, which are similar in size, volume and other characteristics. The tentative date of readiness of items for the first ship set at shipper premises is 10.03.2025 and for the second ship set is 21.04.2025. The date is tentative and the actual date of readiness shall be formally intimated along with the Purchase Order.
4. In case the forwarder choose any other major port in India as port of discharge, the forwarder shall ensure safe inland transportation of cargo from the port of discharge to CSL Stores, abiding by all statutory regulations including rules for transportation of Over-dimensional cargo promulgated by the competent authority. It shall be the responsibility of the forwarder to complete all necessary clearance procedures including filing IGM and Bill of Entry in the Port of landing. CSL shall be absolved of any responsibility for breach of regulations and legal or financial consequences arising thereof.
5. The value of entire Cargo amounts to INR 17,87,76,000 per ship set.

D. Insurance

The subject goods as per details mentioned in Annexure 'E' shall be insured by CSL. The forwarder shall provide all details such as the type and details of vehicle used for local transportation at the country of exportation and shipment details such as Bill of Lading, weight, & dimensions of cargo. Notwithstanding any omissions herein, all details required for arranging Insurance shall be forwarded prior to shipment. The forwarder shall be responsible for all the financial and legal consequences arising due to lapse on their part in furnishing the information timely. Only the goods shall be covered by CSL insurance and CSL shall not be responsible for arranging insurance for personnel or other movables and shall be absolved from any financial or legal liabilities arising due to non-compliance thereof.

Marine Warranty Survey, if required, shall be to Forwarder scope and prices shall be inclusive of the same

E. License requirements

Forwarder to ensure license requirements, if any for a particular cargo and inform CSL /Shipper to obtain requisite paperwork prior to booking shipment for Export.

F. Packing for Seaworthy transport

COCHIN SHIPYARD LIMITED (a Government of India Enterprise)	WORK SCOPE: Sea transportation of Cargo from EXW Vung Tau, Vietnam to Cochin Shipyard Stores at Cochin	Yard No. BY 151-152
	Doc. No. MAT/CSH3/0001/24-25/Uptime/Transportation_2	Dated 17.02.2025

Annexure 'A'

Forwarder to consider seaworthy packaging based on the nature and weight of the cargo and to ensure packaging and protection to meet marine standards. Forwarder also to consider adequate supports/handling provisions, in addition, for the packaged cargo and Break-bulk cargo which will facilitate easy handling and shifting operations at origin and destination.

The packaging material shall be Non - hazardous and shall be environment friendly.

G. Certification of lifting tackles, Cranes

Forwarder is to ensure that certified tackles, cranes are employed for all operations at origin and at destination. Additionally, prerequisites for insurance, if any also to be ensured.

H. Documents for transport

All documents including Invoice, packing lists to be submitted to CSL for verification prior to shipment. Customs requirements for export and import clearance shall be ensured. The forwarder shall ensure correctness of documentation. CSL shall not be responsible for any mismatch in documentation and consequences arising due to this including demurrages and other financial or legal consequences.

I. Time Frame

Forwarder shall liaison with M/s Uptime International AS and initiate lifting of cargo from Shipper premises at Vung Tau, Vietnam **within 07days** from the receipt of work order from CSL.

Pickup of the entire cargo from the shipper's facility in Vung Tau, Vietnam must be completed by the forwarder **within 07 days** of the work start date.

J. Shipper Details

Contact Person – Mr. Anders Vaagen
Contact No: +4790866659
M/s Uptime International AS
Vung Tau
Vietnam.

K. Cargo Details

COCHIN SHIPYARD LIMITED
(a Government of India Enterprise)

WORK SCOPE: Sea transportation of Cargo from EXW Vung Tau, Vietnam to Cochin Shipyards Stores at Cochin

Yard No. BY 151-152

Doc. No. MAT/CSH3/0001/24-25/Uptime/Transportation_2

Dated 17.02.2025

Annexure 'A'

Cargo information, including drawings and lifting plans, can be found in Annexure 'E'. The quantity of each item indicated therein are for 1 shipset. The forwarder must contact the shipper and conduct a site visit if necessary to fully understand the scope of work. CSL will not accept any claims for additional work resulting from the forwarder's failure to properly assess the requirements.

Informatively, bidders may refer the photos attached at Annexure E for Dock mouth details

No additional claim shall be admitted for the given scope. The bidder is responsible for the assessment of the cargo and for arranging necessary transportation in line with the scope of work. The volume of cargo mentioned in the scope of work document is indicative and any variation in weight /volume within +/- 5 % shall be considered without any additional cost to CSL.

List of items:-

No.	Description	Country of origin	Unit	Qty	Weight (kg)	Weight (kg)	Dim. (mm)	Drawings No:
					Gross	Net		
					102644	1,00,544	Length x Width x High	
I	TOWER	Vietnam	SET	1	70143	69843	29163 x 5550 x 5090	2320000-UI-4020-N-XD-710-5011 2320000-UI-4020-N-XG-710-5010
II	CURSOR	Vietnam	SET	1	16199	15899	10020 x 5500 x 3150	2320000-UI-4020-N-XD-830-0015 2320000-UI-4020-N-XD-830-0017
III	HINGE AND HORIZONTAL E-CHAIN BOX	Vietnam	SET	1	8199	7899	6200 x 4983 x 4300	2320000-UI-4020-N-XD-830-5013 2320000-UI-4020-N-XD-830-5011
IV	SHEAVE SUPPORT JOKE	Vietnam	SET	1	2634	2334	6000 x 650 x 1100	2320000-UI-4020-N-XG-710-5501
V	WINCH PLATFORM AND HANDRAIL, LADDER	Vietnam	SET	1	2459	2159	6870 x 3150 x 2150	2320000-UI-4020-N-XG-710-5711
VI	PLATFORM HANDRAIL AND LADDER	Vietnam	SET	1	2100	1800	6400 x 2000 x 1550	2320000-UI-4020-N-XG-831-4001
VII	TUNNEL AND ACCESSORY	Vietnam	SET	1	910	610	3800 x 1600 x 1700	NA
VIII	40" Container with loose items	Vietnam	PC	1	TBA	TBA		NA

L) Additional info. on Unloading at CSL.

1. Unloading of Tower from Barge

Barge needs to enter the dock mouth pocket

Crane Reach to water – Max. 7 m from berth

Length of dock mouth – ~ 85 m

Above details to be intimated to transporter while giving the order.

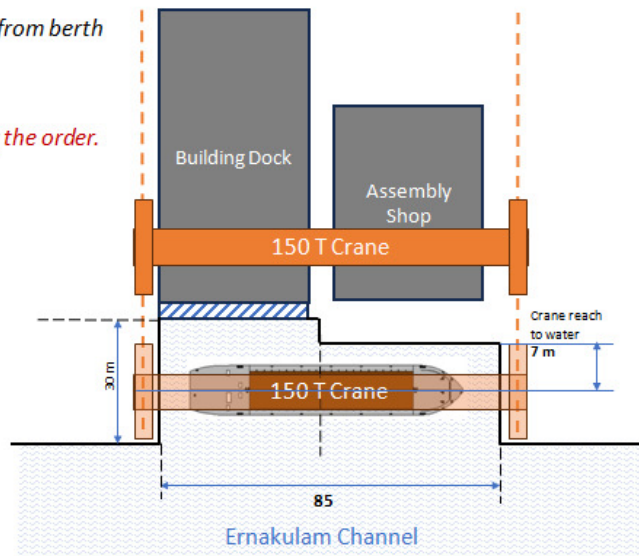

SII	Description
1	<p><u>General Instructions:-</u></p> <p>(a) Tenderers (Only Indian Bidders) are to carefully go through the Scope of Work (Annexure A) for which offers are called for. The bidder is responsible for the assessment of the cargo and for arranging necessary transportation in line with the scope of work and as per conditions mentioned herein. Tenderers have to adhere to above and Receive/ transport /deliver items along with compliance of commercial conditions. Deviations if any shall be indicated in a separate deviation sheet. CSL have full right upon deviations, if any, including rejecting the partial scope/ complied offers.</p> <p>(b) Bidders shall mandatorily meet the Qualification criteria mentioned at Annexure 'D' and duly submit the documents stipulated therein. Only those bidders meeting the qualification criteria mentioned therein shall be qualified techno-commercially and bids submitted without required documents are subject to be rejected summarily</p>
2.	<p><u>Payment Terms</u></p> <p>Payment term is 100 % within 45 days receipt of goods at the Stores of Cochin Shipyard. Payment shall be released upon issuance of Work completion certificate and upon production of the following documents in original:</p> <ol style="list-style-type: none"> 1. Bill of Lading 2. Bill of Entry including Out of Charge by Customs authority 3. Tax Invoice <p>The supplier shall upload copy of tax invoice in CSL Vendor Invoice management portal upon completion of work</p>
3.	<p><u>MSEs, Startups and Make in India</u></p> <p>Local Suppliers (Make In India), MSME firms and Start-ups will be eligible for various relaxations in pre-qualification criteria and other benefits as per the orders promulgated by Government of India. Bidders are advised to refer the details of various Benefits and Relaxation in pre-qualification criteria as published at CSL website (www.cochinshipyard.com) under the Tenders tab for further reference.</p>
4.	<p><u>Delivery</u></p> <p>The Turnaround time for execution of the entire scope of supply as per Tender Conditions (Total turnaround time required for delivery of Cargo at CSL Stores from the receipt of Cargo from Shipper premises at Vung Tau, Vietnam should be indicated in the offer. The firm shall collect the cargo from shipper premises within 14 days of issuance of formal purchase order from CSL.</p> <p>The requirement is for collecting and transportation of items for two vessels, which are similar in size, volume and other characteristics. The tentative date of readiness of items for the first shipset at Shipper premises is 10.03.2025 and for the second ship set is 21.04.2025. The date is tentative and the actual date of readiness shall be formally intimated along with the Purchase Order</p> <p>Refer Annexure E for Packing list, Item details and Weight/dimensions details of Break-bulk cargo</p>

5.	<p><u>Shipment/Clearance</u></p> <p>(a) Supplier is responsible for ensuring seamless end to end activities including but not restricted to preparing documents for export, clearance, filing Bill of Entry on time and safe transportation of cargo. Any demurrage/penalty incurred due to default of the above responsibilities shall be charged from the suppliers' account</p>
6.	<p>If the supplier fails to execute the service as per contract specification and fails to collect the goods or deliver within the delivery date or violate any of the terms and conditions of the purchase order, CSL shall have the following rights.</p> <p>(a) To cancel the order partially or full with 15 days notice and to forfeit the security deposit, if any.</p> <p>(b) To impose tender holiday for the vendor for an appropriate period as decided by CSL</p> <p>(c) Risk Purchase To initiate alternate procurement action at the risk and cost of the supplier. This Risk Purchase clause is applicable only in the case of total order/ contract value (excluding taxes and duties) is Rs.20 lakhs and above (or equivalent foreign currency). Cases of value less than 20 lakhs will be addressed by serving appropriate caution/ warning notice to the firm.</p>
7.	<p><u>Pricing:</u></p> <p>(a) Exchange rate variation will not be applicable and the prices shall be fixed for an order within validity period.</p> <p>(b) Bidders shall quote in INR only.</p> <p>(c) <u>Validity</u>. Prices should be valid for acceptance for a period of four months from the date of tender opening.</p> <p>(d) No enhancement of rate for whatsoever cause will be allowed once the offer is accepted and an order is placed. Withdrawal of the quotation after it is accepted or failure to make the supply within the stipulated delivery period, will entail cancellation of the order and forfeiture of Earnest Money Deposit/Security deposit, if any and/or risk purchase, without prejudice to other penal actions, including tender holiday after serving show cause notices, as deemed fit.</p> <p>(e) Conditional discounts, if any, will not be reckoned for tender evaluation/ comparison purpose. However, if the bidder becomes L1 at original offer, conditional discount shall also be considered.</p> <p>(f) Unpriced bid (price bid without price) duly signed is to be submitted along with techno-commercial offer in the price format, if provided. . In the event price bid is different from the unpriced format already submitted, yard reserves the right to reject the offer at our discretion without any further discussions. Details of optional items, if any, should be indicated under separate heading in the Techno commercial bid and the respective price details should also be given in the price bid. Combining of figures against more than one item and ambiguous clauses will lead to rejection of the bid.</p> <p>(g) If, in the price structure quoted for the required material/ item, there is discrepancy between the unit price and the total price (which is obtained by multiplying the unit price by the quantity), the unit price shall prevail and the total price corrected accordingly. If there is an error in a total corresponding to the addition or subtraction of subtotals, the subtotals shall prevail and</p>

	<p>the total shall be corrected. If there is a discrepancy between words and figures, amount in words of respective figures shall prevail. If the bidder does not agree to the observation of the CSL, the tender is liable to be rejected and the same shall be intimated.</p> <p>(h) L1 shall be determined based on the overall cost for execution of the scope of tender</p> <p>(i) No enhancement of rate for whatever cause will be allowed once the offer is accepted and an order is placed. Withdrawal of the quotation after it is accepted or failure to make the supply within the stipulated delivery period will entail cancellation of the order and forfeiture of Earnest Money Deposit/ Security deposit, if any and/ or risk purchase without prejudice to other penal actions including tender holiday after serving show cause notice , as deemed fit.</p>
8.	<p><u>Taxes and Duties:</u></p> <p>(a) Taxes and duties, if any, payable extra are to be indicated in the price part for single bid and in techno commercial part and price part (in the case of 2 bid tender).</p> <p>(b) The bidder, unless specified otherwise in the offer, shall bear all tax liabilities (including interest and penalty), duties, Govt. Levies etc. including GST, Excise Duty, Customs Duty, Corporate and personnel taxes levied or imposed on the Bidder on account or payments received by it from CSL for the work done under this contract. It shall be the responsibility of the Bidder to submit to the concerned Indian authorities, the returns and all other concerned documents required for this purpose and to comply in all respects with the requirements of the laws in this regard, in time.</p>
9.	<p><u>Goods & Service Tax</u></p> <p>(a) Please note the CSL GST registered number as 32AAACC6905B1ZD. GST registration is prerequisite for entering into the business with CSL. Your firm's GST registration shall be indicated. Offers received from GST unregistered suppliers / service providers are liable for rejection.</p> <p>(b) Indicate the applicable rate of GST for services in line with Gol published rate scheduled for services along with SAC.</p> <p>(c) Tax inclusive invoices from the registered service providers are not acceptable. Any corrections / rectifications in the invoice shall be made good through Debit note / Credit note.</p> <p>(d) Bidders are advised to check applicable GST on their own before quoting. Buyer will not take any responsibility in this regards. GST reimbursement will be as per actuals or as per applicable rates (whichever is lower), subject to the maximum of quoted GST %.</p>
10.	<p><u>Input Tax Credit:</u></p> <p>(a) Bidders shall ensure timely delivery of services and submit the tax invoices to CSL as per the GST law. In case, GST input tax credit is delayed / denied to CSL due to non / delayed receipt of services and / or tax invoice or expiry of timeline prescribed in GST law for availing such ITC, or owing to the bidder not paying the taxes to the Government within prescribed time as per the law or any other reasons not attributable to CSL and solely attributable to the bidder, the GST amount charged to CSL, shall be recoverable from the bidder along with interest levied / liveable and any other penalties on CSL and the vendor shall indemnify against all costs to CSL, and consequences therefrom.</p>

- (b) In case bidder delays declaring particulars in respect of any invoice in the GST return required to be filed by such bidder, and GST credit availed by CSL is denied or reversed subsequently as per GST law, GST amount paid by CSL towards such ITC reversal as per GST law shall be recoverable from vendor / bidder along with interest levied / leviable on CSL and any other penalties on CSL and the bidder shall hold CSL indemnified against all cost and consequences there from.
- (c) Bidders shall submit the invoices as per the provisions of GST law. The bidder's invoice shall contain the HSN code / SAC and GSTIN number of the bidder and CSL as well along with other particulars. The GST charged (IGST / CGST + SGST / UTGST) shall be clearly indicated in the invoice.
- (d) In case any credit, refund or other benefit is denied or delayed to CSL due to any non-compliance of GST legislation such as failure to pay GST to the government (includes late filing of GST return) or due to non-furnishing or furnishing of incorrect or incomplete documents/ information by the bidder or service provider, the bidder or service provider would reimburse the loss to CSL or CSL may recover the same, but not limited to, the tax loss, interest and penalty. The Bidders should submit the copy of Latest GST Return filed statement/ form in GSTR-3B

11. **Earnest Money Deposit (EMD):**

- (a) Rs1,00,000 to be submitted through Demand Draft / Bank Guarantee as per CSL standard format. Copy of EMD shall be submitted along with Part I Techno-Commercial Bid and EMD shall be delivered to Tender inviting authority.
- (b) Firms having valid CSL registration for similar works with a financial limit equal to or more than the cost of the work are exempted from payment of EMD. All such firms who intend to avail EMD exemption shall invariably enclose a copy of their valid CSL registration certificate along with Techno-Commercial bid.
- (c) No pending bill adjustments towards EMD amount are permitted.
- (d) The EMD amounts of unsuccessful bidders will be returned after finalization of the order. EMD amount of successful bidder will be released after submission of PBG. Firms having valid SSI/NSIC/MSME registration are exempted from payment of EMD. All such firms shall invariably enclose copy of valid SSI/NSIC/MSME registration certificate to claim EMD exemption.
- (e) In case the offer validity is extended on mutual consensus, the validity of EMD shall be mutually extended.

EMD may be submitted in the form of Insurance Surety Bonds, Account Payee Demand draft, Fixed Deposit receipt or Banker's cheque or Bank Guarantee from any of the scheduled commercial banks or payment online in an acceptable form.

CSL Bank details are as follows:

Bank	State Bank of India
IFSC	SBIN0004062
Account No.	10319928321 of Cochin Shipyard Ltd.

	<p><u>Forfeiture of EMD:</u> The EMD shall be forfeited by bidder in the following events.</p> <ul style="list-style-type: none"> (a) If Bid is withdrawn during the validity period of any extension thereof duly agreed by the Bidder. (b) If Bid is varied or modified in a manner not acceptable to CSL during the validity period or any extension of the validity duly agreed by the Bidder. (c) If it is established that bidder has submitted forged documents / certificates / information towards fulfilment of any of the tender / contract conditions.
12.	<p><u>Security Deposit/ Warrantee Bank Guarantee:</u></p> <ul style="list-style-type: none"> (a) The successful bidder shall remit a security deposit of 3% of the total order value (excluding taxes, duties) in the form of demand draft drawn in favour of Cochin Shipyard Ltd towards the satisfactory performance of the contract, if an order is placed on them. Alternatively, a Bank Guarantee equivalent to above % of the total order value (excluding taxes, duties) as per CSL format from an International Bank as per approved list of banks available in CSL website (for overseas supplier) & Scheduled Indian bank for Indian supplier is to be submitted, if an order is placed towards satisfactory performance of the contract. (b) The Bank Guarantee /DD as above should be initially valid till completion of receipt of cargo at CSL Stores plus 90 days. Fixed Deposit Receipt (for equivalent amount of Security Deposit / WBG required as per tender) in lieu of bank guarantee is also acceptable. Fixed Deposit Receipt shall be in the name of Freight forwarder with lien marked in favour of Cochin Shipyard Limited, Kochi. (c) If the bidder is not agreeable to submission of SD/ warranty bank guarantee as per CSL general terms and conditions of enquiry, CSL reserves the right to reject the offer at our discretion or 3% of total order value (excluding taxes and duties) will be added to the quoted price for tender comparison/ evaluation purpose on case to case basis for arriving the lowest bid. (d) SD to be submitted within 07 days of receipt of order from yard. (e) Format of bank guarantee along with enquiry to be agreed, in general.
13.	<p><u>Vendors on Tender Holiday / Blacklisted Vendors</u></p> <ul style="list-style-type: none"> (a) The bidder should give self-certification that they have neither been Blacklisted nor have received any tender holiday from any PSUs/Central & State Govt. Organizations or any other Government / Quasi Government Organizations during last 03 (three) years ending on the date of submission of the Tender by the bidder. The bidder has to submit self certification for the same along with the techno-commercial offer. (b) CSL reserves the right to independently verify the same. In case violation of declaration is detected at any stage of tender process and during currency of contract, the order will be terminated/cancelled and EMD/SD shall be forfeited and appropriate action will be taken in accordance with the vendor policy of CSL.
14.	<ul style="list-style-type: none"> (a) No contract of any kind whatsoever shall be placed to debarred firm including allied firms after the issue of a debarment order by the Ministry/Department. (b) Bids from only such firms shall be considered for placement of contract, which are neither debarred on the date of opening of tender nor debarred

	<p>on the date on contract.</p> <p>(c) In case, any debarred firm has submitted the bid, the same shall be ignored.</p> <p>(d) The debarment shall be automatically extended to all its allied firms.</p> <p>(e) In case of JV/consortium is debarred all partners will also stand debarred for the period specified in the debarment order.</p>
15.	<p><u>Liquidated Damages:</u></p> <p>The forwarder shall receive the Cargo from Shipper premises at Vung Tau, Vietnam to the Stores of Cochin Shipyard Limited, Kochi, Kerala, on the date of item readiness as stipulated in the contract. In case of any delay incurred in</p> <p>i) Receipt of items from Shipper premises, from the date specified in the contract or ii) Delivery of cargo at CSL Stores</p> <p>Freight Forwarder is to pay Liquidated Damages (and not by way of penalty) a sum equivalent to ½% (half percent) per week or part of the week of the total basic price quoted, subject to a maximum of 10% of total basic Contract Value (Total basic price is the order value excluding taxes & other charges). However LD applicability is without prejudice to CSL right to terminate contract for delayed delivery or other actions as per clause 6 & 23 of GTC.</p> <p>For the purpose of Calculating/Imposing L.D, as per (ii) above, the delay shall be calculated from scheduled date of delivery of cargo at CSL Stores as per the delivery lead time stipulated in the contract.</p>
16.	<p><u>Jurisdiction</u></p> <p>All questions, disputes or difference arising under, out of, or in connection with contracts shall be subject to the exclusive jurisdiction of the Courts at Cochin, India. Alternate dispute resolution mechanism can also be considered.</p>
17.	<p><u>Arbitration</u></p> <p>(a) Any disputes arising during the period of the contract shall, in the first instance be settled by mutual discussions and negotiations. The results of such resolution of dispute shall be incorporated as an amendment to the contract, failing which supplier shall approach the CSL Grievance Redressal Cell as per relevant clause of the Contract.</p> <p>(b) If any dispute, disagreement or question arising out of or relating to or in consequence of the contract, or to its fulfillment, or the validity of enforcement thereof, cannot be settled mutually or the settlement of which is not herein specifically provided for, then the dispute shall within thirty days from the date either party informs the other in writing that such disputes, disagreement exists, be referred to arbitration. The arbitrators shall be appointed and the arbitration proceedings shall be conducted in accordance with and subject to the Arbitration and Conciliation Act, 1996 (No. 26 of 1996) as amended from time to time and the decision of the Arbitrators shall be final and binding on the parties hereto. The arbitration will be done by a Board comprising one arbitrators nominated by each party, and a mutually agreed Umpire. Each party shall bear its own cost of preparing and presenting its case. The cost of arbitration shall be shared</p>

	<p>equally by the parties unless the award provides otherwise. Performance under this Contract shall however, continue during arbitration proceedings and no payment due or payable by the parties hereto shall be withheld unless any such payment is or forms a part of the subject matter of arbitration proceedings.</p> <p>(c) Seat & Venue of Arbitration: The seat & venue of arbitration shall be at Cochin.</p> <p>(d) Language of Arbitration: The Language of arbitration shall be English. Governing Law: The contract shall be governed by Indian Law.</p> <p>(e) In case of disputes, the same will be subjected to the jurisdiction of courts at Cochin, Kerala</p>
18.	<p><u>Force Majeure condition:</u> Should failure in performance of the contract or part thereof arise from war insurrection, restraint imposed by Government, Act of Legislature or other Statutory Authority or illegal strike, riot, legal lock-out, flood, fire, explosion, act of God or any inevitable or unforeseen event beyond human control which may be construed as reasonable ground for an extension of time, CSL/ Supplier may allow such additional time as is mutually agreed, to be justified by the circumstances of the case. The occurrence/cessation of force majeure situation is to be informed with documentary evidence within 15 days from the date of occurrence/ cessation.</p>
19.	<p><u>Indian Agent:</u></p> <p>(a) Cochin Shipyard Ltd, prefers to deal directly with the supplier. However, if the supplier appoints an Indian Agent to deal with Cochin Shipyard Ltd., the Agency commission payable by the supplier to such an agency shall be intimated.</p> <p>(b) If manufacturers effect the supply through Agents only, authorization in writing from manufacturers in favour of the Agent for supply to CSL shall be furnished.</p> <p>(c) In a tender, either the Indian agent on behalf of the Principal or Principal itself can bid but both cannot bid simultaneously for the same item/ product in the same tender. If an agent submits bid on behalf of principal/OEM, the same agent shall not submit a bid on behalf of another principal in the same tender for the same item. Indian agents cannot represent more than one firm or quote on their behalf for any particular tender.</p>
20.	<p><u>Sub Contracting And Assignment</u> Supplier shall not contract with any subcontractor and/or vendor without the prior written consent of CSL. Such consent shall not relieve the Supplier from any of his responsibilities and liabilities under the Purchase Order. In addition, Supplier shall ensure that the terms and conditions of any such contract shall comply with and correspond to the terms and conditions of the Purchase Order.</p>
21.	<p><u>Supply</u></p> <p>(a) Quoted prices shall be inclusive of the entire scope of the contract as provided at Annexure "A" of the Tender Enquiry</p> <p>(b) The subject goods as per details mentioned in Annexure "E" Shall be insured by CSL. The forwarder shall provide all details such as the type and details of vehicle used for local transportation at the country of exportation and shipment details such as Bill of Lading, weight, dimensions of cargo. Notwithstanding any omissions herein, all details required for arranging Insurance shall be forwarded prior to shipment. The</p>

	<p>forwarder shall be responsible for all the financial and legal consequences arising due to lapse on their part in furnishing the information timely. Only the goods shall be covered by CSL insurance and CSL shall not be responsible for arranging insurance for personnel or other movables and shall be absolved from any financial or legal liabilities arising due to non-compliance thereof.</p> <p>(c) Marine Warranty Survey, if required, shall be to Forwarder scope and prices shall be inclusive of the same</p> <p>The Freight Forwarder shall be liable to pay Emission Trading Surcharge (ETS) as per EU Rules and Guidelines applicable from 01.01.2024</p>
22.	<p>Upon placement of order (by post or mail) the supplier shall submit the acknowledgement (ie: signed and stamped original/ scanned soft copy by mail) as a token of acceptance of order within 07 days. In case CSL doesn't receive the above, it will be deemed as accepted.</p>
23.	<p><u>Termination Clause</u></p> <p>(a) This purchase order may be terminated upon the occurrence of any of the following events</p> <ul style="list-style-type: none"> (i) By agreement in writing of the parties hereto; (ii) By the non-defaulting party, upon default by the other party, of any clause of this contract, if not remedied within thirty (30) days, or such longer time as may be agreed upon by the parties, after receipt of notice thereof in writing from the non-defaulting party; (iii) By the other party, upon either parties; <ul style="list-style-type: none"> • Making the assignment for the benefit of creditors, being adjudged bankrupt or becoming insolvent; or • Having a reasonable petition filed seeking its' dissolution or liquidation, not stayed or dismissed within sixty (60) days; or • Ceasing to do business for any reason. (iv) In cases where maximum limit of LD is reached and still the items are not delivered. (v) For fraud and corruption or other unacceptable practices. <p>(b) Upon expiry or termination of this Contract, neither party shall be discharged from any antecedent obligations or liabilities to the other party under this Contract unless otherwise agreed in writing.</p> <p>(c) CSL may by notice in writing to supplier terminate the order after issuing due notice i.e. 15 days notice period. CSL shall be entitled to compensation for the loss limited to the order value.</p> <p>(d) Liability maximum that can be claimed by the supplier shall be limited to what is due to be and has been paid by CSL for the material delivered/work done as per the payment milestones.</p>
24.	<p><u>Limitations of Liability</u></p> <p>Neither party shall be liable to the other party for any indirect and consequential damages. Neither party shall be liable to the other party for any loss of profits or loss of production</p>

25.	<p><u>Confidentiality Clause</u> Supplier and its personnel will</p> <p>(a) keep confidential the terms of the agreement and all non-public and proprietary CSL information, and will only use such information to provide products and services under the agreement, and will not disclose such information except to the extent required by law after giving reasonable notice to CSL, if permitted by law; and</p> <p>(b) not use in providing products or services or disclose to CSL any materials or documents of another party considered confidential or proprietary unless it has obtained written authorization from that party and CSL</p>
26.	<p><u>Indemnity clause</u> Supplier will indemnify CSL and its affiliates, directors, officers, and employees against all liabilities, damages, losses, costs, fees (including legal fees), and expenses relating to any allegation or third-party legal proceeding (including action by a government authority) to the extent arising from an allegation that use, possession, or sale of the products or services violates or infringes a third party's rights, including intellectual property rights; or an allegation that any personnel are entitled to employee compensation, benefits, or other rights or transfer law rights, except to the extent caused by CSL's unlawful acts or omissions.</p>
27	<p><u>Malicious Code:</u> The Bidder will be overall responsible for all cyber/information security related aspects pertaining to the Systems Projects & ICT goods and services and will be the single point of contact for addressing all Cyber/information security related issues for the goods and services supplied by the Bidder as part of the contract. It will be responsibility of the Bidder to enter into such agreements/contracts with the OEMs as may be necessary to ensure that all cyber/information security aspects are addressed holistically and comprehensively. The Bidder will provide list of tests conducted by OEM or an accredited certification agency along with list of such test reports for the Systems Projects & ICT goods and services provided as part of contract.</p>
28	<p>(a) Integrity Pact - As per Government of India (Central Vigilance Commission), CSL and the SUPPLIER have to sign an Integrity Pact for the high value contracts, for ensuring transparency, equity and competitiveness in public procurement. The Tenderer has to sign Pre-Contract Integrity Pact as per format enclosed and to submit along with offer. The above is applicable when the total basic price is above Rs. 100.0 lakhs.</p> <p>(b) For offers less than the threshold value of INR 100.00 lakh, Code of Integrity in Public Procurement (CIPP) and Code of Conduct for suppliers is to be signed and submitted along with the offer.</p>
29	<p>Restriction on Procurement from Countries Sharing Land Border with India</p> <p>(a) Any bidder from a country which shares a land border with India will be eligible to bid only if the bidder is registered with the Competent Authority, specified below.</p> <p>(b) A bidder is permitted to procure raw material, components, sub-assemblies etc, from vendors from countries sharing land border with India. Such vendors will not be required to be registered with competent authority.</p>

(c) However, in case the bidder has proposed to supply finished product from vendors from countries sharing land border with India, such vendors will be required to be registered with competent authority.

(d) Definitions

(i) "Bidder" for the purpose of the Order (including the term 'tenderer', 'consultant' 'vendor' or 'service provider' in certain contexts) means any person or firm or company, including any member of a consortium or joint venture (that is an association of several persons, or firms or companies), every artificial juridical person not falling in any of the descriptions of bidders stated hereinbefore, including any agency, branch or office controlled by such person, participating in a procurement process.

(ii) "Tender" for the purpose of the Order will include other forms of procurement, except where the context requires otherwise.

(iii) "Bidder from a country which shares a land border with India" for the purpose of the Order means

- An entity incorporated, established or registered in such a country; or
- A subsidiary of an entity incorporated, established or registered in such a country; or
- An entity substantially controlled through entities incorporated, established or registered in such a country; or
- An entity whose beneficial owner is situated in such a country; or
- An Indian (or other) agent of such an entity; or
- A natural person who is a citizen of such a country; or
- A consortium or joint venture where any member of the consortium or joint venture falls under any of the above

(iv) "Agent" for the purpose of the Order is a person employed to do any act for another, or to represent another in dealings with third persons.

(v) Beneficial owner for the purposes of point (iii) above will be as under:

- In case of a company or Limited Liability Partnership, the beneficial owner is the natural person(s), who, whether acting alone or together, or through one or more juridical person(s), has a controlling ownership interest or who exercises control through other means. Explanation:-
- In case of a partnership firm, the beneficial owner is the natural person(s) who, whether acting alone or together, or through one or more juridical person, has ownership of entitlement to more than fifteen percent of capital or profits of the partnership;
- In case of an unincorporated association or body of individuals, the beneficial owner is the natural person(s), who, whether acting alone or together, or through one or more juridical person, has ownership of or entitlement to more than fifteen percent of the property or capital or profits of such association or body of individuals;
- Where no natural person is identified under para (iii) above, the beneficial owner is the relevant natural person who

	<p>holds the position of senior managing official;</p> <ul style="list-style-type: none"> In case of a trust, the identification of beneficial owner(s) shall include identification of the author of the trust, the trustee, the beneficiaries with fifteen percent or more interest in the trust and any other natural person exercising ultimate effective control over the trust through a chain of control or ownership. <p>(e) Wordings of certificate to be submitted along with tender documents:- “I have read the clause regarding restrictions on procurement from a bidder of a country which shares a land border with India. I hereby certify that this bidder is not from such a country or, if from such a country, has been registered with the competent authority. I hereby certify that this bidder fulfils all requirements in this regard and is eligible to be considered. (Evidence of valid registration by the competent authority shall be attached wherever applicable).”</p> <p>Further, I will not subcontract any work to a contractor / source finished goods from an entity from such countries unless such contractor/ entity is registered with the competent authority. I hereby certify that this bidder fulfils all requirements in this regard and is eligible to be considered (Evidence of valid registration by the competent authority shall be attached wherever applicable).”</p>
30	<p>Purchase Preference for MSEs</p> <p>(a) Participating Micro and Small Enterprises (MSE) quoting price within price band of L1+15 (fifteen) per cent be offered option to supply the entire quantity, subject to meeting L1 price.</p> <p>(b) In case of tender item cannot be split or divided, etc. the MSE quoting a price within L1+15% may be awarded for full/ complete supply of total tendered value to MSE, considering the spirit of the Policy for enhancing Govt. Procurement from MSEs.</p>
31	<p>Purchase Preference for Make In India (MII)</p> <p>(a) To encourage ‘Make in India’ and promote manufacturing and production of goods and services in India with a view to enhancing income and employment, Department of Promotion of Industry and Internal Trade (DPIIT), Ministry of Commerce and Industry, Government of India, issued Public Procurement (Preference to Make in India), Order 2017. The order is issued pursuant to Rule 153 (iii) of GFR, 2017. The Order is applicable on the procurement of Goods, Works and Services. For the purpose of this Order:-</p> <p>(b) Eligibility of ‘Class-I local supplier’/ ‘Class-II local supplier’/ ‘Non-local suppliers’ for different types of procurement</p> <p>(i) In procurement of all goods, services or works in respect of which the Nodal Ministry/ Department has communicated that there is sufficient local capacity and local competition, only ‘Class-I local supplier’, shall be eligible to bid irrespective of purchase value.</p> <p>(ii) Only ‘Class-I local supplier’ and ‘Class-II local supplier’, shall be eligible to bid in procurements undertaken by procuring entities, except when Global tender enquiry has been issued. In global tender enquiries, ‘Non-local suppliers’ shall also be eligible to bid along with ‘Class-I local suppliers’ and ‘Class-II local suppliers’.</p>

(c) **Purchase Preference**

A. In the procurements of goods or works which are divisible in nature, the 'Class-I local supplier' shall get purchase preference over 'Class-II local supplier' as well as 'Non-local supplier', as per following procedure:-

- (i) Among all qualified bids, the lowest bid will be termed as L1. If L1 is 'Class-I local supplier', the contract for full quantity will be awarded to L1.
- (ii) If L1 bid is not a 'Class-I local supplier', 50 (fifty) percent of the order quantity shall be awarded to L1. Thereafter, the lowest bidder among the 'Class-I local supplier' will be invited to match the L1 price for the remaining 50 (fifty) percent quantity subject to the Class-I local supplier's quoted price falling within the margin of purchase preference, and contract for that quantity shall be awarded to such 'Class-I local supplier' subject to matching the L1 price. In case such lowest eligible 'Class-I local supplier' fails to match the L1 price or accepts less than the offered quantity, the next higher 'Class-I local supplier' within the margin of purchase preference shall be invited to match the L1 price for remaining quantity and so on, and contract shall be awarded accordingly. In case some quantity is still left uncovered on Class-I local suppliers, then such balance quantity may also be ordered on the L1 bidder.

B. In the procurements of goods or works which are not divisible in nature, and in procurement of services where the bid is evaluated on price alone, the 'Class-I local supplier' shall get purchase preference over 'Class-II local supplier' as well as 'Non-local supplier', as per following procedure:-

- (i) Among all qualified bids, the lowest bid will be termed as L1. If L1 is 'Class-I local supplier', the contract will be awarded to L1.
- (ii) If L1 is not 'Class-I local supplier', the lowest bidder among the 'Class-I local supplier', will be invited to match the L1 price subject to Class-I local supplier's quoted price falling within the margin of purchase preference, and the contract shall be awarded to such 'Class-I local supplier' subject to matching the L1 price.
- (iii) In case such lowest eligible 'Class-I local supplier' fails to match the L1 price, the 'Class-I local supplier' with the next higher bid within the margin of purchase preference shall be invited to match the L1 price and so on and contract shall be awarded accordingly. In case none of the 'Class-I local supplier' within the margin of purchase preference matches the L1 price, the contract may be awarded to the L1 bidder.
- (iv) "Class-II local supplier" will not get purchase preference in any procurement, undertaken by procuring entities.

C. Applicability in tenders where contract is to be awarded to multiple bidders
In tenders where contract is awarded to multiple bidders subject to matching of L1 rates or otherwise, the 'Class-I local supplier' shall get purchase preference over 'Class-II local supplier' as well as 'Non-local supplier', as per following procedure:

- (i) In case there is sufficient local capacity and competition for the item to be procured, as notified by the nodal Ministry, only Class I

local suppliers shall be eligible to bid. As such, the multiple suppliers, who would be awarded the contract, should be all and only 'Class I Local suppliers'.

- (ii) In other cases, 'Class II local suppliers' and 'Non local suppliers' may also participate in the bidding process along with 'Class I Local suppliers' as per provisions of the Order.
- (iii) If 'Class I Local suppliers' qualify for award of contract for at least 50 (fifty) percent of the tendered quantity in any tender, the contract may be awarded to all the qualified bidders as per award criteria stipulated in the bid documents. However, in case 'Class I Local suppliers' do not qualify for award of contract for at least 50 (fifty) percent of the tendered quantity, purchase preference should be given to the 'Class I local supplier' over 'Class II local suppliers'/ 'Non local suppliers' provided that their quoted rate falls within 20 (twenty) percent margin of purchase preference of the highest quoted bidder considered for award of contract so as to ensure that the 'Class I Local suppliers' taken in totality are considered for award of contract for at least 50 (fifty) percent of the tendered quantity.
- (iv) First purchase preference has to be given to the lowest quoting 'Class-I local supplier', whose quoted rates fall within 20 (twenty) percent margin of purchase preference, subject to its meeting the prescribed criteria for award of contract as also the constraint of maximum quantity that can be sourced from any single supplier. If the lowest quoting 'Class-I local supplier', does not qualify for purchase preference because of aforesaid constraints or does not accept the offered quantity, an opportunity may be given to next higher 'Class-I local supplier', falling within 20 (twenty) percent margin of purchase preference, and so on.

D. Minimum local content: The 'local content' requirement to categorize a supplier as 'Class-I local supplier' is minimum 50 (fifty) percent. For 'Class-II local supplier', the 'local content' requirement is minimum 20 (twenty) percent. Nodal Ministry/ Department may prescribe only a higher percentage of minimum local content requirement to categorize a supplier as 'Class-I local supplier'/ 'Class-II local supplier'. For the items, for which Nodal Ministry/ Department has not prescribed higher minimum local content notification under the Order, it shall be 50 (fifty) percent and 20 (twenty) percent for 'Class-I local supplier'/ 'Class-II local supplier' respectively.

E. Requirement for specification in advance: The minimum local content, the margin of purchase preference and the procedure for preference to Make in India shall be specified in the notice inviting tenders or other form of procurement solicitation and shall not be varied during a particular procurement transaction.

F. Verification of local content:

- (i) The 'Class-I local supplier'/ 'Class-II local supplier' at the time of tender, bidding or solicitation shall be required to indicate percentage of local content and provide self- certification that the item offered meets the local content requirement for 'Class-I local supplier'/ 'Class-II local supplier', as the case may be. They shall

	<p>also give details of the location(s) at which the local value addition is made.</p> <p>(ii) In cases of procurement for a value in excess of Rs. 10 crores, the 'Class-I local supplier'/ 'Class-II local supplier' shall be required to provide a certificate from the statutory auditor or cost auditor of the company (in the case of companies) or from a practicing cost accountant or practicing chartered accountant (in respect of suppliers other than companies) giving the percentage of local content.</p> <p>(iii) False declarations will be in breach of the Code of Integrity under Rule 175(1)(i)(h) of the General Financial Rules for which a bidder or its successors can be debarred for up to two years as per Rule 151 (iii) of the General Financial Rules along with such other actions as may be permissible under law. A supplier who has been debarred by any procuring entity for violation of the Order shall not be eligible for preference under the Order for procurement by any other procuring entity for the duration of the debarment. The debarment for such other procuring entities shall take effect prospectively from the date on which it comes to the notice of other procurement entities.</p>
--	---

Special Conditions of Contract

The following are the Special Conditions of Contract. This shall be read in conjunction with the Conditions of Contract and bidders shall strictly comply to all the Special Terms and Conditions mentioned herein

1. Freight forwarder shall be registered with Director General of Shipping under Multimodal Transport operator Rules, 1992.
2. The Freight forwarder shall hold a valid CHA license in his own name issued by the Commissioner of Customs under relevant provisions of Customs act, 1962 read with Customs House Agent act, 1984. OR The Freight forwarder shall have an agreement with a clearing agent for clearance who holds a valid CHA license issued by the Commissioner of Customs under relevant provisions of Customs act, 1962 read with Customs House Agent act, 1984.
3. All statutory requisites mandated by the Government of India as per provisions of The (Indian) Bills of Lading Act, 1856; The Carriage of Goods by Sea Act, 1925; The Merchant Shipping Act, 1958; The Marine Insurance Act, 1963, The Warehousing (Development and Regulation) Act, 2007 and any other regulations/act/rules issued by Government of India and amendments thereto shall be fulfilled by the Freight forwarder
4. The Freight Forwarder has to arrange Export Clearance/Licensing formalities and other statutory compliances at the Port of Dispatch and Intermediate Port (if any)

5. The Freight forwarder shall adhere to guidelines laid out in the Union Code of Customs, 2016 and relevant regulation of the European Parliament pertaining to Exports. However, in cases where UCC Transitional Delegated Act is applicable, the same shall be complied to. CSL shall not be responsible for any non-compliance on the part of the Freight Forwarder
6. The Freight forwarder shall adhere to extant rules and regulations on Inland Waterways applicable in the relevant country
7. The Freight forwarder shall ensure that all rules, regulations, Standards and Guidelines applicable as per International Convention for the Safety of Life at Sea, 1974, International Convention for the Prevention of Pollution from Ships, 1973/1978, Convention on the International Regulations for Preventing Collisions at Sea, 1972, International Convention on Loadlines, 1966, The International Ship and Port Facility Security Code, 2002, The International Safety Management Code, 1993, (International Convention on Standards of Training, Certification and Watchkeeping for Seafarers, 1978/1995/2010 and International Labour Convention, 2013 among others are strictly complied to. The list is not exhaustive and it shall be the sole responsibility of the Freight forwarder to ensure mandatory compliance to all extant Rules, Regulations, Standards and Guidelines applicable in International Shipping
8. The Freight Forwarder shall ensure compliance to Merchant Ships Act, 1958 and Multimodal Transport of Goods Act, 1993 among others. The list is not exhaustive and it shall be the sole responsibility of the Freight forwarder to ensure mandatory compliance to all extant Shipping Rules, Regulations, Standards and Guidelines applicable in India
9. The Freight forwarder shall be responsible for Customs clearance/formalities at Cochin Port and is included in the scope of the contract
10. The Freight forwarder has to arrange Port permission/ tug or Boat assistance / clearance /formalities at Cochin, destination points and intermediate ports, if required (fortotal transportation) including pilotage.
11. The Freight forwarder shall ensure to compliance of labour laws as applicable in India and in relevant country with regards to the personnel employed. CSL shall be absolved of all legal and economic consequences of Non-compliance to requisite labour Laws and Standards.
12. Notwithstanding any omissions herein, the Freight Forwarder shall be responsible for compliance to all rules, regulations and standards applicable to the firm and it's personnel. CSL shall not be responsible for any breach on the part of the Freight Forwarder, Shipping Company or any other party. CSL shall not be liable to pay compensation or be subject to any penal action for any violations not attributable directly to CSL

TENDER DECLARATION

This is to certify that I have completely read and understood the tender enquiry / GeM bid numberand we M/s..... hereby declare that will abide by all the tender conditions . Deviations, if any in the techno-commercial offer from that of the tender enquiry and subsequent corrigendum in any form will be clearly furnished by us in a separate document which will be titled as “List of Deviations”.

If we are not providing any separate document titled as “List of Deviations” then it is to be considered that all the terms and conditions are acceptable to us.

Sign and stamp

Declaration in Lieu of EMD/ Bid security (if applicable)

I / We, the authorized signatory of
M/s....., participating in the
subject Tender Enquiry / GEM Bid No. for
the item / job of, do hereby declare:

i. That I / We have availed the benefit of waiver of EMD while submitting our offer against the subject subject Tender Enquiry / GEM Bid and no EMD being deposited for the said tender.

ii. That in the event we withdraw / modify our bid during the period of validity Or I/We fail to execute formal contract agreement within the given timeline OR I/We fail to submit a Performance Security within the given timeline Or I/we commit any breach of Tender Conditions / Contract which attracts penal action of forfeiture of EMD and I/we will be suspended from being eligible for bidding / award of all future contract(s) of Cochin Shipyard Ltd. for a period ofmonths.. from the date of committing such breach.

Signature and Seal of Authorized Signatory of bidder

Name of Authorized Signatory.....
Company Name.....

PRICE BID FORMAT

Sl. No.	DESCRIPTION	Unit	Total Rate (INR)
1	Transportation of Cargo at Annexure 'E' from works of M/s Uptime, at Vung Tau, Vietnam on Ex-works basis to the Stores of Cochin Shipyard Limited (First ship set – Ex-works pick up date 10.03.2025)	Lumpsum	
2	Transportation of Cargo at Annexure 'E' from works of M/s Uptime at Vung Tau, Vietnam on Ex-works basis to the Stores of Cochin Shipyard Limited (Second ship set – Ex-works pick up date 21.04.2025)	Lumpsum	
3	TOTAL BASIC PRICE	<u>Figures:-</u> _____ <u>In Words:-</u> _____ _____	
4	Other charge (if any)		
5	Taxes (if any)		
6	TOTAL PRICE (Sl. 3+4+5)	<u>Figures:-</u> _____ <u>In Words:-</u> _____ _____	

Note:-

a) Unpriced price bid format (which is an exact replica of the Price bid except that Price is blanked) as per annexure 'C' to be submitted along with techno commercial bid with details like percentage of taxes & duties applicable and stating "Quoted" or "Not Quoted" or "Not Applicable" or "By CSL" to be mentioned for each line item.

b) The quoted price shall be inclusive of all operations listed at of the Scope of Work (Annexure 'A').

d) No additional claim shall be admitted for the given scope. The bidder is responsible for the assessment of the cargo and for arranging necessary transportation in line with the scope of work. The volume of cargo mentioned in the scope of work document is indicative and any variation in weight /volume within +/- 5 % shall be considered without any additional cost to CSL.

Signature :

Name & Address of the firm :

Qualification Criteria

The bidders shall mandatorily meet the following Qualification criteria, failing upon which the bids may be summarily rejected

A) Experience and Past Performance

The bidder should have, in the past 5 financial years (From FY 2019-20 to FY 2023-24) undertaken atleast 3 (Three) Works of transporting Break-bulk cargo of similar volume to the consignment of subject tender, on Ex-works factory basis from any port outside India to a Major Indian port (Refer the Scope of work at Annexure 'A')

Major Indian port means ports listed as per Major Port Authorities Act, 2021.

B) Financial Standing

1. The average financial turnover of 'The bidder' during the last 3 financial years (hereinafter called the relevant period), ending on 31.03.2024 or the Financial Year ending date of equivalent period in other countries (hereinafter called the relevant date) should be atleast INR 02Crore (or Equivalent in Foreign currency at exchange rate prevalent on the relevant date) as per the annual Audited Balance sheet and P&L account of the relevant period, duly authenticated by a Chartered accountant or cost accountant in India or equivalent in relevant countries

2. The bidder firm shall have an average EBITDA of atleast INR 40 lakhs during the relevant period (or Equivalent in Foreign currency at exchange rate prevalent on the relevant date) as per the annual Audited Balance sheet and Profit & Loss account, duly authenticated by a Chartered accountant or cost accountant in India or equivalent in relevant countries

Financial Standing credential of partners of Consortium/Joint Ventures cannot be clubbed for the purpose of compliance of PQC and shall meet the criteria separately. If the bidder qualifies in lieu of the financial standing of the Holding Company, the bidder shall produce a Corporate Guarantee from the Holding Company

C) Statutory and Regulatory requirements

1. The bidder shall be registered with Director General of Shipping under Multimodal Transport operator Rules, 1992.

2. The bidder shall hold a valid CHA license in his own name issued by the Commissioner of Customs under relevant provisions of Customs act, 1962 read with Customs House Agent act, 1984. OR The bidder shall have an agreement with a clearing agent for clearance who holds a valid CHA license issued by the Commissioner of Customs under relevant provisions of Customs act, 1962 read with Customs House Agent act, 1984.

3. All statutory requisites mandated by the Government of India as per provisions of The (Indian) Bills of Lading Act, 1856; The Carriage of Goods by Sea Act, 1925; The Merchant Shipping Act, 1958; The Marine Insurance Act, 1963, The Warehousing (Development and Regulation) Act, 2007 and any other regulations/act/rules issued by Government of India and amendments thereto shall be fulfilled by the bidders.

4. Restrictions under rule 144(xi) of GFR, 2017 on procurement of goods, services and works from bidders from countries sharing land border with India shall be applicable to the bidder and all consortium members/JV's and Holding Company.

5. The bidder shall not have been debarred /Blacklisted /Issued tender holiday by any Ministry/Department/Undertaking/Autonomous Body under Government of India at the time of submission of bid. The bidder has to provide an undertaking in it's letterhead in this regard, failing upon which the offer shall be rejected.

D) Documents to be submitted along with the Techno-commercial offer

i) To prove the necessary experience as per (A) above, following documents shall be submitted

- a) Copy of Order/Contract for awarding service including copy of invoice mentioning cargo value.
- b) Work completion certificate for the scope of supply indicated in the experience proof duly certified by the authority competent to do the same.

ii) The following documents shall be submitted to prove compliance to Financial Standing Credentials

- a) Annual Audited Balance sheet and P&L account of the relevant period, duly authenticated by a Chartered accountant or cost accountant in India or equivalent in relevant countries.
- b) The bidder shall provide details including the Name of the Bidder, Complete address of the bidder and the Contact Details. Offers submitted without the above details shall be summarily rejected.

The above documents shall be certified by Chartered accountant/Cost accountants registered under ICAI or equivalent. The same shall be verified by CSL prior to qualifying bidders

iii) The following documents shall be submitted to prove compliance to Statutory and Regulatory requirements

- a) Proof of registration with Director General of Shipping under Multimodal Transport operator Rules, 1992.
- b) Valid license in bidder's name or in the name of the entity issued by the Commissioner of Customs under relevant provisions of Customs act, 1962 read with Customs House Agent act, 1984 OR Copy of agreement with a clearing agent for clearance who holds a valid CHA license issued by the Commissioner of Customs under relevant provisions of Customs act, 1962 read with Customs House Agent act, 1984.
- c) Undertaking on compliance to Restrictions under rule 144(xi) of GFR, 2017 on procurement of goods, services and works from bidders from countries sharing land border with India in letter head of the bidder/All Consortium members in case of Consortium bid. (Refer the format placed at Annexure B

iv) Proof of Registration/Incorporation

The bidder shall furnish the Certificate of Incorporation (CIN), GST Registration Certificate, PAN and TAN

No.	Description	Country of origin	Unit	Q'ty	Weight (kg)	Weight (kg)	Dim. (mm)	Drawings No:
					Gross	Net		
					102644	1,00,544	Length x Width x High	
I	TOWER	Vietnam	SET	1	70143	69843	29163mm x 5550mm x 5090mm	2320000-UI-4020-N-XD-710-5011 2320000-UI-4020-N-XG-710-5010
II	CURSOR	Vietnam	SET	1	16199	15899	10020mm x 5500mm x 3150mm	2320000-UI-4020-N-XD-830-0015 2320000-UI-4020-N-XD-830-0017
III	HINGE AND HORIZONTAL E-CHAIN BOX	Vietnam	SET	1	8199	7899	6200mm x 4983mm x 4300mm	2320000-UI-4020-N-XD-830-5013 2320000-UI-4020-N-XD-830-5011
IV	SHEAVE SUPPORT JOKE	Vietnam	SET	1	2634	2334	6000mm x 650mm x 1100mm	2320000-UI-4020-N-XG-710-5501
V	WINCH PLATFORM AND HANDRAIL, LADDER	Vietnam	SET	1	2459	2159	6870mm x 3150mm x 2150mm	2320000-UI-4020-N-XG-710-5711
VI	PLATFORM HANDRAIL AND LADDER	Vietnam	SET	1	2100	1800	6400mm x 2000mm x 1550mm	2320000-UI-4020-N-XG-831-4001
VII	TUNNEL AND ACCESSORY	Vietnam	SET	1	910	610	3800mm x 1600mm x 1700mm	NA
VIII	40" Container with loose items	Vietnam	PC	1	TBA	TBA		NA

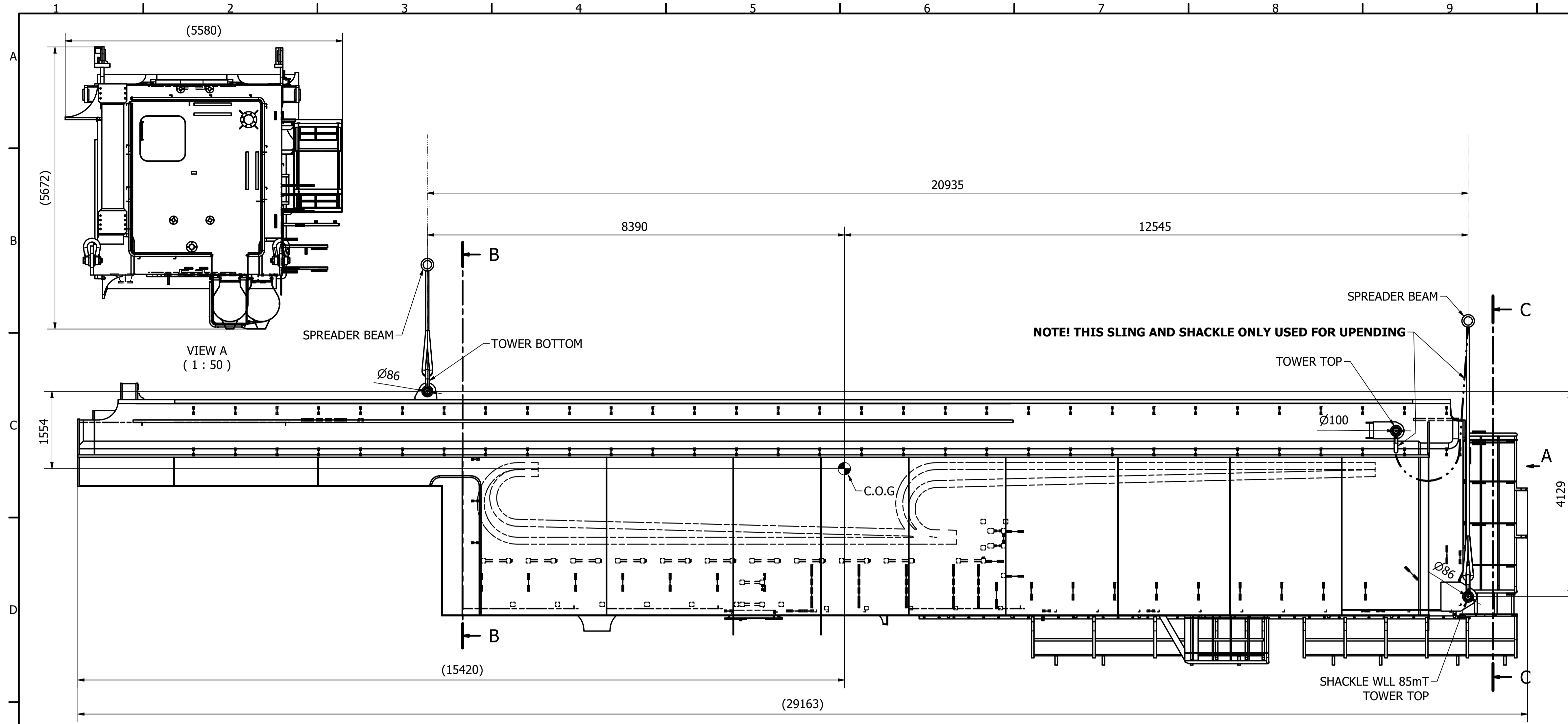

- NOTES:
1. THIS DRAWING SHOWS DETAILS REGARDING LIFTING THE TOWER IN HORIZONTAL POSITION ONLY.
 2. ALL RIGGING ITEMS TO BE SUPPLIED BY LIFTING CONTRACTOR.
 3. RIGGING BASED ON LIFTING WITH 2 CRANES.
 4. MBL BASED ON SF OF 2.8.
 5. ALL RIGGING CAPACITIES BASED ON STEEL WIRE ROPE.

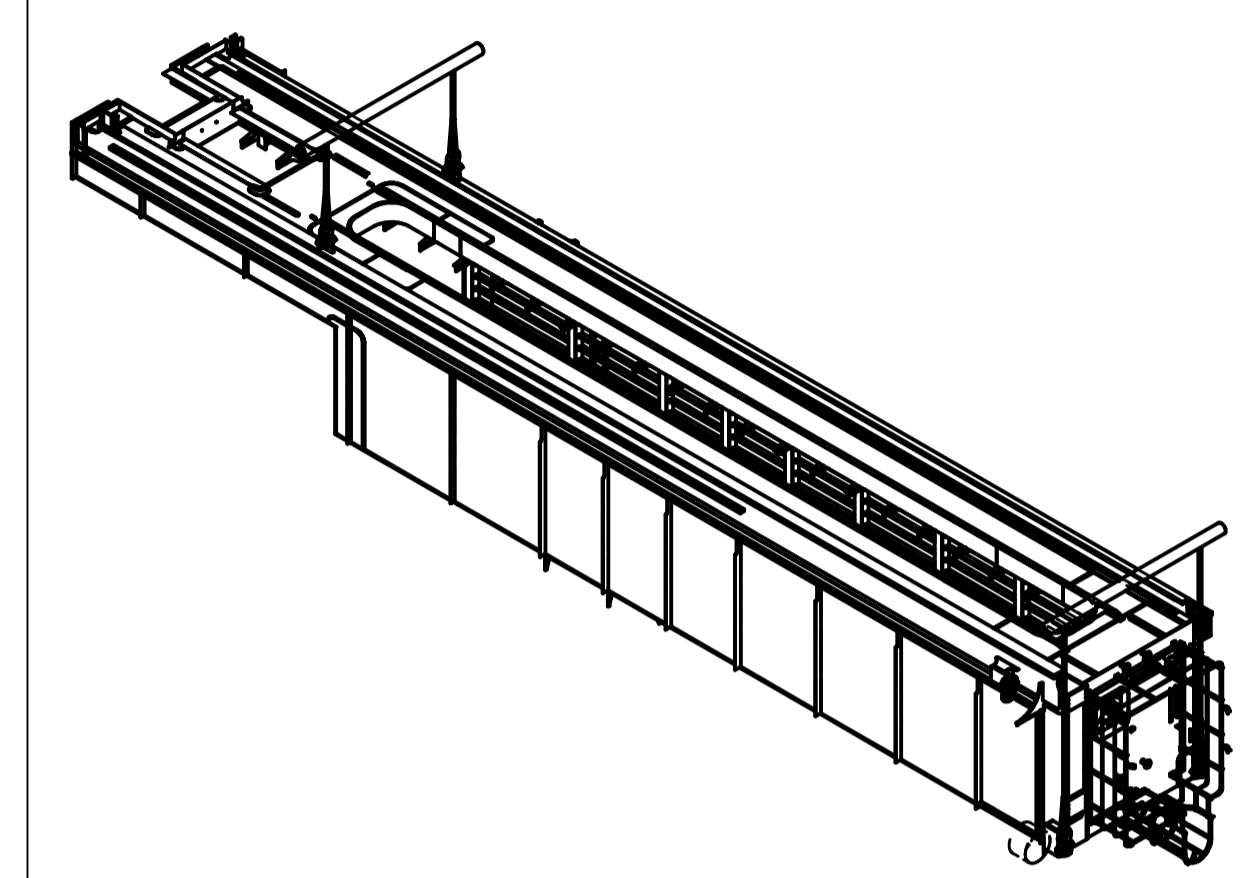

ISO VIEW
(1 : 150)

Total weight: 79771 kg

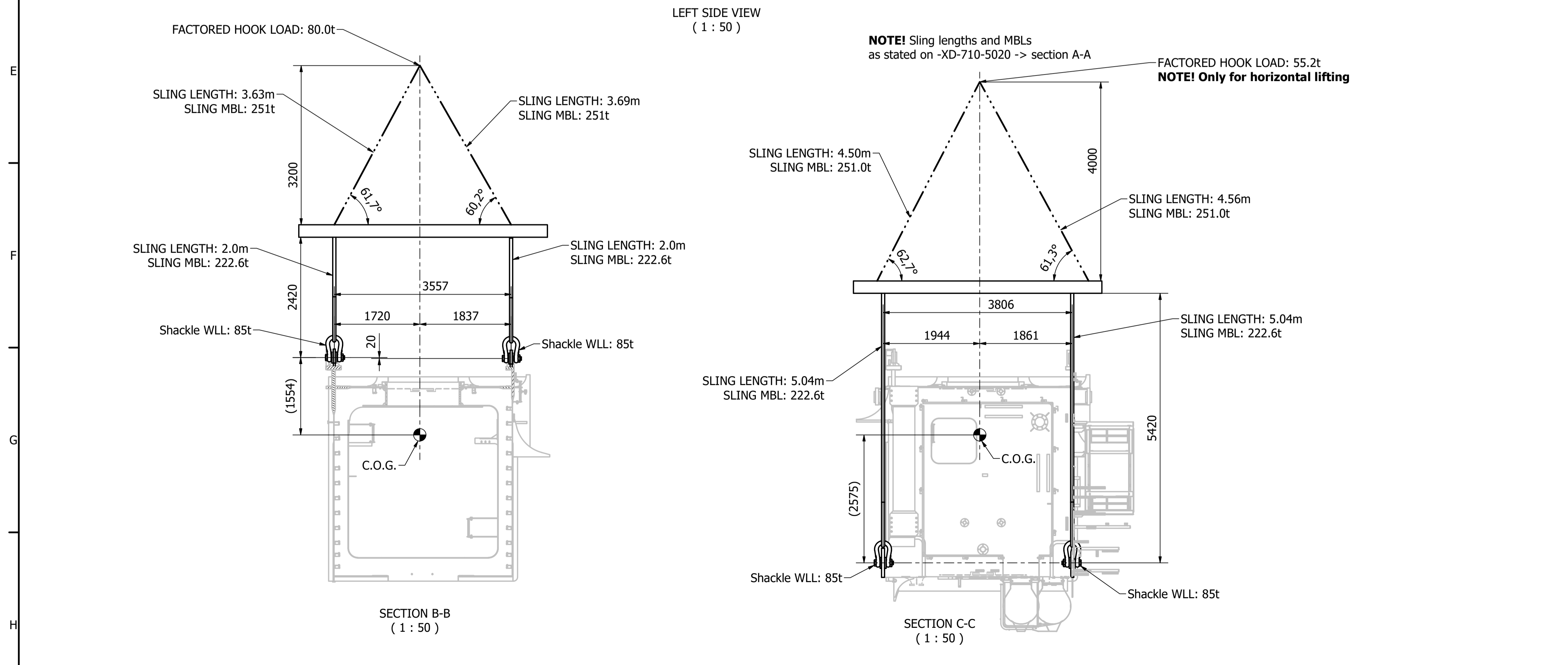

REV	DATE	DESCRIPTION	PREPARED	CHECKED	DIS.CHECK	APPROVED
01	04-12-2024	Issued For Information	DBa	TTW	FG	FD

Proprietary Rights, Intellectual Property and Confidentiality Notice.
Copyright 2021 UPTIME International AS. All right reserved.
This document contains and is intended to convey confidential and proprietary information which is the exclusive intellectual property of UPTIME International AS. This document, in electronic or hard copy format and any attachments included with or reference therein, MAY NOT by any means be reproduced, duplicated, distributed, shared, disclosed or used for any purpose without the express written permission of UPTIME International AS.

	PROJECT VESSEL DESIGN/ ID :
	BY151
	CLIENT
	Cochin Shipyards Ltd.

Project:	2320000 - Uptime 148	ALL DIMENSIONS	IN mm U.N.O
Title:	TELESCOPIC GANGWAY 30m 3.0 ELECTRIC STEEL ELEVATOR TOWER TOWER HORIZONTAL LIFTING - SHEET 1		
Drawing No:	2320000-UI-4020-N-XD-710-5011	Vault Ref:	710-5011
Rev. No:	01	Sub. No:	Sheet

START POSITION UPENDING/HORIZONTAL LIFTING

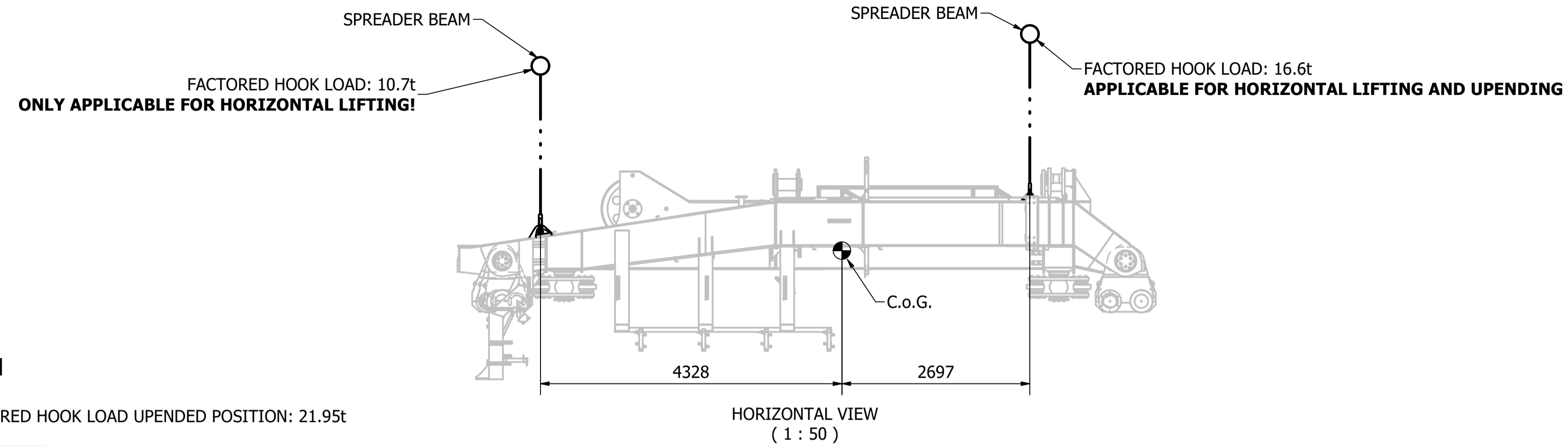

SLING INFORMATION

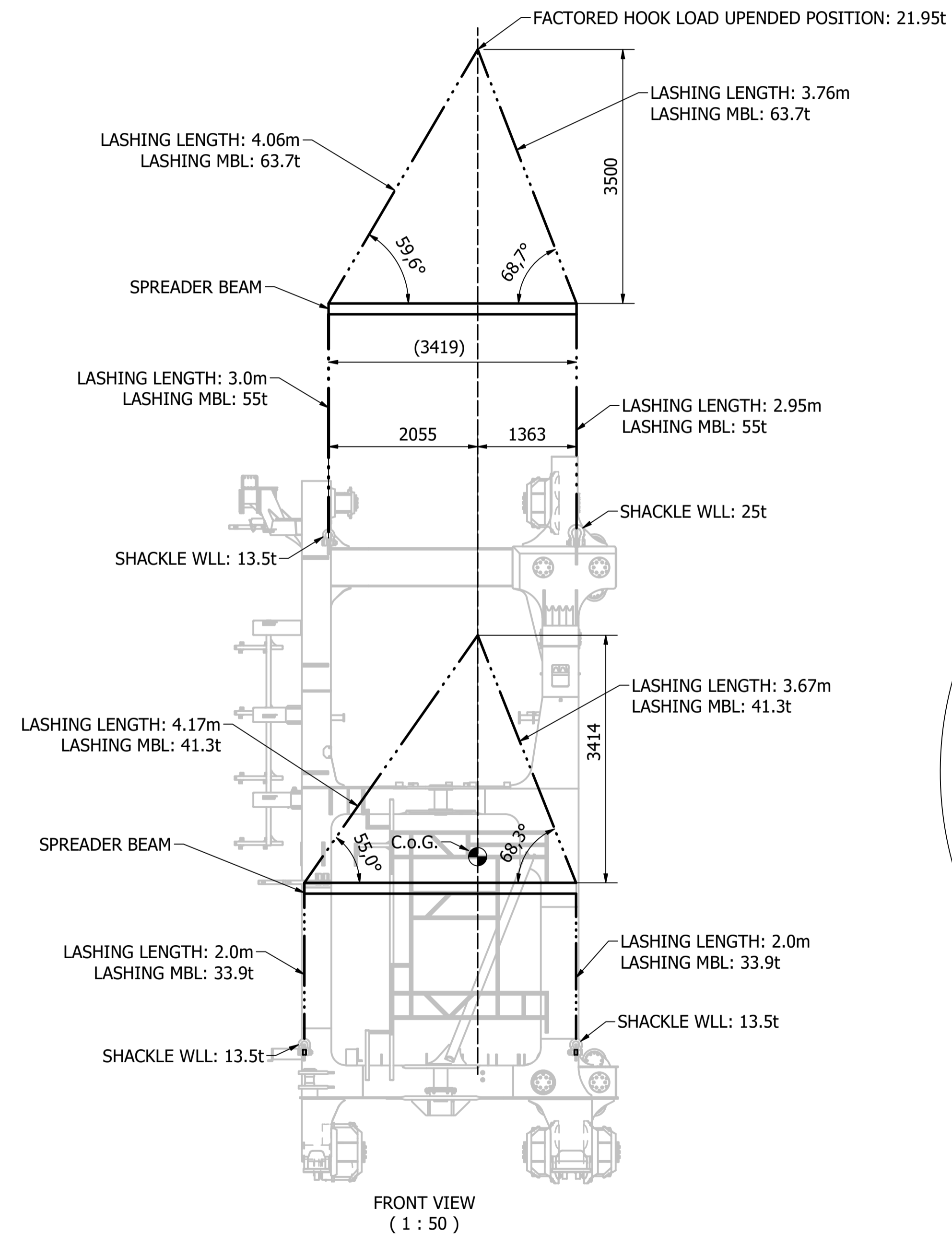

C.o.G. BELOW LIFTING POINT 3.7 DEGREE ANGLE

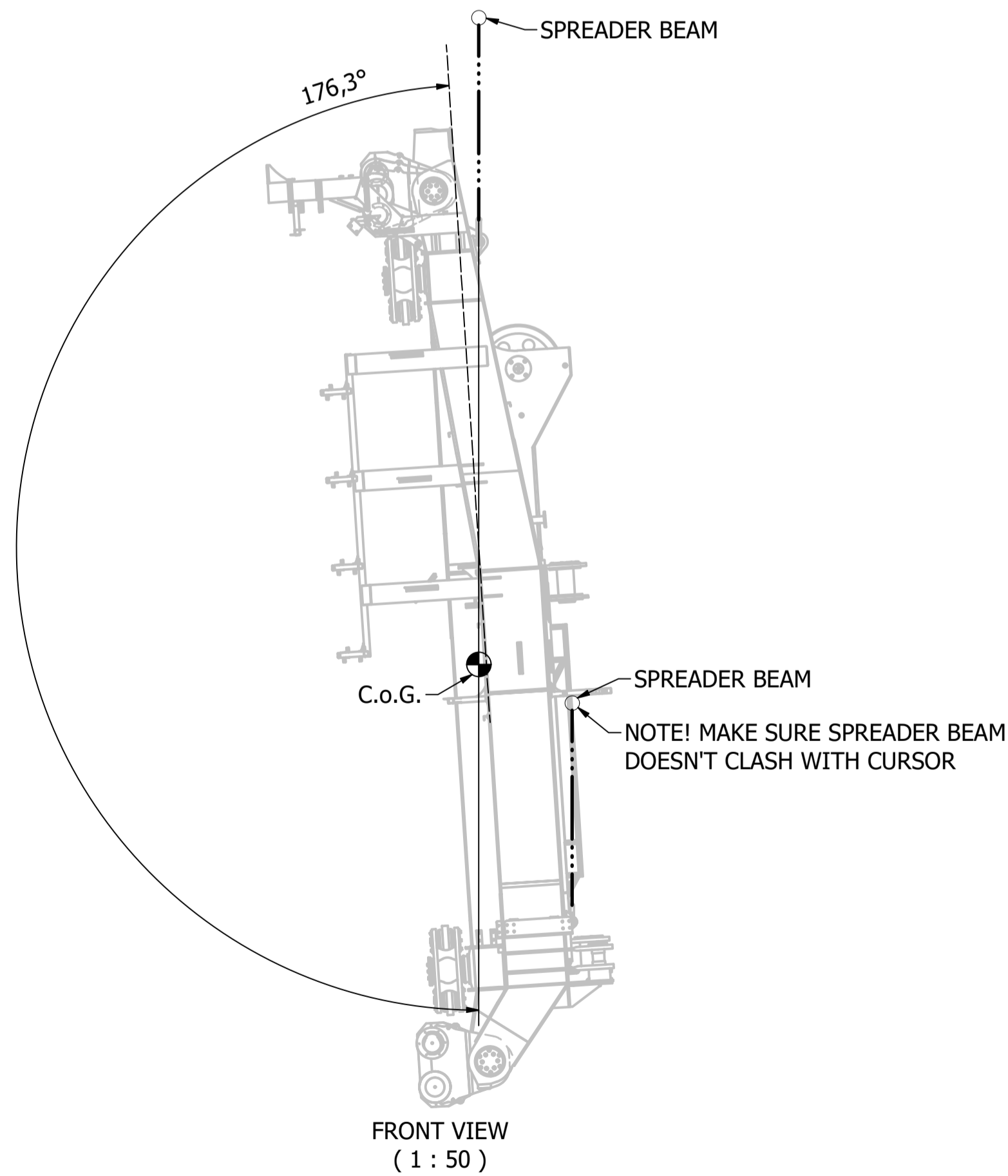

DISTANCE C.o.G. BEHIND LIFTING POINTS

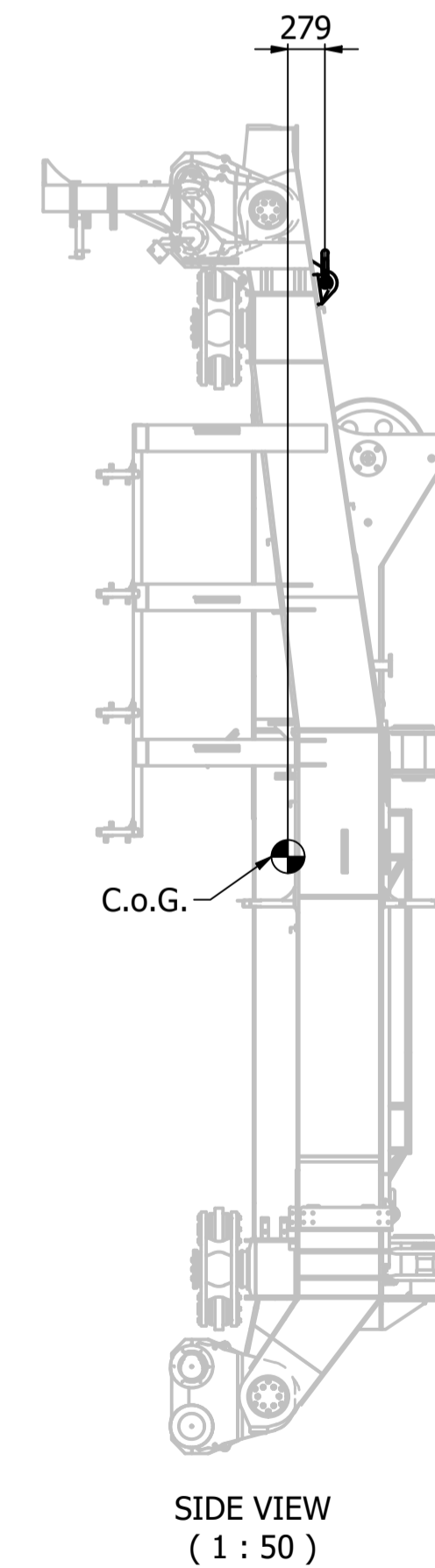



TOTAL WEIGHT: 18879 kg

- NOTES:
1. THIS DRAWING SHOWS DETAILS REGARDING UPENDING/HORIZONTAL LIFTING OF CURSOR
 2. ALL RIGGING ITEMS TO BE SUPPLIED BY LIFTING CONTRACTOR.
 3. RIGGING BASED ON LIFTING WITH TWO CRANES.
 4. MBL BASED ON SF OF 2.8.
 5. ALL RIGGING CAPACITIES BASED ON STEEL WIRE ROPE.

REV	DATE	DESCRIPTION	PREPARED	CHECKED	DIS.CHECK	APPROVED
01	03-12-2024	ISSUED FOR INFORMATION	DBa	TTW	FG	FD

Proprietary Rights, Intellectual Property and Confidentiality Notice.
Copyright 2021 UPTIME International AS. All right reserved.
This document contains and is intended to convey confidential and proprietary information which is the exclusive intellectual property of UPTIME International AS. This document, in electronic or hard copy format and any attachments included with or reference therein, MAY NOT by any means be reproduced, duplicated, distributed, shared, disclosed or used for any purpose without the express written permission of UPTIME International AS.

	PROJECT VESSEL DESIGN/ ID : BY151
	CLIENT Cochin Shipyard Ltd.

Project: 2320000 - Uptime 148	ALL DIMENSIONS IN mm U.N.O
Title: TELESCOPIC GANGWAY 30m 3.0 ELECTRIC CURSOR CURSOR UPENDING	
Drawing No: 2320000-UI-4020-N-XD-830-0015	Sheet: 830-0015
Sub. No. Sheet	Rev. No. 01

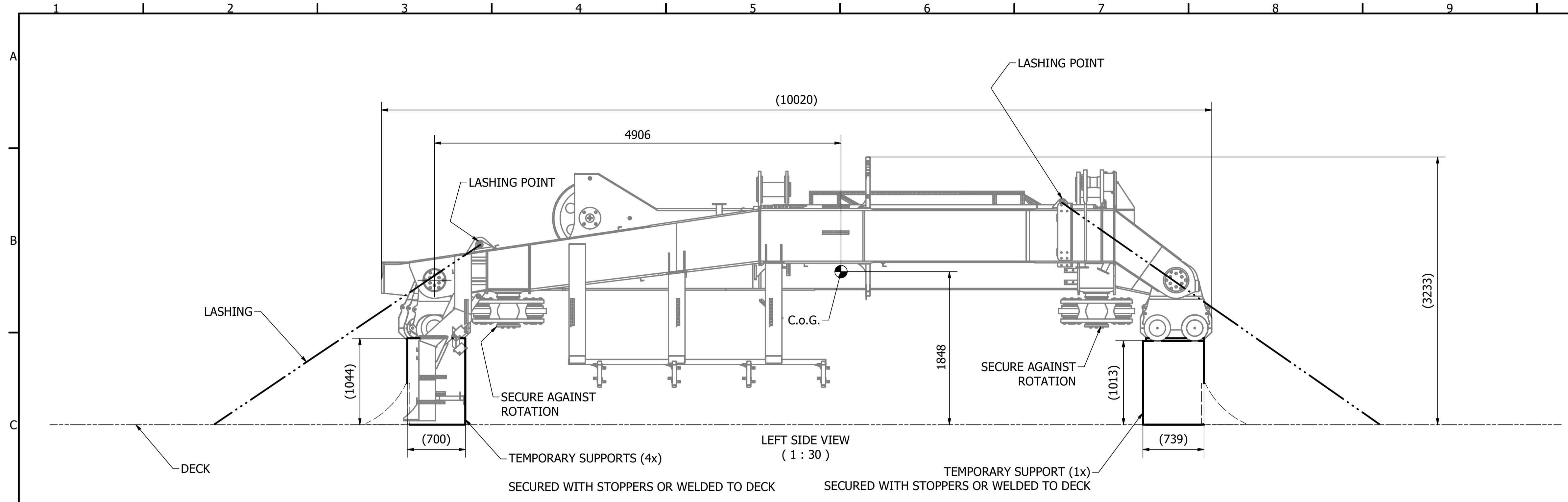

- NOTES:
1. TEMPORARY SUPPORTS MAY BE STEEL BEAMS WITH PROTECTIVE RUBBER/WOOD.
 2. LASHING ON DRAWING IS FOR INDICATION ONLY. EXACT CONFIGURATION AND CAPACITY OF LASHING TO BE DETERMINED BY SHIPPING COMPANY.
 3. TEMPORARY SUPPORT DIMENSIONS MAY DIFFER SLIGHTLY, AS LONG AS EVERYTHING STAYS CLEAR AND PROTECTED.

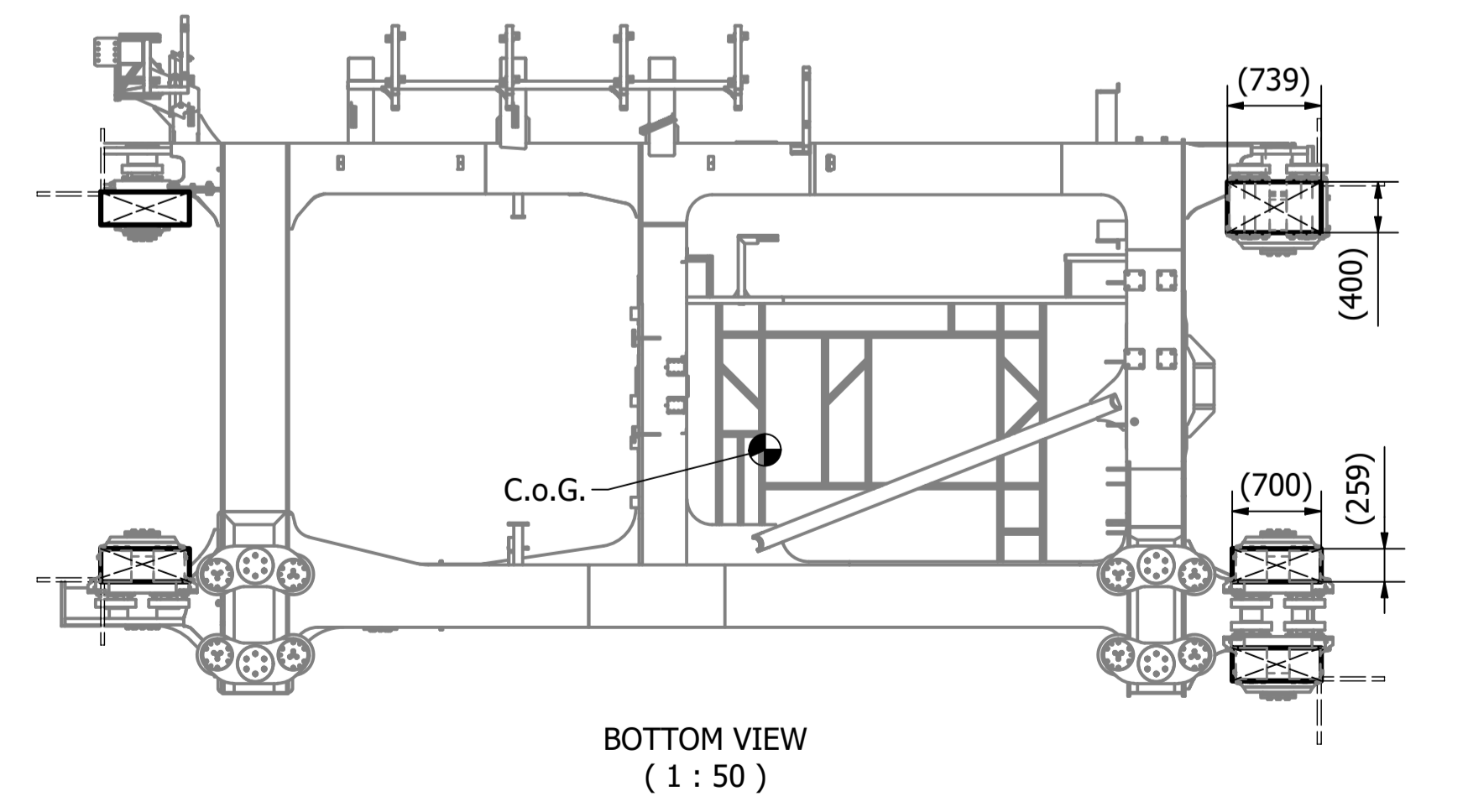
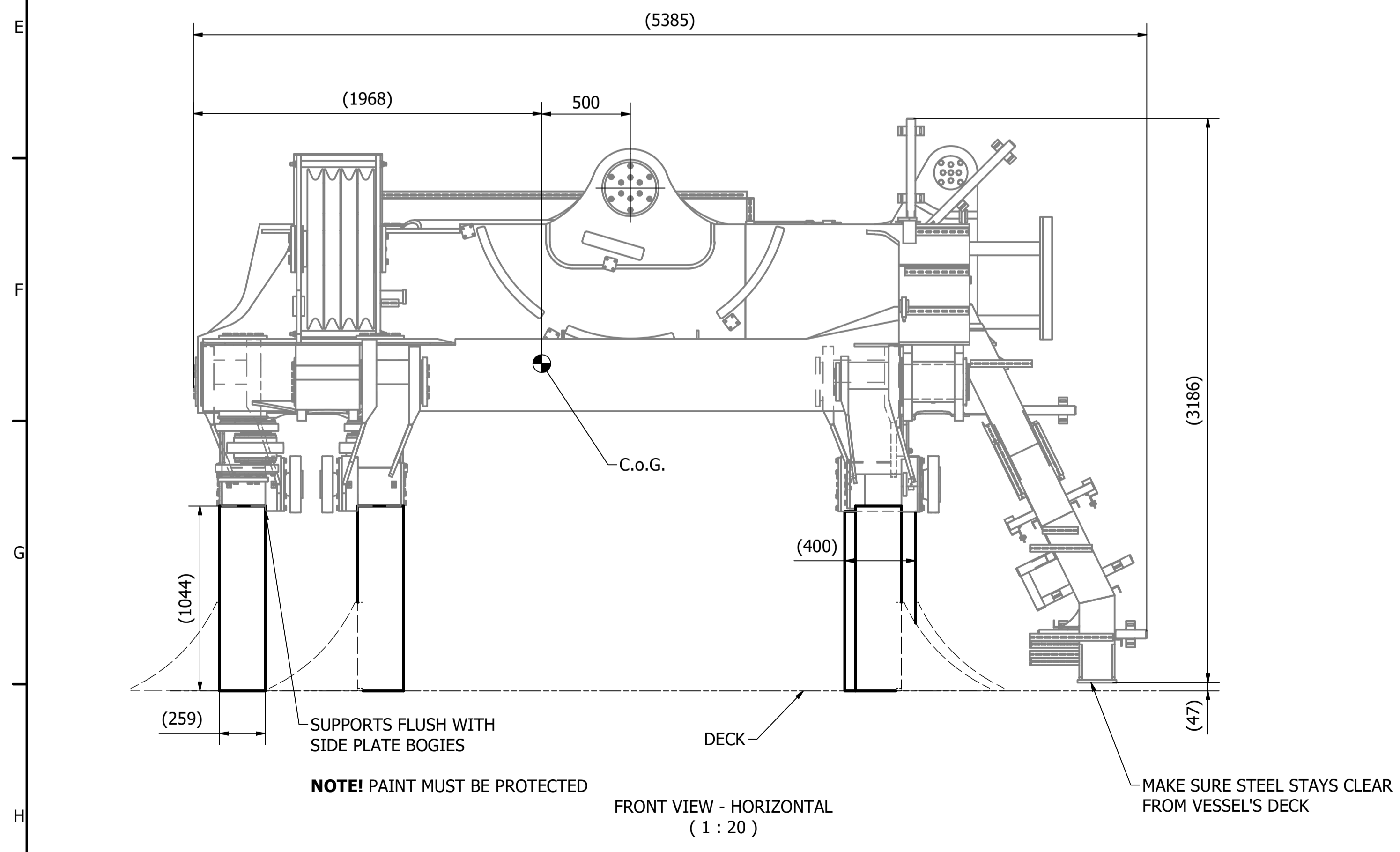
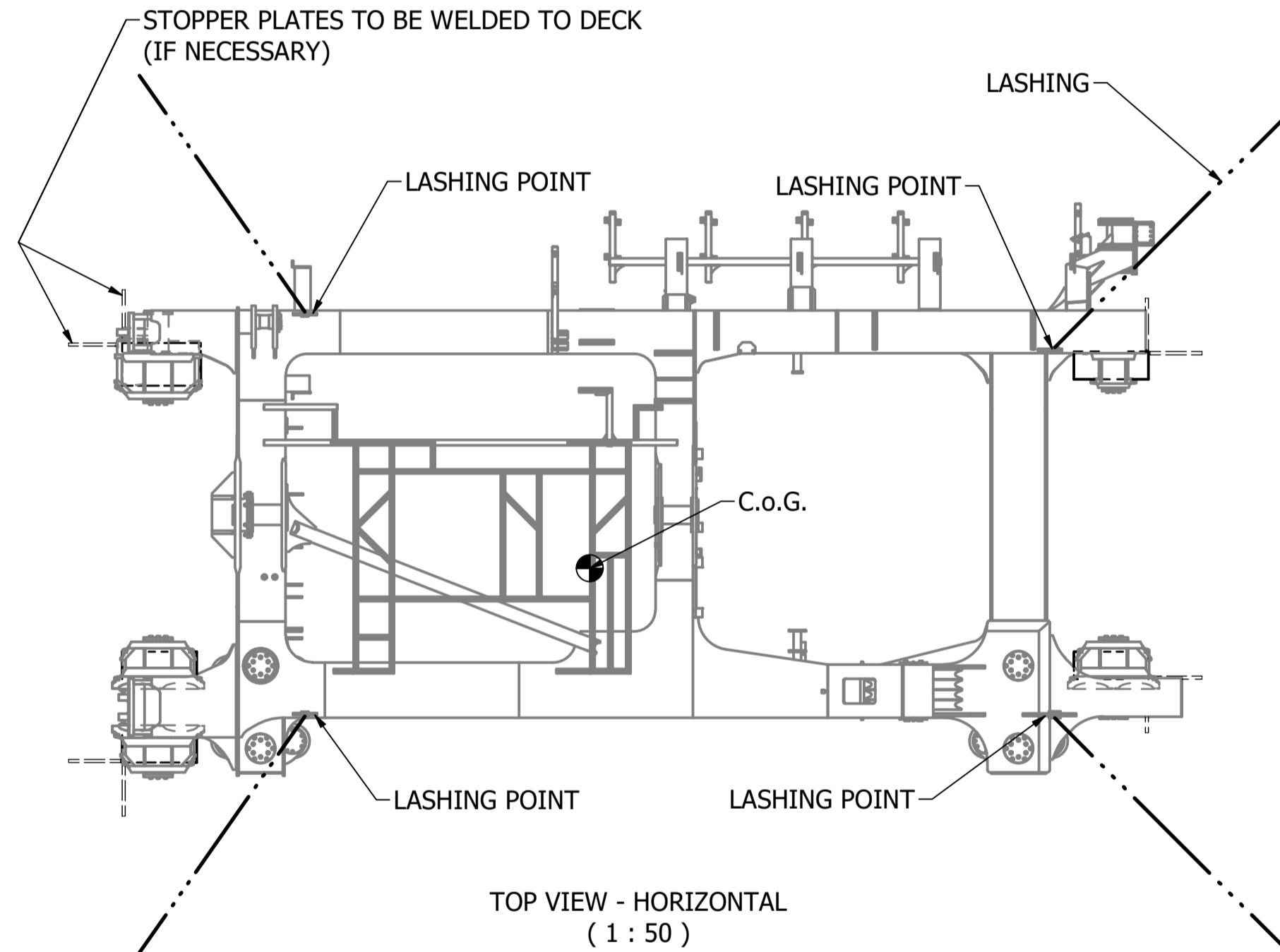
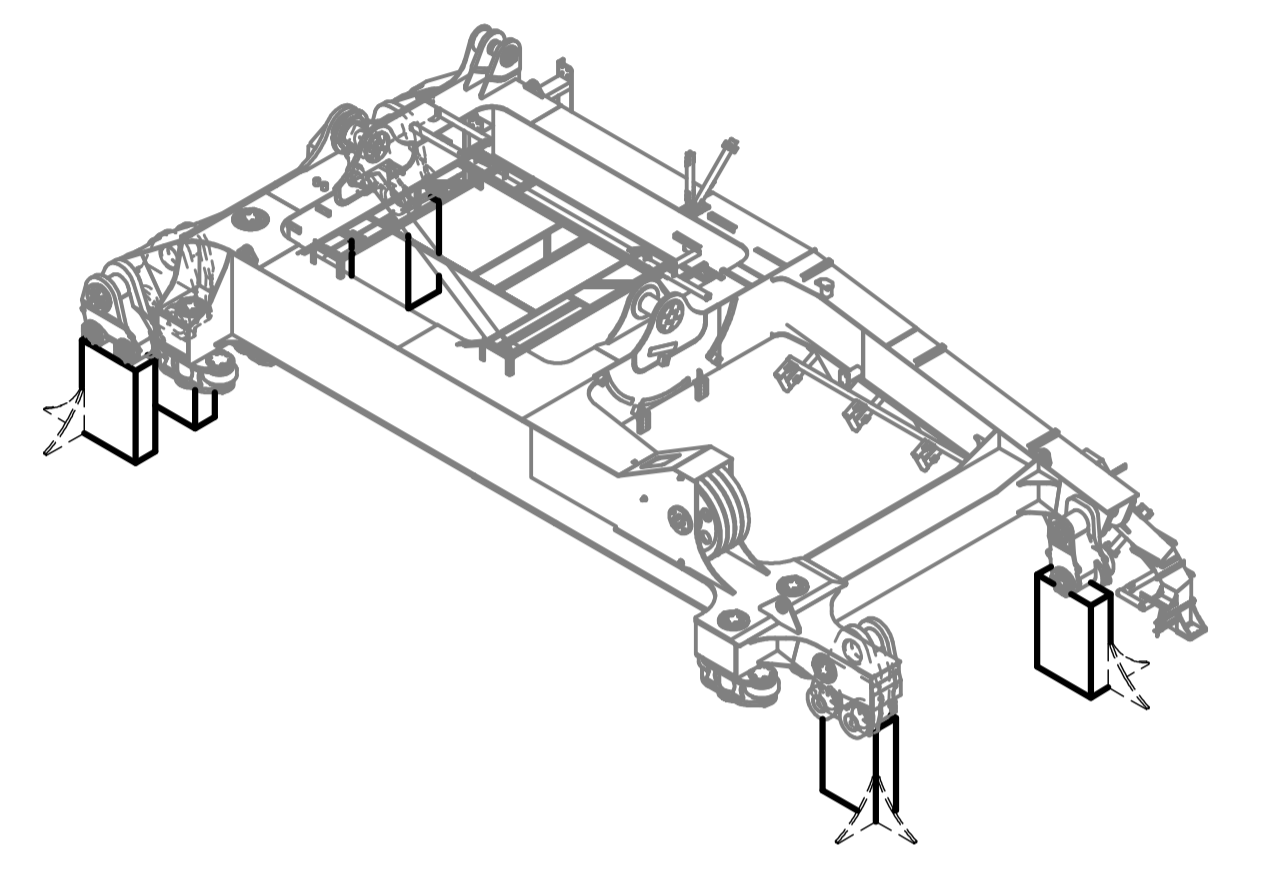

REV	DATE	DESCRIPTION	PREPARED	CHECKED	DIS.CHECK	APPROVED
01	13-01-2025	Issued For Information	DBa	TTW	FG	FD

Proprietary Rights, Intellectual Property and Confidentiality Notice.
 Copyright 2021 UPTIME International AS. All right reserved.
 This document contains and is intended to convey confidential and proprietary information which is the exclusive intellectual property of UPTIME International AS. This document, in electronic or hard copy format and any attachments included with or reference therein, MAY NOT by any means be reproduced, duplicated, distributed, shared, disclosed or used for any purpose without the express written permission of UPTIME International AS.

	PROJECT VESSEL DESIGN/ ID :
	BY 151

	SUB SUPPLIER :
	CLIENT Cochin Shipyards Ltd.

Project: 2320000 - Uptime 148		ALL DIMENSIONS IN mm U.N.O.	
Title: TELESCOPIC GANGWAY 30m 3.0 ELECTRIC CURSOR			
CURSOR TRANSPORT - SHEET 1			
Drawing No: 2320000-UI-4020-N-XD-830-0017	Vault Ref: 830-0017	Rev: 01	
Proj. No. Origin. Prod. No. Disc. Doc. Sub. No. Sheet	Sub. No. Sheet	Rev. No.	

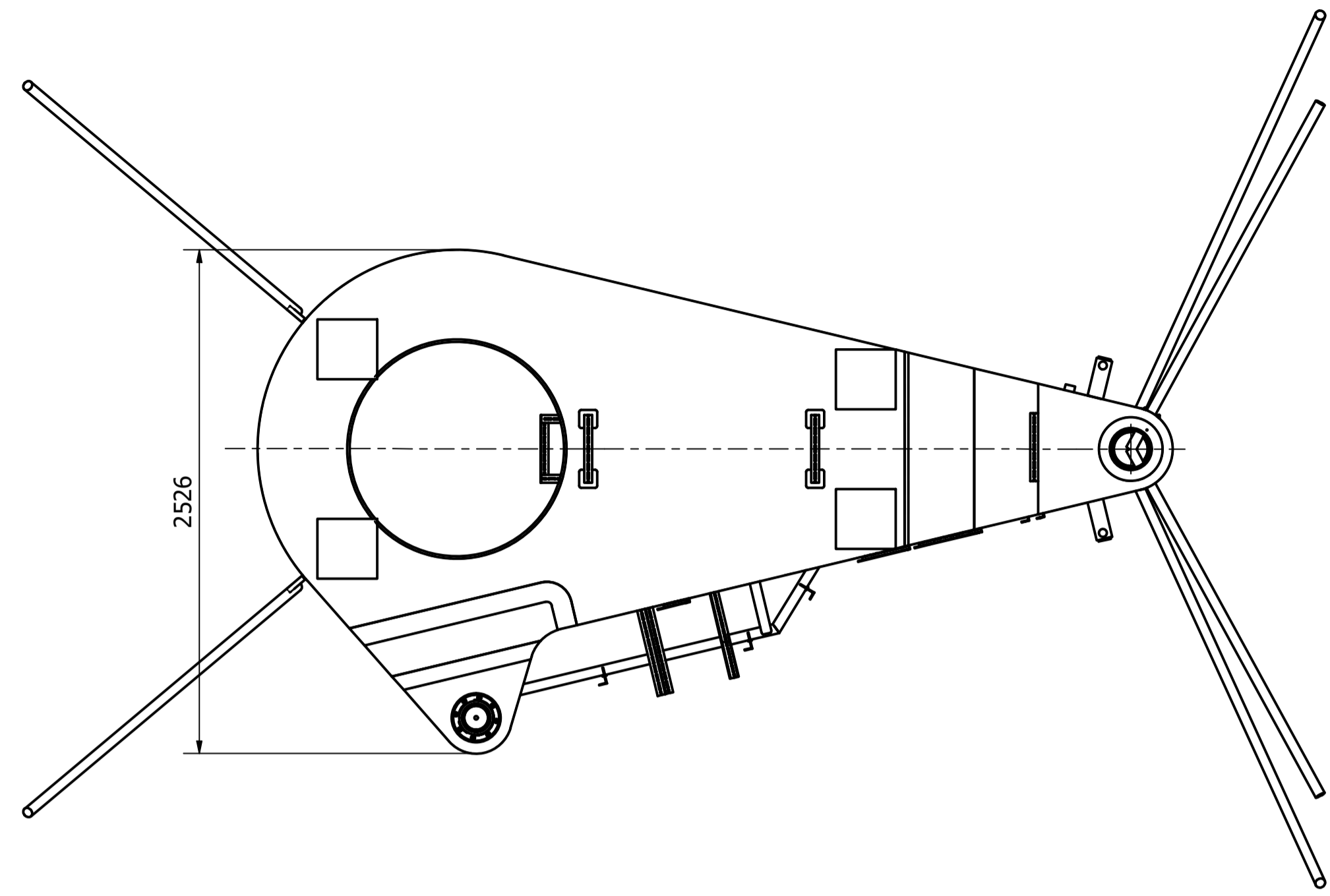

BOTTOM VIEW
(1:25)

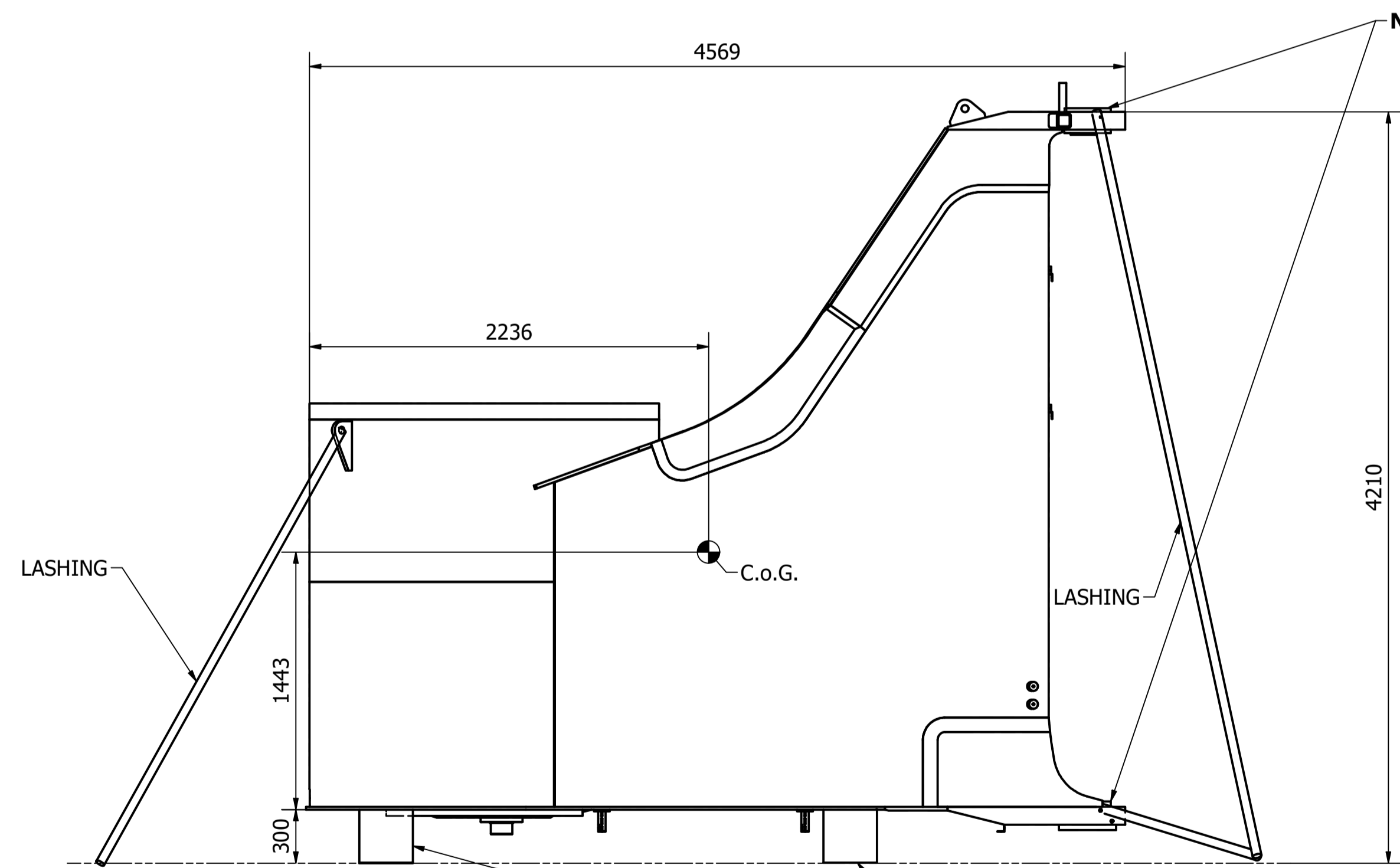

BOTTOM VIEW
(1:25)

HARD WOOD 300x300 mm

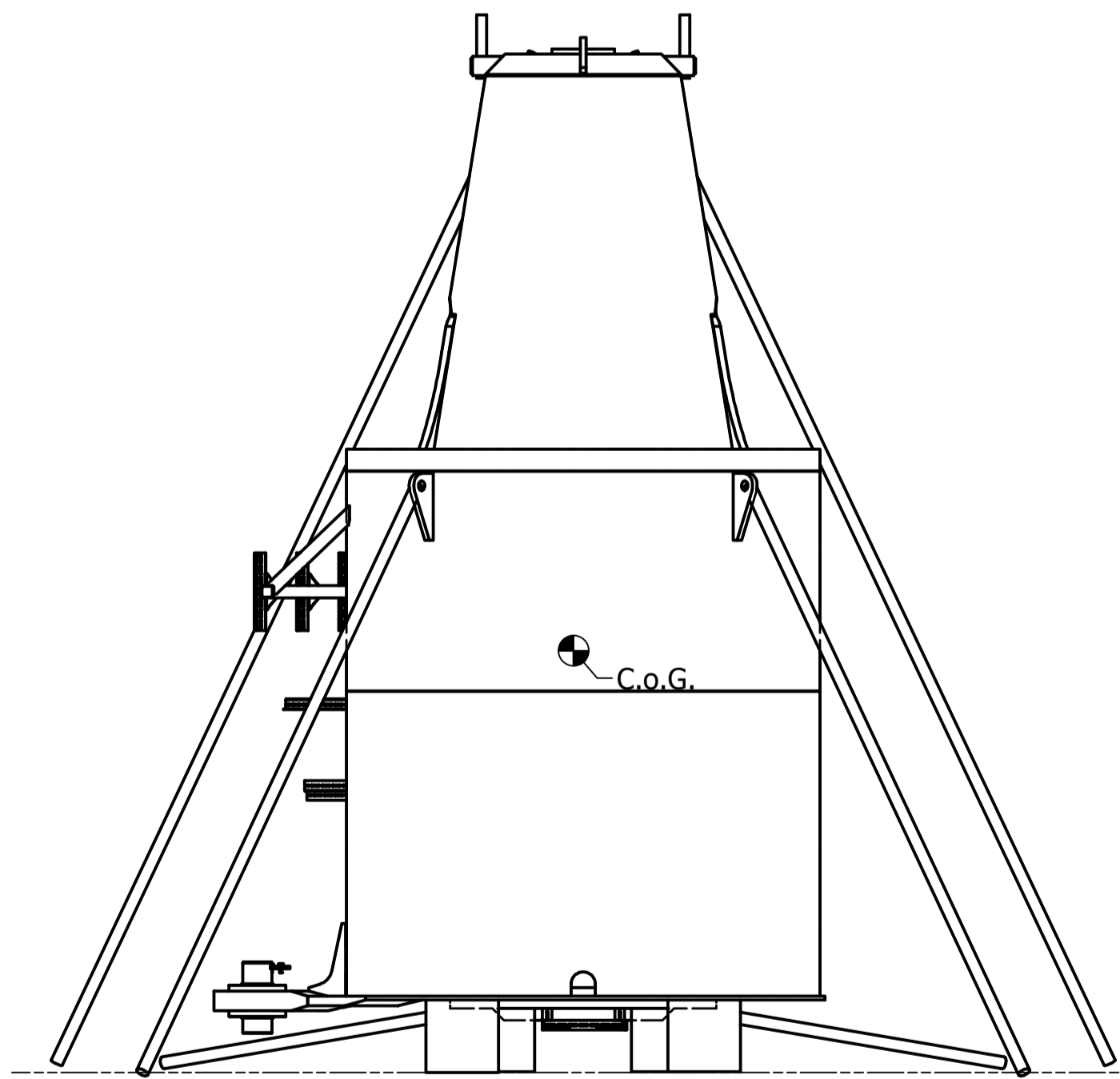

BOTTOM VIEW
(1:25)

NOTES:

1. HARD WOOD MAY BE REPLACED BY STEEL BEAM WITH PROTECTIVE RUBBER.
2. LASHING ON DRAWING IS FOR INDICATION ONLY. EXACT CONFIGURATION AND CAPACITY OF LASHING TO BE DETERMINED BY SHIPPING COMPANY.

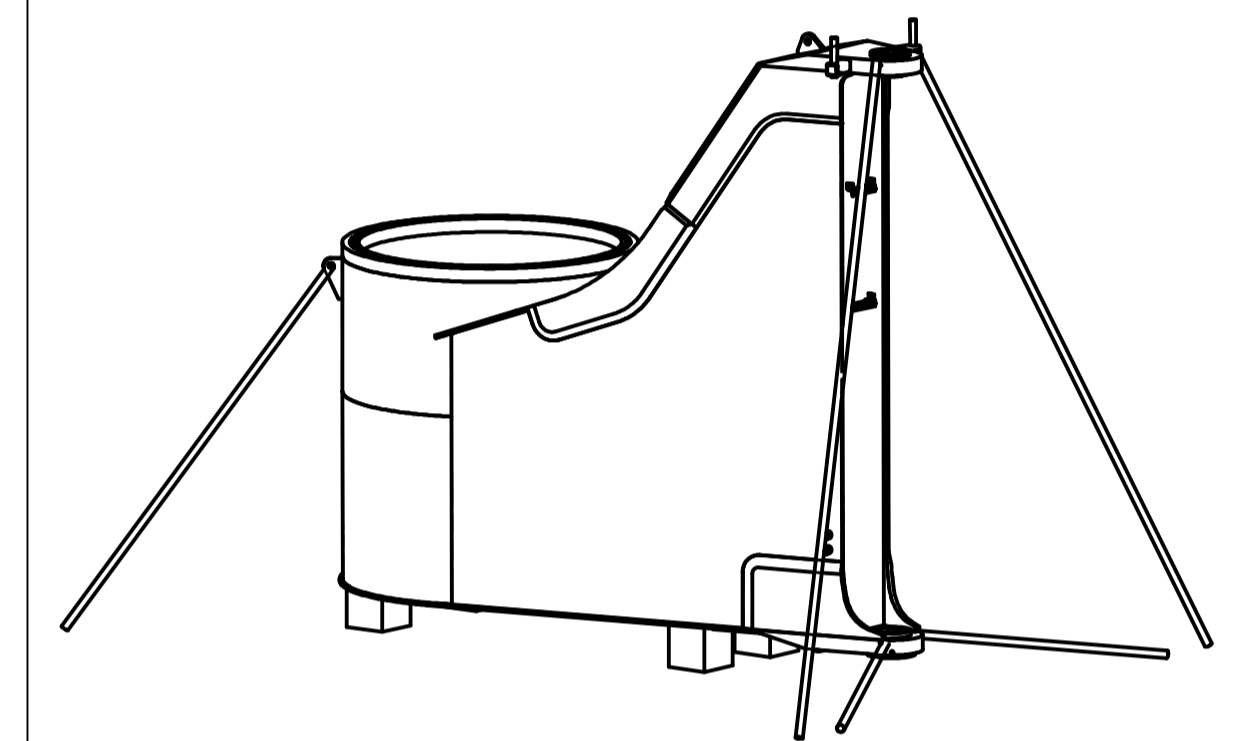

Total Weight: 7170 kg

REV	DATE	DESCRIPTION	PREPARED	CHECKED	DIS.CHECK	APPROVED
01	06-12-2024	Issued For Information	DBa	TTW	FG	FD

Proprietary Rights, Intellectual Property and Confidentiality Notice.
Copyright 2021 UPTIME International AS. All right reserved.
This document contains and is intended to convey confidential and proprietary information which is the exclusive intellectual property of UPTIME International AS. This document, in electronic or hard copy format and any attachments included with or reference therein, MAY NOT by any means be reproduced, duplicated, distributed, shared, disclosed or used for any purpose without the express written permission of UPTIME International AS.

	PROJECT VESSEL DESIGN/ ID : BY151
---	--------------------------------------

	CLIENT: COCHIN SHIPYARD Ltd.
---	---------------------------------

Project: 2320000 - Uptime 148 - BY151
Title: TELESCOPIC GANGWAY 30m 3.0 ELECTRIC HINGE TRANSPORT DRAWING
ALL DIMENSIONS IN mm U.N.O.

Drawing No: 2320000-UI-4020-N-XD-830-5011	Vault Ref: 830-5011	Rev: 01
--	------------------------	------------

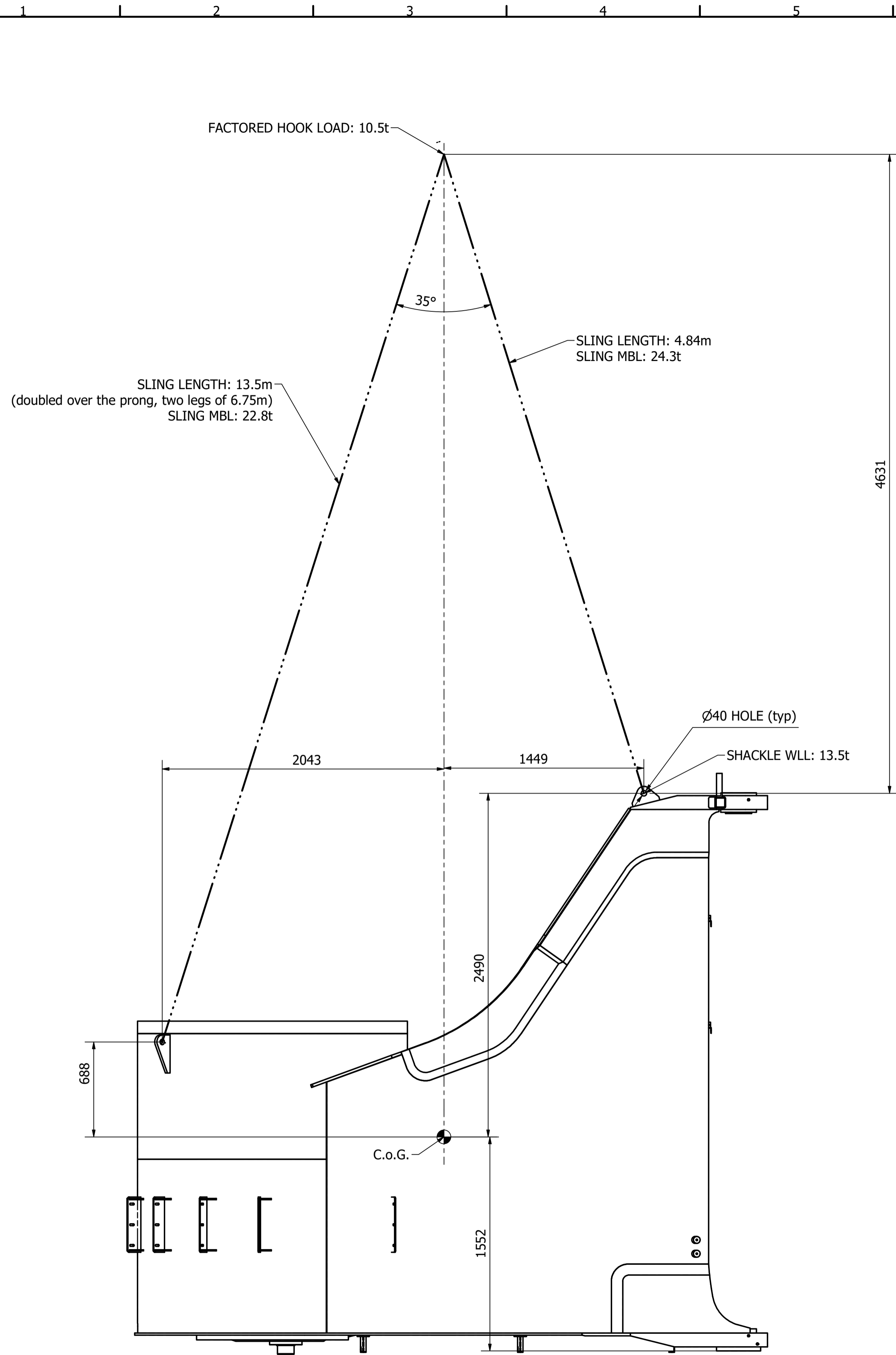

SIDE VIEW
(1:20)

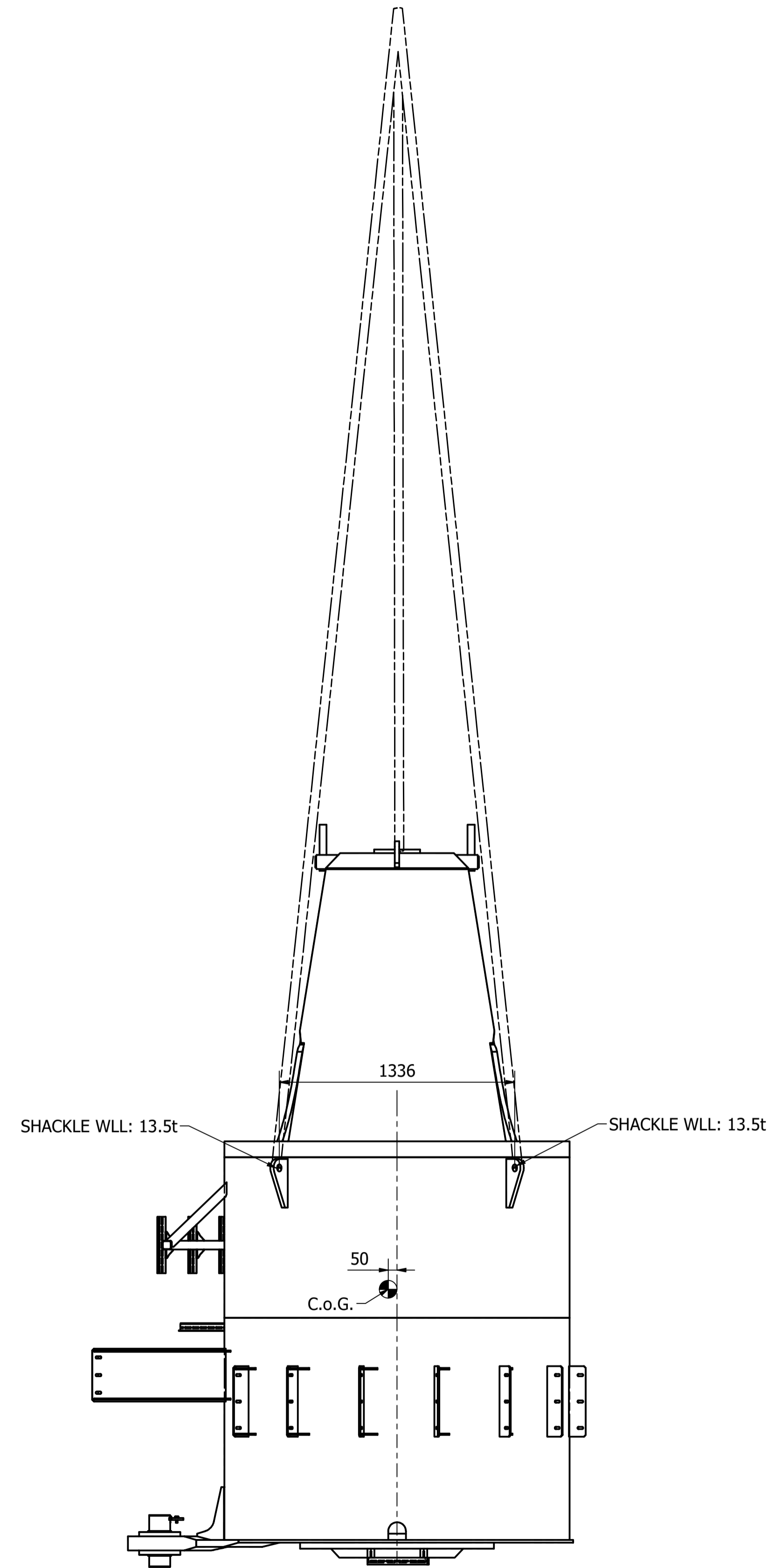

FRONT VIEW

- NOTES:
1. ALL RIGGING ITEMS TO BE SUPPLIED BY LIFTING CONTRACTOR.
 2. MBL DOUBLED SLING BASED ON SF OF 5.6.
 3. MBL SINGLE SLING BASED ON SF OF 3.1.
 3. ALL RIGGING CAPACITIES BASED ON STEEL WIRE ROPE.

Total Weight: 7257 kg

REV	DATE	DESCRIPTION	PREPARED	CHECKED	DIS.CHECK	APPROVED
01	06-12-2024	Issued For Information	DBa	TTW	FG	FD

Proprietary Rights, Intellectual Property and Confidentiality Notice.
Copyright 2021 UPTIME International AS. All right reserved.
This document contains and is intended to convey confidential and proprietary information which is the exclusive intellectual property of UPTIME International AS. This document, in electronic or hard copy format and any attachments included with or reference therein, MAY NOT by any means be reproduced, duplicated, distributed, shared, disclosed or used for any purpose without the express written permission of UPTIME International AS.

ENGINEERING AND FABRICATION :	PROJECT VESSEL DESIGN/ ID :
	BY151

SUB SUPPLIER :	CLIENT :
	COCHIN SHIPYARD Ltd.

Project: 2320000 - Uptime 148 - BY151 ALL DIMENSIONS IN mm U.N.O

Title: TELESCOPIC GANGWAY 30m HINGE LIFT ARRANGEMENT

Drawing No. 2320000-UI-4020-N-XD-830-5013	Vault Ref. 830-5013	Rev. 01
---	---------------------	---------

Proj. No.	Origin	Prod. No.	Disc.	Doc.	Sub. No.	Sheet	Sub. No.	Sheet	Rev. No.
-----------	--------	-----------	-------	------	----------	-------	----------	-------	----------

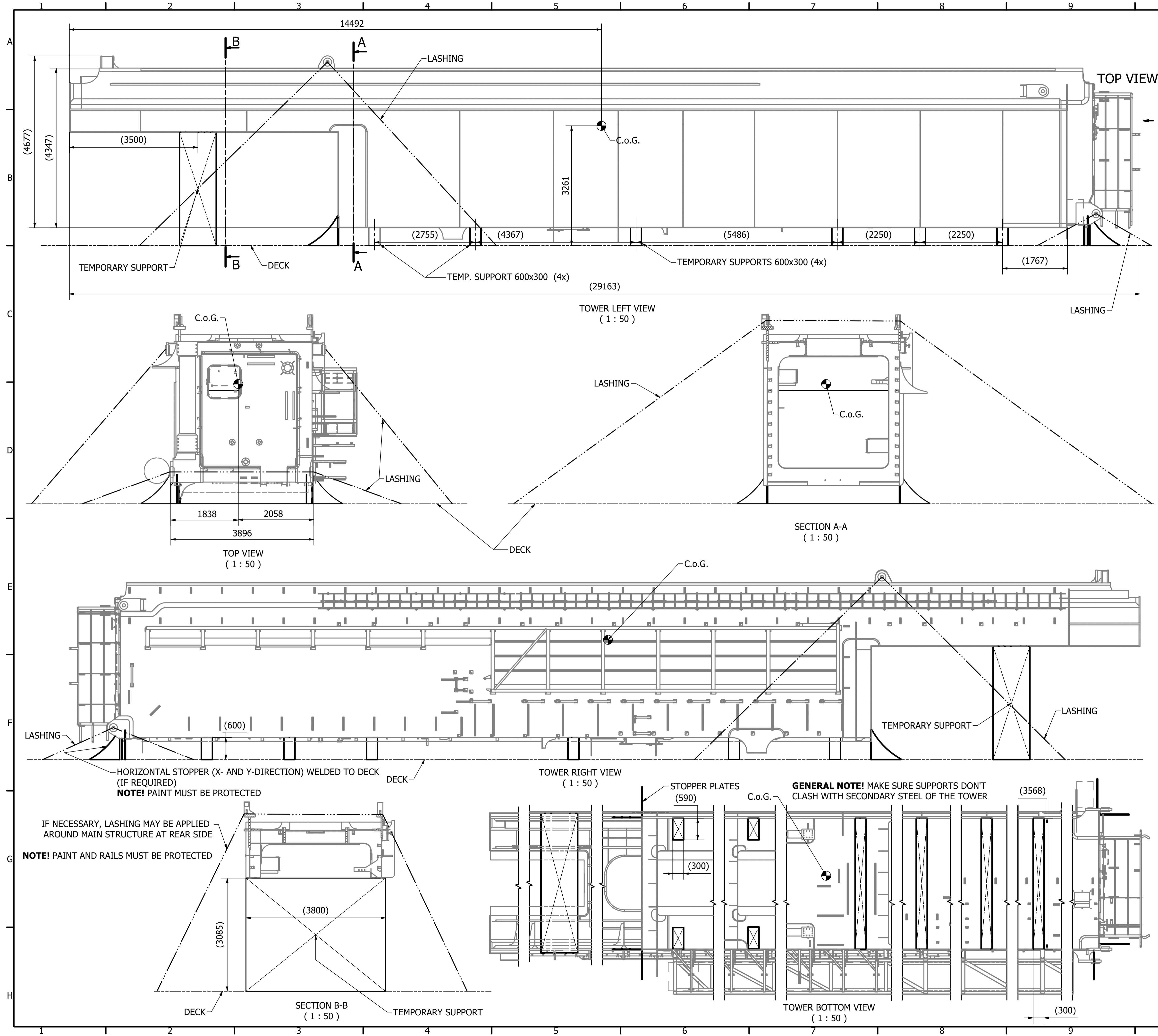

NOTES:

1. TEMPORARY SUPPORTS 600x300 e.g. HEB WITH WOOD ON TOP.
2. LASHING ON DRAWING IS FOR INDICATION ONLY. EXACT CONFIGURATION AND CAPACITY OF LASHING TO BE DETERMINED BY SHIPPING COMPANY.

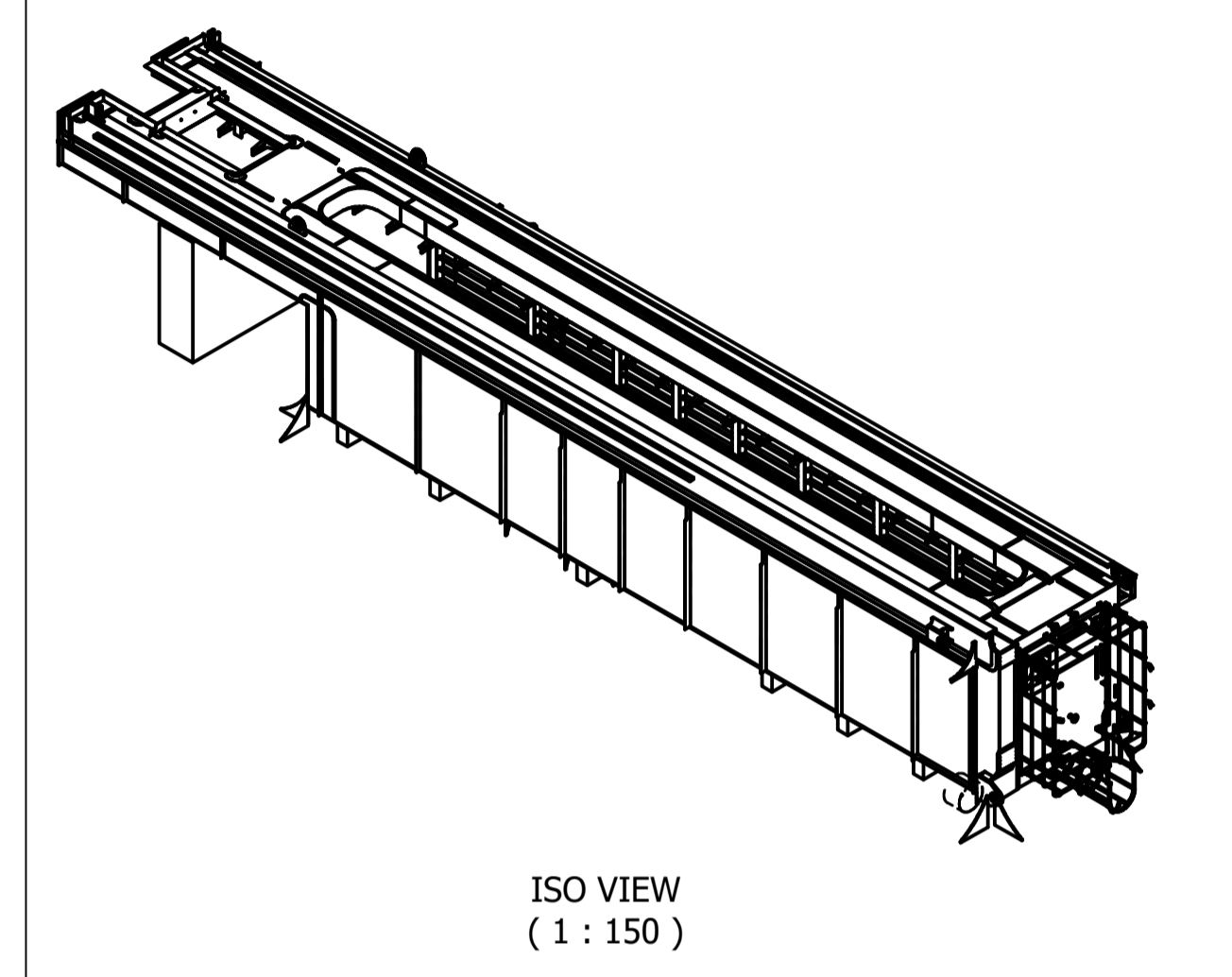

Total Weight: 83604 kg

REV	DATE	DESCRIPTION	PREPARED	CHECKED	DIS.CHECK	APPROVED
01	13-01-2025	Issued for information	DBa	TTW	FG	FD

Proprietary Rights, Intellectual Property and Confidentiality Notice.
 Copyright 2021 UPTIME International AS. All right reserved.
 This document contains and is intended to convey confidential and proprietary information which is the exclusive intellectual property of UPTIME International AS. This document, in electronic or hard copy format and any attachments included with or reference therein, MAY NOT be reproduced, duplicated, distributed, shared, disclosed or used for any purpose without the express written permission of UPTIME International AS.

	PROJECT VESSEL DESIGN/ ID:
	BY151
SUB SUPPLIER:	CLIENT:
	Cochin Shipyards Ltd.

Project:	2320000 - Uptime 148	ALL DIMENSIONS IN mm U.N.O.
Title:	TELESCOPIC GANGWAY 30m 3.0 ELECTRIC STEEL ELEVATOR TOWER TOWER TRANSPORT - SHEET 1	
Drawing No:	2320000-UI-4020-N-XG-710-5010	Vault Ref: 710-5010
Rev. No:	01	

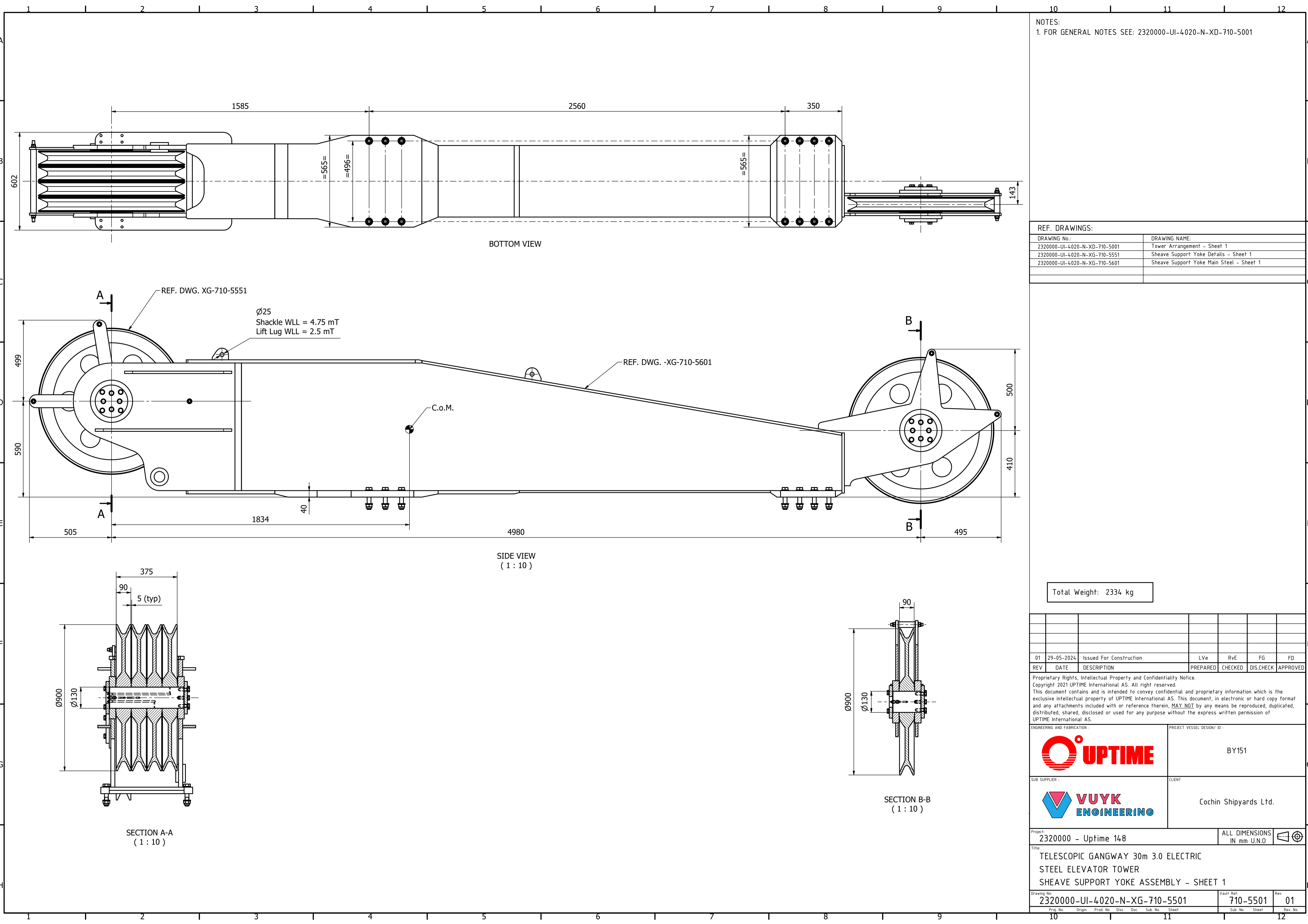

NOTES:
1. FOR GENERAL NOTES SEE: 2320000-UI-4020-N-XD-710-5001

REF. DRAWINGS:	
DRAWING No.:	DRAWING NAME:
2320000-UI-4020-N-XD-710-5001	Tower Arrangement - Sheet 1
2320000-UI-4020-N-XG-710-5551	Sheave Support Yoke Details - Sheet 1
2320000-UI-4020-N-XG-710-5601	Sheave Support Yoke Main Steel - Sheet 1

Total Weight: 2334 kg

REV	DATE	DESCRIPTION	PREPARED	CHECKED	DIS.CHECK	APPROVED
01	29-05-2024	Issued For Construction	LVE	RvE	FG	FD

Proprietary Rights, Intellectual Property and Confidentiality Notice.
Copyright 2021 UPTIME International AS. All right reserved.
This document contains and is intended to convey confidential and proprietary information which is the exclusive intellectual property of UPTIME International AS. This document, in electronic or hard copy format and any attachments included with or reference therein, MAY NOT by any means be reproduced, duplicated, distributed, shared, disclosed or used for any purpose without the express written permission of UPTIME International AS.

	PROJECT VESSEL DESIGN/ ID:
	BY151

	CLIENT:
	Cochin Shipyards Ltd.

Project: 2320000 - Uptime 148		ALL DIMENSIONS IN mm U.N.O	
Title: TELESCOPIC GANGWAY 30m 3.0 ELECTRIC STEEL ELEVATOR TOWER SHEAVE SUPPORT YOKE ASSEMBLY - SHEET 1			
Drawing No. 2320000-UI-4020-N-XG-710-5501	Vault Ref. 710-5501	Rev. 01	
Proj. No.	Origin	Prod. No.	Disc. Doc. Sub. No. Sheet

NOTES:
1. FOR GENERAL NOTES SEE: 2320000-UI-4020-N-XD-710-5001

REF. DRAWINGS:

DRAWING No.:	DRAWING NAME:
2320000-UI-4020-N-XD-710-5001	Tower Arrangement - Sheet 1
2320000-UI-4020-N-XG-710-5701	Winch Platform Main Steel - Sheet 1
2320000-UI-4020-N-XG-711-5721	Winch Platform Handrail - Sheet 1
2320000-UI-4020-N-XG-711-5731	Winch Platform Details - Sheet 1
2320000-UI-4020-N-XG-711-5785	Winch Platform Ladder - Sheet 1

Enclosure and winch with motors not a part of shipment

WINCH PLATFORM DETAILS
REF. DWG.: XG-711-5131

WINCH PLATFORM MAIN STEEL
REF. DWG.: XG-710-5701

WINCH PLATFORM LADDER
REF. DWG.: XG-711-5185

3D VIEW
(1 : 20)

A ↑

PRETENSION ACCORDING TO
SUPPLIER'S SPECIFICATION

VIEW A
(1 : 20)

Pos	Qty	Description	Material	Weight
6	16	Lock Nut M30	10.9 Galv	0.3 kg
5	16	Hex Head Bolt 30x130	10.9 Galv	1 kg
4	32	Washer M30	300 HV	0 kg
3	4	Lock Nut M20	8.8 Galv	0.1 kg
2	4	Hex Head Bolt 20x65	8.8 Galv	0.2 kg
1	8	Washer M20	8.8 Galv	0 kg

REV	DATE	DESCRIPTION	PREPARED	CHECKED	DIS.CHECK	APPROVED
02	22-11-2024	Issued For Construction	DBa	TTW	FG	FD
01	18-09-2024	Issued For Construction	SSI	TTW	FG	FD

Proprietary Rights, Intellectual Property and Confidentiality Notice.
Copyright 2021 UPTIME International AS. All right reserved.
This document contains and is intended to convey confidential and proprietary information which is the exclusive intellectual property of UPTIME International AS. This document, in electronic or hard copy format and any attachments included with or reference therein, MAY NOT by any means be reproduced, duplicated, distributed, shared, disclosed or used for any purpose without the express written permission of UPTIME International AS.

	PROJECT VESSEL DESIGN/ ID : BY151
---	--------------------------------------

	CLIENT: Cochin Shipyards Ltd.
---	----------------------------------

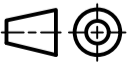
Project: 2320000 - Uptime 148 ALL DIMENSIONS IN mm U.N.O. 

Title:
TELESCOPIC GANGWAY 30m 3.0 ELECTRIC
STEEL ELEVATOR TOWER
WINCH PLATFORM ASSEMBLY - SHEET 1

Drawing No: 2320000-UI-4020-N-XG-710-5711	Vault Ref: 710-5711	Rev: 02
--	------------------------	------------

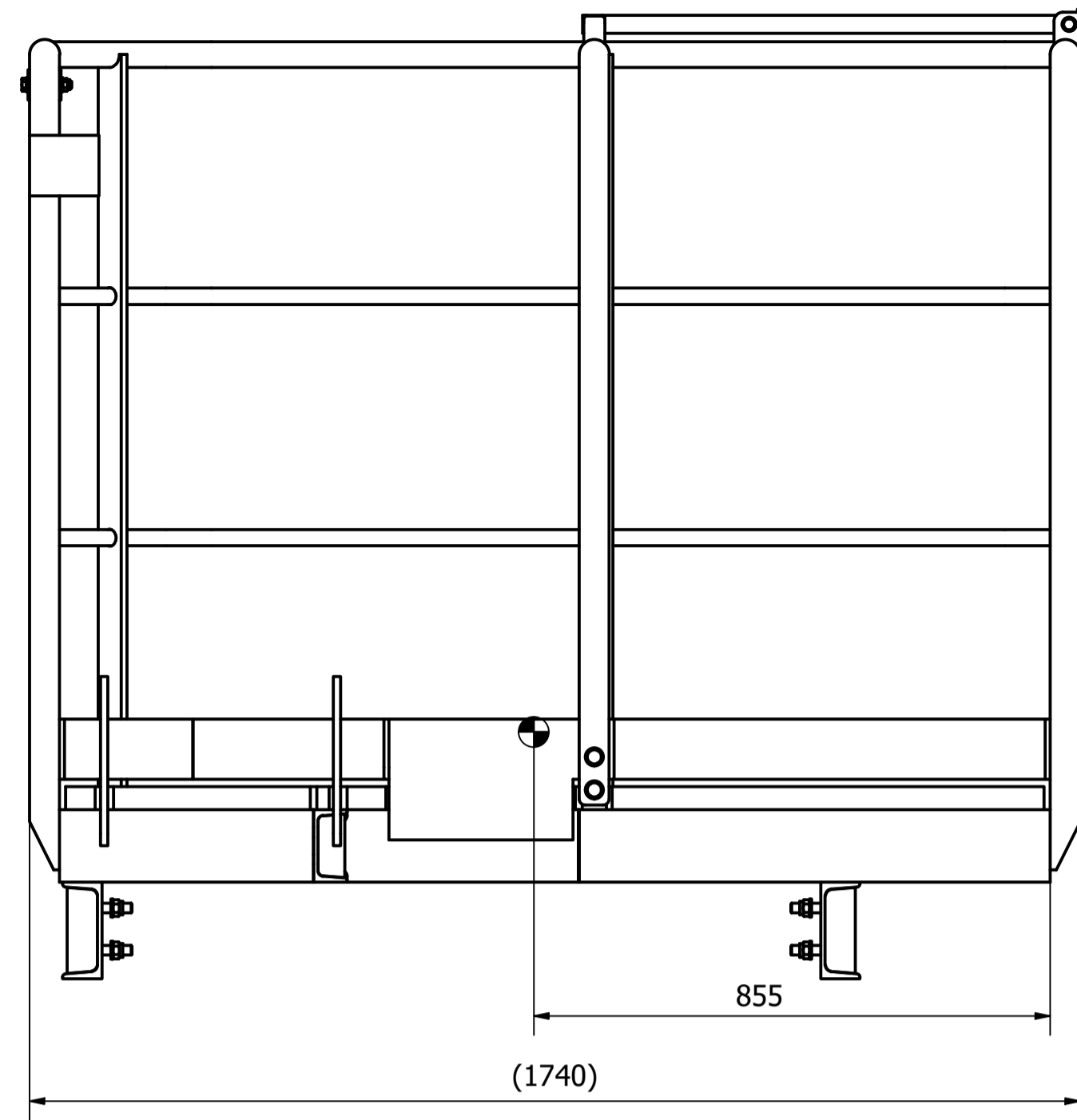

SIDE VIEW
(1:10)

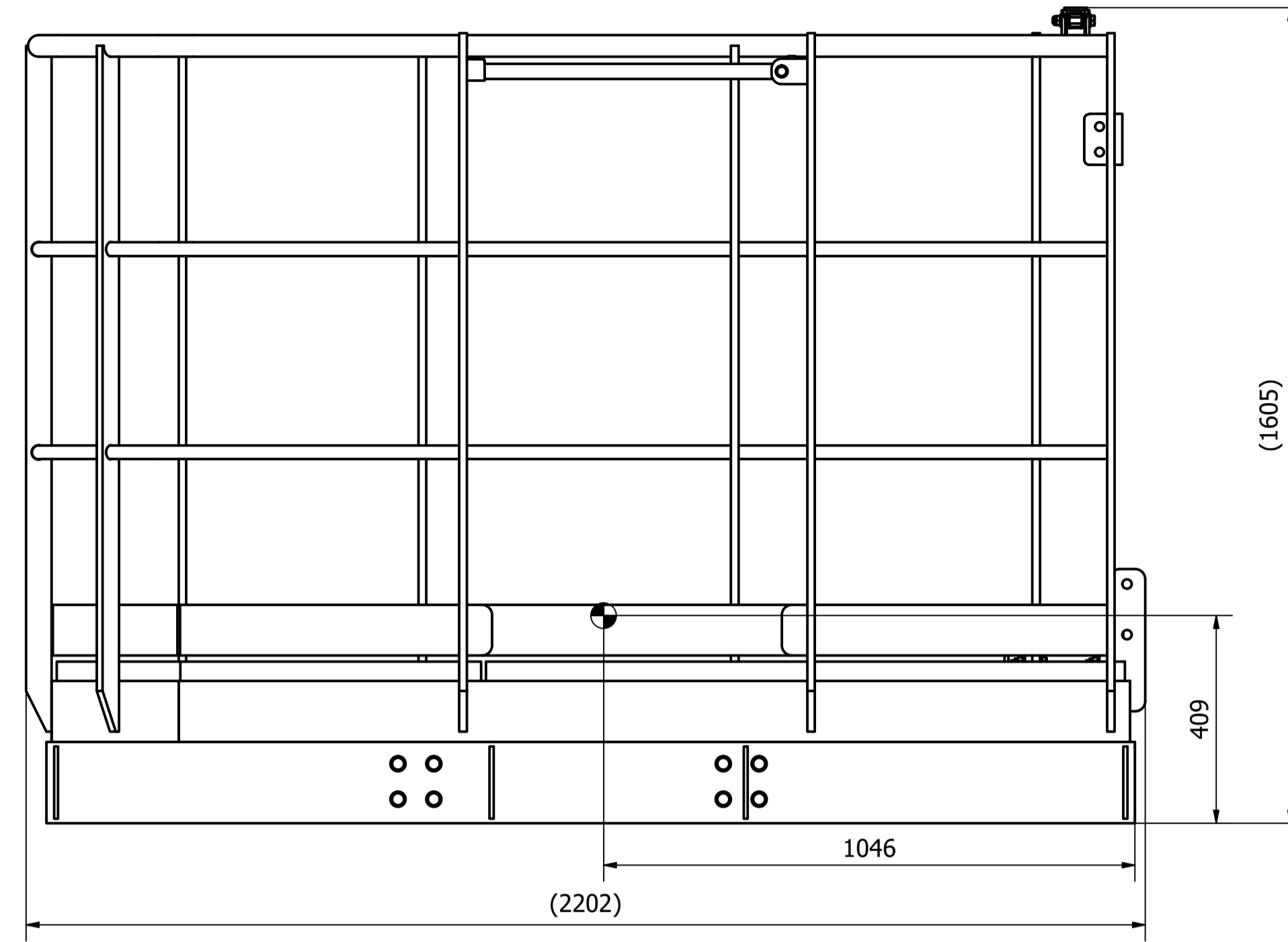

FRONT VIEW
(1:10)

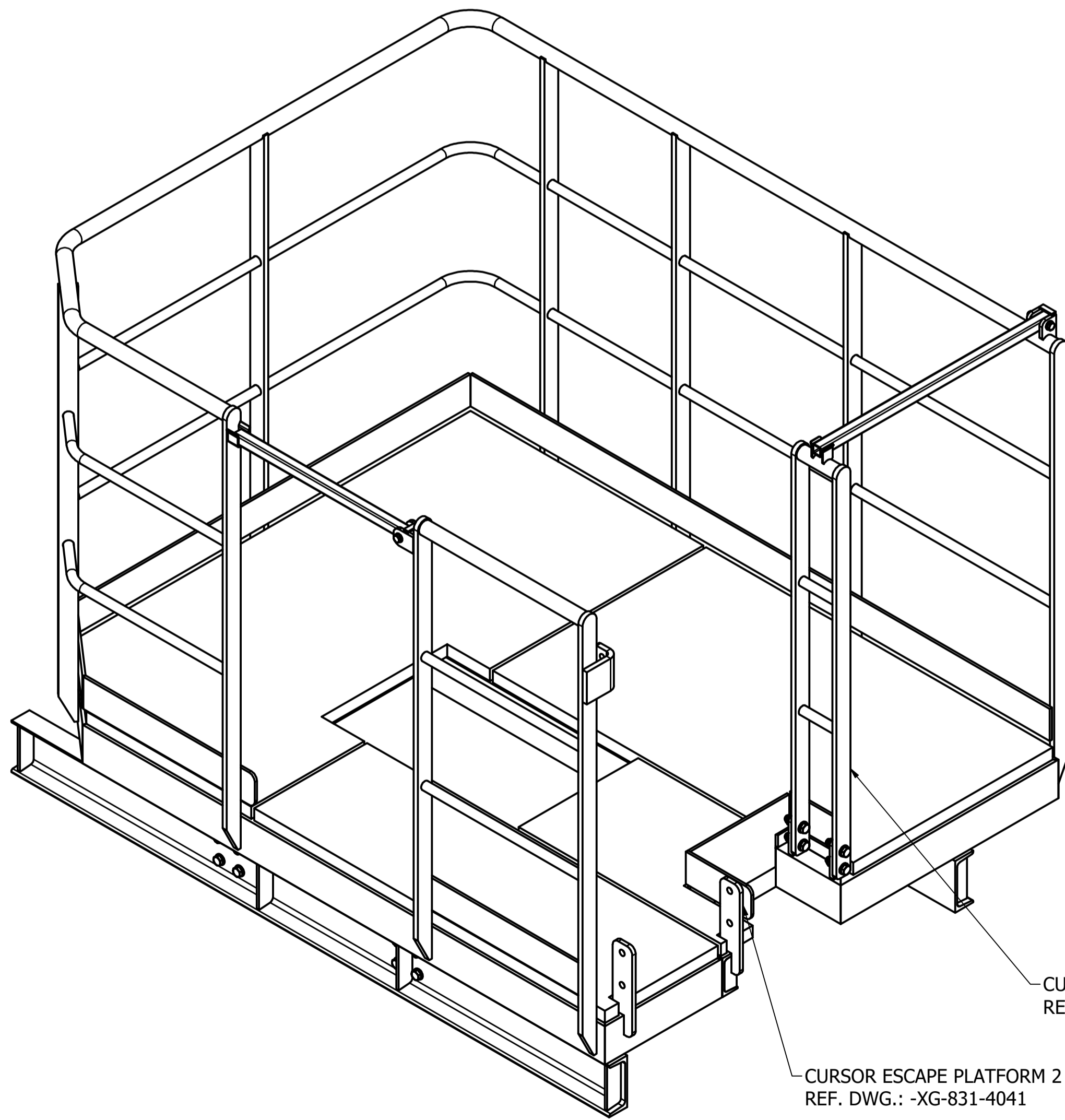

TOP ISO VIEW

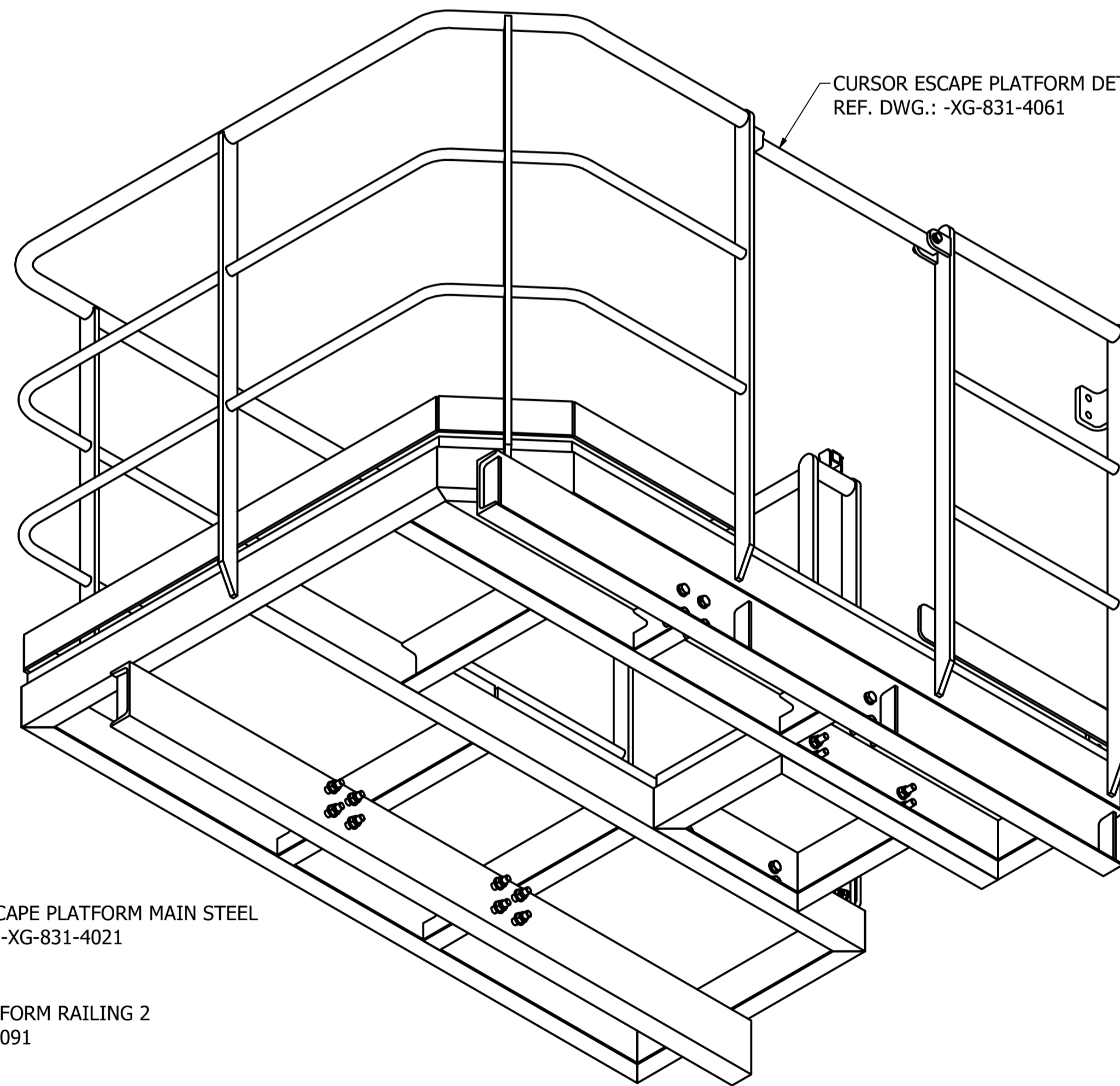

BOTTOM ISO VIEW

CURSOR ESCAPE PLATFORM MAIN STEEL
REF. DWG.: -XG-831-4021

CURSOR ESCAPE PLATFORM RAILING 2
REF. DWG.: -XG-831-4091

CURSOR ESCAPE PLATFORM 2
REF. DWG.: -XG-831-4041

CURSOR ESCAPE PLATFORM DETAILS
REF. DWG.: -XG-831-4061

NOTES:

1. FOR GENERAL NOTES SEE: 2320000-UI-4020-N-XD-830-0001

REF. DRAWINGS:

DRAWING No.:	DRAWING NAME:
2320000-UI-4020-N-XD-831-0001	Cursor Secondary Steel - Sheet 1

Total Weight: 516 kg

REV	DATE	DESCRIPTION	PREPARED	CHECKED	DIS.CHECK	APPROVED
01	23-09-2024	Issued For Construction	DBa	EKe	FG	FD

Proprietary Rights, Intellectual Property and Confidentiality Notice.
Copyright 2021 UPTIME International AS. All right reserved.
This document contains and is intended to convey confidential and proprietary information which is the exclusive intellectual property of UPTIME International AS. This document, in electronic or hard copy format and any attachments included with or reference therein, MAY NOT by any means be reproduced, duplicated, distributed, shared, disclosed or used for any purpose without the express written permission of UPTIME International AS.

ENGINEERING AND FABRICATION:	PROJECT VESSEL DESIGN/ ID:
	BY151
SUB SUPPLIER:	CLIENT:
	Cochin Shipyard Ltd.

Project:	2320000 - Uptime 148	ALL DIMENSIONS IN mm U.N.O	
Title:	TELESCOPIC GANGWAY 30m 3.0 ELECTRIC CURSOR CURSOR ESCAPE PLATFORM ASSEMBLY - SHEET 1		
Drawing No.:	2320000-UI-4020-N-XG-831-4001	Vault Ref:	831-4001
Rev. No.:	01	Sub. No.:	01

BANK GUARANTEE TOWARDS EMD

To

COCHIN SHIPYARD LTD
(GOVT. OF INDIA ENTERPRISE,)
PO BAG No. 1653 , PERUMANOOR PO, COCHIN 682 015.

This deed of Guarantee made on Day ofTwo Thousandbetween CSL on one part and (Name and address of the bank) of the other part is as follows:

In consideration of CSL having allowed M/s.(herein after referred to as 'the Contractor') to submit Tender No.....without Earnest Money according to the conditions of such Tender Notification, we... (Name of the Bank) (hereinafter referred to as 'the bank') undertake to pay to CSL on demand the sum of money payable as Earnest Money in respect of the Tender Number.....made by the contractor in case the contractor withdraws from the tender before the date of firmness stipulated or when the tender is accepted by CSL, the contractor makes default in furnishing the Security Deposit or in entering into an agreement as required by CSL or otherwise commits any breach of the terms and conditions of the tender.

We, the bank, hereby irrevocably undertake to pay you any amount not exceeding in total the Guarantee Amount upon receipt by us of your demand in writing accompanied by the following documents:

Your signed statement certifying that the Contractor is in breach of his obligation(s) under the Contract and the respect in which the Contractor is in breach.

Any demand for payment should contain your authorized signatures which must be authorized by your bankers or by a notary public.

The guarantee shall remain in full force and effect during the period that would be taken for the finalization of the tender and till CSL certifies that the terms and conditions of the said tender have been fully and properly carried out by the said contractor and accordingly discharges this guarantee or for 6 months from the date of issue of this guarantee whichever is earlier. A notice of the claim under this guarantee may be served on the bank within 3 months after the said period in which case the same shall be enforceable.

We, the Bank, further agree that any change in the constitution of the said contractor or the said bank shall not discharge our liability hereunder. This guarantee shall not

be avoided, released or affected by any variation in the terms of the tender, acceptance of the contract between the contractor and CSL or any neglect, indulgence or forbearance by CSL.

Notwithstanding anything contained herein:

1. Our liability under this Bank Guarantee shall not exceed -----only).
2. This Bank Guarantee shall be valid up to (date) (9 months from the date of issuing the BG) and
3. We are liable to pay the guaranteed amount or any part thereof under this bank guarantee only and only if you serve upon us a written claim or demand on or before(validity date).

Any demand for payment under this Guarantee must be received by us at this office during working hours on or before the validity Date. Should we receive no claim from you by the validity Date, our liability to you will cease and the guarantee will definitely become null and void whether returned to us or not.

Yours truly,

Signature and seal of the guarantor:

Name of Bank:.....

Address:

Date:.....

**BANK GUARANTEE IN LIEU OF SECURITY DEPOSIT/WARRANTY
GUARANTEE**

To

COCHIN SHIPYARD LTD

(GOVT. OF INDIA ENTERPRISE,)

PO BAG No. 1653 , PERUMANOOR PO, COCHIN 682 015.

WHEREAS (Name & Address of Supplier) (hereinafter called "**the Supplier**") has undertaken, in pursuance of Contract.....

No..... Dated: to execute (Name of Contract and brief description of works) (hereinafter called "**the Contract**").

AND WHEREAS it has been stipulated by **COCHIN SHIPYARD LTD** (The Buyer - hereinafter called "**CSL**") in the said contract that the Supplier shall furnish **CSL** with a Bank Guarantee for the sum specified therein as security for compliance with the Supplier's obligations in accordance with the Contract.

AND WHEREAS we have agreed to give the Supplier such a Bank Guarantee.

NOW THEREFORE we (Name of the Bank) having its Head Office at

.....(Address of Head Office) and acting through its branch office at

..... (Address of the executing branch) (hereinafter called "**the Bank**")

hereby affirm that we are the Guarantor and responsible to **CSL**, on behalf of the Supplier up to a total of (amount of Guarantee)

.....in words).

We, the bank, hereby irrevocably undertake to pay you any amount not exceeding in total the Guarantee Amount upon receipt by us of your demand in writing accompanied by the following documents:

1. Your signed statement certifying that the Supplier is in breach of his obligation(s) under the Contract and the respect in which the Supplier is in breach.
2. Your signed statement certifying that the Supplier has been given a prior written notice by email from you to make good the aforesaid breach and that the Supplier still failed to fulfill the Contract within 30 days of such notice. A copy of such notice given by email to the Supplier shall be attached to the demand for payment.

Any demand for payment should contain your authorized signatures which must be authorized by your bankers or by a notary public.

We, the Bank, further agree that no change or addition to or other modification of the terms of the Contract or of the Works to be performed there under or of any of the Contract documents which may be made between **CSL** and the Supplier shall in any way release us from any liability under this guarantee, and we hereby waive notice of any such change, addition or modification. We, the Bank, further agree that any change in the constitution of the said contractor or the said bank shall not discharge our liability hereunder.

Notwithstanding anything contained herein:

1. Our liability under this Bank Guarantee shall not exceed
(..... only).
2. This Bank Guarantee shall be valid up to (date) and
3. We are liable to pay the guaranteed amount or any part thereof under this bank guarantee only and only if **CSL** serve upon us a written claim or demand on or before(validity date) .

Any demand for payment under this guarantee must be received by us at this office during working hours on or before the validity date. Should we receive no claim from you by the validity date, our liability to you will cease and the guarantee will definitely become null and void whether returned to us or not.

Yours truly,

Signature and seal of the

guarantor:.....

Name of Bank:.....

Address:

Date:.....

^[1] An amount shall be inserted by the Guarantor, representing the percentage of the Contract Price specified in the Contract and denominated in respective Dollars / Indian Rupees/Other Currency.

PRE CONTRACT INTEGRITY PACT

COCHIN SHIPYARD LIMITED

General

This pre-bid pre-contract Agreement (hereinafter called the Integrity Pact) is made on day of the month of, between Cochin Shipyard Ltd (CSL), A Government of India Enterprise under the Ministry of Ports, Shipping & Water Ways having its registered office at Cochin, Kerala, India (hereinafter called the “PRINCIPAL”) of the First part and M/s..... (hereinafter called the “BIDDER/Seller”) of the second part.

WHEREAS the PRINCIPAL proposes to procure and the BIDDER/Seller is willing to offer/has offered the stores and

WHEREAS the BIDDER is a private company / public company / Government undertaking / partnership/registered export agency, constituted in accordance with the relevant law in the matter and the PRINCIPAL is a Government of India Enterprise.

NOW, THEREFORE,

To avoid all forms of corruption by following a system that is fair, transparent and free from any influence/prejudiced dealings prior to, during and subsequent to the currency of the contract to be entered into with a view to:-

Enabling the PRINCIPAL to obtain the desired said stores/equipment/item at a competition price in conformity with the defined specifications by avoiding the high cost and the distortionary impact of corruption on public procurement, and

Enabling BIDDERS to abstain from bribing or indulging in any corrupt practice in order to secure the contract by providing assurance to them that their competitors will also abstain from bribing and other corrupt practices and the PRINCIPAL will commit to prevent corruption, in any form, by its officials by following transparent procedures.

The parties hereto hereby agree to enter into this Integrity Pact and agree as follows:-

Commitments of the PRINCIPAL

- 1.1 The PRINCIPAL undertakes that no official of the PRINCIPAL, connected directly or indirectly with the contract, will demand, take a promise for or accept, directly or through intermediaries, any bribe, consideration, gift, reward, favour or any material or immaterial benefit or any other advantage from the BIDDER, either for themselves or for any person, organization or third party related to the contract in exchange for an advantage in the bidding process, bid evaluation, contracting on implementation process related to the contract.

- 1.2 The PRINCIPAL will, during the pre-contract stage, treat all BIDDERS alike and will provide to all BIDDERS the same information and will not provide any such information to any particular BIDDER which could afford an advantage to that particular BIDDER in comparison to other BIDDERS.
- 1.3 The officials of the PRINCIPAL will report to the appropriate Government office any attempted or completed breaches of the above commitments as well as any substantial suspicion of such a breach.
- 2 In case any such preceding misconduct on the part of such official(s) is reported by the BIDDER to the PRINCIPAL with full and verifiable facts and the same is prima facie found to be correct by the PRINCIPAL, necessary disciplinary proceedings, or any other action as deemed fit, including criminal proceedings may be initiated by the PRINCIPAL and such a person shall be debarred from further dealings related to the contract process. In such a case while an enquiry is being conducted by the PRINCIPAL the proceedings under the contract would not be stalled.

3. Commitments of BIDDERS

The BIDDER commits itself to take all measures necessary to prevent corrupt practices, unfair means and illegal activities during any stage of its bid or during any pre-contract

or post-contract stage in order to secure the contract or in furtherance to secure it and in particular commit itself to the following:-

- 3.1 The BIDDER will not offer, directly or through intermediaries, any bribe, gift, consideration, reward, favour, any material or immaterial benefit or other advantage, commission, fees, brokerage or inducement to any official of the PRINCIPAL, connected directly or indirectly with the bidding process, or to any person, organization or third party related to the contract in exchange for any advantage in the bidding, evaluation, contracting and implementation of the contract.
- 3.2 The BIDDER further undertakes that it has not given, offered or promised to give, directly or indirectly any bribe, gift, consideration, reward, favour, any material or immaterial benefit or other advantage, commission, fees, brokerage or inducement to any official of the PRINCIPAL or otherwise in procuring the Contract or forbearing to do or having done any act in relation to the obtaining or execution of the contract of any other contract with the government for showing or forbearing to show favour or disfavor to any person in relation to the contract of any other contract with the Government.
- 3.3 BIDDERS of foreign origin shall disclose the name and address of their Indian agents and representatives, if any and Indian BIDDERS shall disclose their foreign principals or associates, if any, in the bid.
- 3.4 BIDDERS shall disclose the payments to be made by them to their Indian agents/brokers or any other intermediary, in connection with this bid/contract in the bid and the payments have to be in Indian Rupees only.

- 3.5** The BIDDER further confirms and declares to the PRINCIPAL that the BIDDER is the original manufacturer/ integrator/authorized agent of the stores/equipment/items and has not engaged any individual or firm or company whether Indian or foreign to intercede, facilitate or in any way to recommend to the PRINCIPAL or any of its functionaries, whether officially or unofficially to the award of the contract to the BIDDER, nor has any amount been paid, promised or intended to be paid to any such individual, firm or company in respect of any such intercession, facilitation or recommendation.
- 3.6** The BIDDER, either while presenting the bid or during pre-contract negotiations or before signing the contract, shall disclose any payments he has made, is committed to or intends to make to officials of the PRINCIPAL or their family members, agents, brokers or any other intermediaries in connection with the contract and the details of services agreed upon for such payments.
- 3.7** The BIDDER will not collude with other parties interested in the contract to impair the transparency, fairness and progress of the bidding process, bid evaluation, contracting and implementation of the contract.
- 3.8** The BIDDER will not accept any advantage in exchange for any corrupt practice, unfair means and illegal activities.
- 3.9** The BIDDER shall not use improperly, for purposes of competition or personal gain, pass on to others, any information provided by the PRINCIPAL as part of the business relationship, regarding plans, technical proposals and business details, including information contained in any electronic data carrier. The BIDDER also undertakes to exercise due and adequate care lest any such information is divulged.
- 3.10** The BIDDER commits to refrain from giving any complaint directly or through any other manner without supporting it with full and verifiable facts.
- 3.11** The BIDDER shall not instigate or cause to instigate any third person to commit any of the actions mentioned above.
- 3.12** If the BIDDER or any employee of the BIDDER or any person acting on behalf of the BIDDER, either directly or indirectly, is a relative of any of the officers of the PRINCIPAL, or alternatively, if any relative of an officer of the PRINCIPAL has financial interest/stake in the BIDDER's firm, the same shall be disclosed by the BIDDER at the time of filing of tender.

The term 'relative' for this purpose would be as defined in section 6 of the Companies Act 1956.

- 3.13** The BIDDER shall not lend to or borrow any money from or enter into any monetary dealings or transactions, directly or indirectly, with any employee or the PRINCIPAL.

4. Previous Transgression

- 4.1** The BIDDER declares that no previous transgression occurred in the last three years immediately before signing of this Integrity Pact, with any other company in any country in respect of any corrupt practices envisaged hereunder or with any Public Sector Enterprise in India or any Government Department in India that could justify; BIDDER's exclusion from the tender process.
- 4.2** The BIDDER agrees that if it makes incorrect statement on this subject, BIDDER can be disqualified from the tender process or the contract, if already awarded, can be terminated for such reason.

5. Earnest Money (Security Deposit)

- 5.1** While submitting commercial bid, the BIDDER shall deposit an amount **NIL** (to be specified in RFP) as Earnest Money as applicable/Security Deposit, with the PRINCIPAL through any of the following instruments:
- (i) Bank Draft of Pay Order in favor of CSL.
 - (ii) A confirmed guarantee by an Indian Nationalized Bank, promising payment of the guaranteed sum to the PRINCIPAL on demand within three working days without any demur whatsoever and without seeking any reasons whatsoever. The demand for payment by the PRINCIPAL shall be treated as conclusive proof of payment.
 - (iii) Any other mode or through any other instrument (to be specified in the RFP).
- 5.2** The Earnest Money if applicable/Security Deposit shall be valid upto the complete conclusion of the contractual obligations to the complete satisfaction of both the BIDDER and the PRINCIPAL, including warranty period.
- 5.3** In case of the successful BIDDER a clause would also be incorporated in the Article pertaining to Performance Bond in the Purchase Contract that the provisions of sanctions for Violation shall be applicable for forfeiture of Performance Bond in case of a decision by the PRINCIPAL to forfeit the same without assigning any reason for imposing sanction for violation of this Pact.
- 5.4** No interest shall be payable by the PRINCIPAL to the BIDDER on Earnest Money/Security Deposit for the period of its currency.

6 Sanctions for Violations

- 6.1** Any breach of the aforesaid provisions by the BIDDER or any one employed by it or acting on its behalf (whether with or without the knowledge of the BIDDER) shall entitle the PRINCIPAL to take all or any one of the following actions, wherever required:-

- (i) To immediately call off the pre contract negotiations without assigning any reason or giving any; compensation to the BIDDER. However, the proceedings with the other BIDDER(s) would continue.
- (ii) The Earnest Money Deposit (in pre-contract stage) and/or Security Deposit/ Performance Bond (after the contract is signed) shall stand forfeited either fully or partially, as decided by the PRINCIPAL and the PRINCIPAL shall not be required to assign any reason therefore.
- (iii) To immediately cancel the contract, if already signed, without giving any compensation to the BIDDER.
- (iv) To recover all sums already paid by the PRINCIPAL, and in the case of an Indian BIDDER with interest thereon at 2% above the prevailing Prime Lending Rate of State Bank of India, while in case of a BIDDER from a country other than India with interest thereon at 2% above the LIBOR (London Inter Bank Offer Rate). If any outstanding payment is due to the BIDDER from the PRINCIPAL in connection with any other contract for any other stores, such outstanding payment could also be utilized to recover the aforesaid sum and interest.
- (v) To encash the advance bank guarantee and performance bond/warranty bond, if furnished by the BIDDER, in order to recover the payments, already made by the PRINCIPAL, along with interest.
- (vi) To cancel all or any other contracts with the BIDDER. The BIDDER shall be liable to pay compensation for any loss or damage to the PRINCIPAL resulting from such cancellation/recession and the PRINCIPAL shall be entitled to deduct the amount so payable from the money(s) due to the BIDDER.
- (vii) To debar the BIDDER from participating in the future bidding processes of CSL for a minimum period as deemed appropriate, which any be further extended at the discretion of the PRINCIPAL.
- (viii) To recover all sums paid in violation of this Pact by BIDDER(s) to any middleman or agent or broker with a view to securing the contract.
- (ix) In cases where irrevocable Letters of Credit have been received in respect of any contract signed by the PRINCIPAL with the BIDDER, the same shall not be opened.
- (x) Forfeiture of Performance Bond in case of a decision by the PRINCIPAL to forfeit the same without assigning any reason for imposing sanction for violation of this pact.

6.2 The PRINCIPAL will be entitled to take all or any of the actions mentioned at para 6.1(i) to (x) of this pact also on the Commission by the BIDDER or any one employed by it or acting on its behalf (whether with or without the knowledge of the BIDDER), of an offence as defined in chapter IX of the Indian Penal code, 1860 or Prevention of Corruption Act, 1988 or any other statute enacted for prevention of corruption.

6.3 The decision of the PRINCIPAL to the effect that a breach of the provisions of this pact has been committed by the BIDDER shall be binding on the BIDDER. However, the BIDDER can approach the Independent Monitor(s) appointed for the purposes this Pact.

7 **Fall Clause**

7.1 The BIDDER undertakes that it has not supplied/is not supplying similar product/systems/items or subsystems at a price lower than that offered in the present bid in respect of any other Ministry/Department of the Government of India or PSU and if it is found at any stage that similar product/systems or sub systems/items was supplied by the BIDDER to any other Ministry/Department of the Government of India or PSU at a lower price, then that very price, with due allowance for elapsed time, will be applicable to the present case and the difference in the cost would be refunded by the BIDDER to the PRINCIPAL, if the contract has already been concluded.

8 **Independent Monitor**

8.1 The PRINCIPAL has appointed Independent Monitor (hereinafter referred to as Monitor) for this Pact in consultation with the Central Vigilance Commission.

Dr. Vinod Bihari Mathur, IFoS (Retd.)
D302, Arborea Luxury Homes,
Tarla Nagal, Near Doon Helidrome,
Dehradun, Uttarakhand - 248001
Mobile: 9412054648
Email: vbm.ddn@gmail.com

8.2 The task of the Monitor shall be to review independently and objectively, whether and to what extent the parties comply with the obligations under this Pact.

8.3 The Monitor shall not be subject to instructions by the representatives of the parties and perform their functions neutrally and independently.

8.4 Both the parties accept that the Monitor has the right to access all the documents relating to the project/procurement, including minutes of meetings.

8.5 As soon as the Monitor notices, or has reason to believe, a violation of this pact, he will so inform the Authority designated by the PRINCIPAL.

8.6 The PRINCIPAL accepts that the Monitor has the right to access without restriction to all Project documentation of the BUYER including that provided by the BIDDER. The BIDDER will also grant the Monitor, upon his request and demonstration of a valid interest, unlimited access to his project documentation. The same is applicable to Subcontractors. The Monitor shall be under contractual obligation to treat the information and documents of the BIDDER/Subcontractor(s) with confidentiality.

8.7 The PRINCIPAL will provide to the Monitor sufficient information about all meetings among the parties related to the Project provided such meetings could have an impact on the contractual relations between the parties. The parties will offer to the Monitor the option to participate in such meetings.

8.8 The Monitors will submit a written report to the designated Authority of PRINCIPAL /Secretary in the Department/ within 8 to 10 weeks from the date of reference or intimation to him by the PRINCIPAL /BIDDER and, should the occasion arise, submit proposals for correcting problematic situations.

9 Facilitation of Investigation

In case of any allegation of violation of any provisions of this pact or payment of commission, the PRINCIPAL or its agencies shall be entitled to examine all the documents including the Books of Accounts of the BIDDER. The BIDDER shall provide necessary information and documents in English and shall extend all possible help of the purpose of such examination/inspection.

10 Law and Place of Jurisdiction

10.1 This Pact is subject to Indian Law. The place of performance and jurisdiction is the seat of the PRINCIPAL.

10.2 A person signing Integrity Pact shall not approach the Courts while representing the matters to Independent External Monitor and shall await their decision in the matter.

11 Other Legal Actions

The actions stipulated in this Integrity Pact are without prejudice to any other legal action that may follow in accordance with the provisions of the extent law in force relating to any civil or criminal proceedings.

12 Validity

12.1 The validity of this Integrity Pact shall be from date of its signing and extend upto 5 years or the complete execution of the contract to the satisfaction of both the PRINCIPAL and the BIDDER/Seller, including warranty period, whichever is later. In case BIDDER is unsuccessful, this Integrity Pact shall expire after six months from the date of the signing of the contract.

12.2 Should one or several provisions of this Pact turn out to be invalid; the remainder of this pact shall remain valid. In this case, the parties will strive to come to an agreement to their original intentions.

13 The parties hereby sign this Integrity Pact aton

For & on behalf of PRINCIPAL
Cochin Shipyard Limited
(Office Seal)

For & on behalf of BIDDER
(Office Seal)

Witness

Witness

1.....
2.....

1.....
2.....

* Provisions of these clauses would need to be amended/deleted in line with the policy of the BUYER in regard to involvement of Indian agents of foreign suppliers.