



हुगली कोचीन शिपयार्ड लिमिटेड
(भारत सरकार का उद्यम)
HOOGHLY COCHIN SHIPYARD LIMITED
(A Govt. of India Enterprise)



वसुधैव कुटुम्बकम्
ONE EARTH • ONE FAMILY • ONE FUTURE

Tender No: HCSL/OPS/SB/TEN/037/2024-25

Date: 22.07.2024

NOTICE INVITING TENDER

Competitive Offers are invited on behalf of Hooghly Cochin Shipyard Limited (HCSL) for the under mentioned work, so as to reach the undersigned on or before the date and time mentioned below. Please refer technical specification, General Terms and Conditions as attached.

Tender No. & date	HCSL/OPS/SB/TEN/037/2024-25, Dt.- 22.07.2024
Scope of work	Supply of materials for Sealing Arrangement of Cargo Hatch Cover for JAK 2200T MPV Vessels at Hooghly Cochin Shipyard Limited, Nazirgunge Unit, Howrah.
Type of Tender	Two Bid
Cost of tender form	NIL
Earnest Money Deposit (EMD)	Rs. 50,000/-
Last date & time of receipt of tender	12.08.2024 at 15:00 Hrs.
Date & time of opening of technical bid	12.08.2024 at 15:30 Hrs.
Tenure of contract	Within 30 Days (from the date of issuance of Purchase Order).
Officer - in - Charge	Name: Simmi Kumari Designation: ET(Electrical) Email: simmi.kumari@cochinshipyard.in Phone No: +91 6370543149 Name: Girish Gupta Designation: Asst. Manager (Materials) Email: girish.gupta@hooghlycsl.com Phone No: +91 8085278430 Name: Saikat Biswas Designation: Dy. Manager (Materials) Email: saikat.biswas@hooghlycsl.com Phone No: +91 8250792208



Registered Office: Administrative Building, HCSL Premises, Satyen Bose Road,
P.O. Danesh Shaikh Lane, Nazirgunge, Howrah, West Bengal - 711 109.
☎ +91 (33)-2888 8282 ✉ contact@hooghlycsl.com 🌐 www.hooghlycsl.com

Shipyard: Nazirgunge Unit, Satyen Bose Road, P.O. Danesh SK Lane,
P.S. Sankrail, Howrah, West Bengal - 711109
☎ +91 (33)-2955 8283

CIN : U35900WB2017GOI223197. GSTIN : 19AAECH3640L1ZD

Simmi
SG



हुगली कोचीन शिपयार्ड लिमिटेड
(भारत सरकार का उद्यम)
HOOGHLY COCHIN SHIPYARD LIMITED
(A Govt. of India Enterprise)



वसुधैव कुटुम्बकम्
ONE EARTH • ONE FAMILY • ONE FUTURE

Tender to be submitted by email only. Tender reference should be clearly indicated on the subject of the Mail.

Tenders should be submitted in two separate files as **PART-I "TECHNO-COMMERCIAL" & PART-II "PRICE" (Password Protected)** indicating the tender number, due date of the tender in the Mail and addressed to The Assistant General Manager (Material), Hooghly Cochin Shipyard Limited, Nazirgunge Unit, Howrah.

For Hooghly Cochin Shipyard Limited

Signature and Seal of the Bidder(s)



Registered Office: Administrative Building, HCSL Premises, Satyen Bose Road,
P.O. Danesh Shaikh Lane, Nazirgunge, Howrah, West Bengal - 711 109.
☎ +91 (33)-2688 8282 ✉ contact@hooghlycsl.com 🌐 www.hooghlycsl.com

Shipyard: Nazirgunge Unit, Satyen Bose Road, P.O. Danesh SK Lana,
P.S. Sanikraill, Howrah, West Bengal - 711109
☎ +91 (33)-2955 8283

CIN : U35900WB2017GD1223197. GSTIN : 19AAECH3640L1ZD

Tender administration: Tender procedure/administration/evaluation including correspondences and awarding of contract will be done by M/s. Hooghly Cochin Shipyard Limited, Howrah, West Bengal.

Officer - in - Charge for the above work:

Name: Simmi Kumari

Designation: ET(Electrical)

Email: simmi.kumari@cochinshipyard.in

Phone No: +91 6370543149

Name: Girish Gupta

Designation: Asst. Manager (Materials)

Email: girish.gupta@hooghlycsl.com

Phone No: +91 8085278430

Name: Saikat Biswas

Designation: Dy. Manager (Materials)

Email: saikat.biswas@hooghlycsl.com

Phone No: +91 8250792208

For any technical queries:

Name: Rakesh Kumar Sagar

Designation: Manager (NA)

Email: rakesh.kumar@hooghlycsl.com

Phone No: +91 9508921575

For Hooghly Cochin Shipyard Limited

TABLE OF CONTENTS

Sl. No.	Description	Annexure
1.	Technical Specification	Annexure-1
2.	Price Bid Format	Annexure-2
3.	Instruction to bidders	Annexure-3
4.	General Terms & Conditions	Annexure-4
5.	Restriction of bidders sharing land border with India	Annexure-5
6.	List of Deviations	Annexure-6
7.	NEFT Mandate Form	Annexure-7
8.	SD/ Bank Guarantee Format	Annexure-8
9.	Tender condition- Preference to Make in India	Annexure-9
10.	Vendor details	Annexure-10
11.	Form of Self Declaration	Annexure-11
12.	Form of Legal Cases	Annexure-12

For **Hooghly Cochin Shipyard Limited**

Signature and Seal of the Bidder(s)

Technical Specification**GENERAL CONDITIONS FOR SUPPLY OF RUBBER SEALING ARRANGEMENT FOR 2200 T MULTI PURPOSE VESSEL**

1. REQUIREMENT

Supply of material for Sealing Arrangement of Cargo Hatch Cover as listed below for 2200T MPV

SL. No.	Description	Size	Qty
1	Neoprene Rubber (Shore Hardness-55 ⁰)	75 x 10 thk (Width x Thickness)	150 RM
2	Neoprene Rubber (Shore Hardness-55 ⁰)	425 x 500 x 10 thk	40 Nos.
3	Neoprene Rubber (Shore Hardness-55 ⁰)	195 x 10 thk (Width x Thickness)	35 RM
4	Neoprene Rubber (Shore Hardness-55 ⁰)	500 x 75 x 60 thk	18 Nos.
5	Neoprene Rubber (Shore Hardness-55 ⁰)	95 x 10 thk (Width x Thickness)	90 RM
6	Neoprene Rubber (Shore Hardness-55 ⁰)	2 M Length (as per Drg)	10 Nos.
7	Neoprene Rubber (Shore Hardness-55 ⁰)	3 M Length (as per Drg)	25 Nos.
8	GI Countersunk Bolt (Grade 4.6)	M8 x 20	800 nos.
9	GI Countersunk Screw (Grade 4.6)	M8 x 50	100 Nos.
10	GI Washer	M8	900 Nos.
11	GI Bolt (Grade 4.6)	M16 x 135	400 Nos.
12	GI Washer	M16	800 Nos.
13	GI NUT(Grade 4.6)	M16	400 Nos.

2. VESSEL

2.1. Type of vessel:

The vessel will have one cargo hold. The ship will be propelled by a medium speed, four-stroke diesel engine, through a reduction gearbox and fixed pitch propeller (FPP).

The vessel will be arranged and equipped for the carriage of, project cargo, steel coils, containers, dry cargoes and bulk cargoes such as coal, grain and dangerous goods on world-wide service trade.

2.2. Classification/Rules & Regulations

The vessel shall be designed and constructed under supervision and in accordance with the regulations of IRS for the classification mark:

☒ SUL, "INDIAN RIVER SEA VESSBL - TYPE 4", 'Equipped for Carriage of Containers"

☒ IY "General Cargo Vessel

2.3. Particulars of the Vessel:

Length overall (approx.)	:	78.00 m (max)
Beam Moulded (max)	:	16.00 m (max.)
Depth Moulded	:	5.50 m (approx.)
Speed	:	10.0 knots
Deadweight	:	2200 T The material used for hull is Steel IRS GR-A,

3. RULES AND REGULATIONS

Vessel shall be built in compliance with all relevant International Standards as applicable at the time of construction, including (but not limited to) the following.:

The "Rules and Regulations for the Construction and Classification of Steel Ships, July, 2022" and IRS Classification Notes: Application of IRS Rules to Indian River Sea Vessels - Apr 2021. hereinafter referred to as RULES. The RULES form an integral part of this tender.

The following National/International Codes & Conventions, Regulations and interpretations by the Flag administration that are in force at the time of the keel laying date or similar stage of construction, hereinafter referred to as REGULATIONS:

- International Convention on Tonnage Measurement of Ships, 1969, as amended
- International Convention of Load line 1966 and protocol of 1988
- M.S (Tonnage Measurement of Ships) Rule, 1987 as amended

- IS Code 2008
- DGS Order No. I 8 of 201 3 - Notification for Construction, Survey, Certification and Operation of Indian River Sea Vessel- Type 1,2,3 &4
- IMO Resolution A.714(17) - Code of Practice for Cargo Stowage and Securing.
- EEDI - MEPC 308 (73), as amended by resolutions MEPC.322(74) and MEPC.332(76)
- IMSBC Code
- IMDG Code
- Merchant Shipping (Control of Anti- fouling System) Rule 2016

4. TECHNICAL SPECIFICATION OF CARGO FITTINGS

A. REQUIREMENTS OF SEALING ARRANGEMENT OF HATCH COVER

- 1) Items shall be manufactured with reference to the requirements and conditions stated in this technical specification
- 2) All fittings are to be designed and fabricated as per requirements.

B. DETAILS OF NEOPRENE RUBBER

- 1) Items shall be manufactured with reference to the requirements and conditions stated in this technical specification
- 2) The shore Hardness of the Neoprene Rubber shall be 55⁰
- 3) Supply of GI bolt , nut and washer shall be electroplated as per IS 1367 (part 11)
- 4) Grade of Bolt, Nut & Washer shall be 4.6
- 5) For Sl No. 6 & 7 making hole on sealing neoprene rubber is in contractor scope

5. SUPPLY OF DOCUMENTS

Detailed drawings indicating size and material of each item shall be furnished along with the offer. All documents shall be in English and in Metric system and the following documents shall be submitted, where applicable.

- I. Documents/Certificates to be supplied with the material (3 sets unless otherwise mentioned).
 - a. Detailed Packing list.
 - b. The manufacturer shall supply a manufacturer certificate of test both rubber and GI Bolt, Nut & Washer

6. MISCELLANEOUS

- a. Manufacturer while quoting should provide the cost of item separately.

- b. Preservation: Recommended method of preservation and names of recommended preservatives shall be indicated. Preservative required for two years storage in the yard shall be supplied with the item. (Relative humidity at Kolkata is around 70%).

7. GUARANTEE

As per HCSL commercial terms and conditions.

8. Place of Delivery:

Hooghly Cochin Shipyard Ltd (HCSL)
Satyen Bose Road, Danesh Sk. Lane (PO)
Nazirgunge, Howrah
West Bengal, PIN -711109
India.

Drawing for Sl. No. 6 (2M Length Neoprene Rubber)

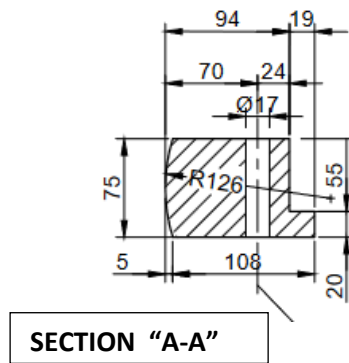
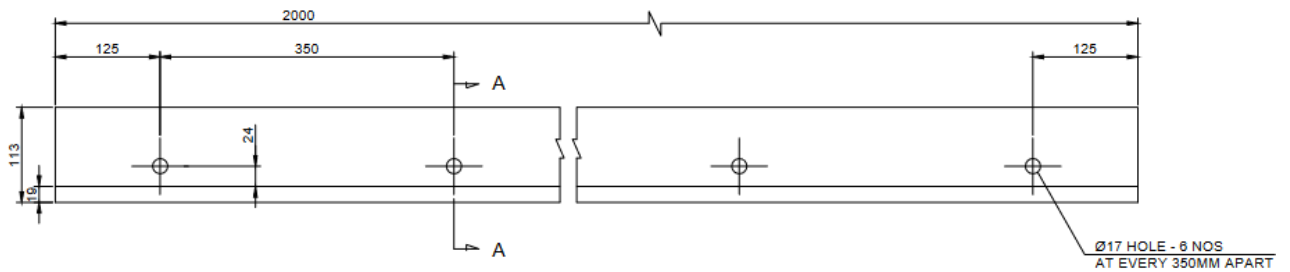

Drawing for Sl. No. 7 (3M Length Neoprene Rubber)

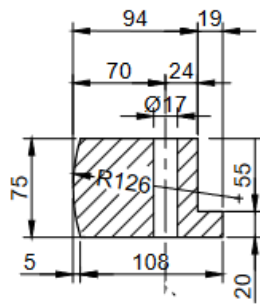
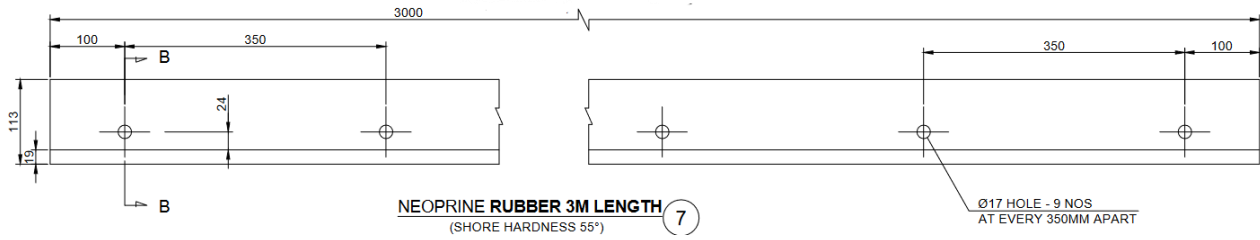

SECTION "B-B"

Price Bid Format

Procurement of materials for Sealing Arrangement of Cargo Hatch Cover for JAK 2200T MPV Vessels at Hooghly Cochin Shipyard Limited, Nazirgunge Unit, Howrah								
Sl. No	Material Description (Scope of Supply)	Size	Qty	UOM	Unit Rate (INR)	Amount (Without GST) (INR)	GST Amount (INR)	Total Amount (Including GST) (INR)
			(A)	(B)	(C)	(D)=(A)*(C)	(E)	(F)= (D)+(E)
1	Neoprene Rubber (Shore Hardness-55 ⁰)	75 x 10 thk (Width x Thickness)	150	RM				
2	Neoprene Rubber (Shore Hardness-55 ⁰)	425 x 500 x 10 thk	40	Nos.				
3	Neoprene Rubber (Shore Hardness-55 ⁰)	195 x 10 thk (Width x Thickness)	35	RM				
4	Neoprene Rubber (Shore Hardness-55 ⁰)	500 x 75 x 60 thk	18	Nos.				
5	Neoprene Rubber (Shore Hardness-55 ⁰)	95 x 10 thk (Width x Thickness)	90	RM				
6	Neoprene Rubber (Shore Hardness-55 ⁰)	2 M Length (Drg. attached)	10	Nos.				
7	Neoprene Rubber (Shore Hardness-55 ⁰)	3 M Length (Drg. attached)	25	Nos.				
8	GI Countersunk Bolt (Grade 4.6)	M8 x 20	800	Nos.				
9	GI Countersunk Screw (Grade 4.6)	M8 x 50	100	Nos.				
10	GI Washer	M8	900	Nos.				

11	GI Bolt (Grade 4.6)	M16 x 135	400	Nos.					
12	GI Washer	M16	800	Nos.					
13	GI NUT (Grade 4.6)	M16	400	Nos.					
14	Total Amount without GST (INR)								
15	Total GST Amount (INR)								
16	Total Amount Including GST (INR)								
17	Total Amount Including GST (IN WORDS)								

NOTE: Price Bid Instructions

1. Quoted items should comply with the technical specification as per Annexure-I.
2. Quotation for all line items is mandatory. Partially quoting for few line items shall result in rejection of the bid.
3. Price to be quoted in INR only.
4. Quoted rate should be FOR HCSL stores basis inclusive of all charges considering entire Scope of Work, Technical Specification, transportation & delivery Charges, if any, also should be included in Unit Rate and not to be mentioned as a separate line item.
5. Price Bid to be submitted strictly as per format. Modifying the format will result in rejection of the bid.
6. L1 Bidder will be evaluated based on the combined cost of all the items excluding GST.

Important Note:

1. Un-priced Bid, to be submitted along with techno commercial bid with details showing whether “Amount quoted/ Nil/ Included “against respective column.

Signature and Seal of the Bidder

SPECIAL INSTRUCTION TO BIDDER

1. MODE OF SUBMISSION OF TENDERS

Tenders should be submitted in two separate files as **PART-I"TECHNO-COMMERCIAL" & PART-II "PRICE" (Password Protected)** indicating the tender number, due date of the tender in the subject of the Mail and addressed to The Assistant General Manager (Materials).

2. TECHNO-COMMERCIAL PART SHOULD CONTAIN FOLLOWING DETAILS: -

- I. Specification & Technical Literature, if any.
- II. Other conditions, if any
 - a. Signed and stamped copy of Scope of supply & Technical Specification (Annexure-1)
 - b. Unquoted Price bid (Annexure-2)
 - c. Special Instruction to Bidder (Annexure-3)
 - d. General Terms and Conditions (Annexure-4)
 - e. Restriction of bidders sharing land border with India (Annexure-5)
 - f. Deviation List (Annexure-6), if any.
 - g. SD/Bank guarantee format. (Annexure-8)
 - h. Make in India (Annexure-9)
 - i. Vendors details (Annexure-10)
 - j. Self-Declaration Annexure-11)
 - k. Details of Legal Case pending (Annexure-12), if any
 - l. Product Specification, detail list of supplied items including brand name and accessories etc., to be provided for verification.

3. PRICE PART SHOULD CONTAIN FOLLOWING DETAILS: -

- a. Price against item.
- b. Taxes & duties as applicable shall be indicated.

Note:

- i. Modification or alteration of the price bid format attached is strictly prohibited. Otherwise Bid will be liable for rejection.
- ii. In case Price bid is placed inadvertently in the Techno-Commercial Part or in case Price bid is not password protected, Bid will be straightway rejected.

4. While submitting the bid, bidders are requested to note that the e-mail ID starting with following words may probable be treated as spam, not always necessary- info, support, admin, sales, customer support, helpdesk, mail, mailadmin, billing, hello, careers.

Bidders are requested to submit the bid by e-mail (Price part password protected) only to all three the following email address clearly mention the tender reference in the subject line for easy identification.

simmi.kumari@cochinshipyard.in

girish.gupta@hooghlycsl.com

saikat.biswas@hooghlycsl.com

5. The Techno-commercial part alone will be opened initially on the due date and time of tender. The price part will be opened only after evaluation of the Techno commercial part. Bidders will be intimated the date of opening of the price part, whose techno-commercial bids are acceptable in due course. Password of price bid will require to be shared at the time of price bid opening.
6. Deviations, if any, in the offer submitted from that of the tender enquiry in any form, should be clearly furnished in a separate document titled as “List of Deviations”.
7. After submission of quotation / price bid opening, no unsolicited correspondence will be entertained.
8. Clarifications, either technical or commercial, should be submitted to points specially asked for only. The opportunity so given should not be used for correcting/changing amending the data/conditions already submitted with the tender.
9. Offers should be clear and unambiguous. Incomplete/ambiguous offers are likely to be rejected.
10. The bidder shall submit a signed & stamped copy of the tender document including Annexures and Enclosures along with their bid as token of acceptance of terms & Conditions.

For Hooghly Cochin Shipyard Limited

Minimum Pre- qualification criteria for participating in the tender will be as follows:

- i. Successful experience as Supplier for similar material supply within the last **2 years** ending last day of month previous to the one in which applications are invited. (Satisfactory completion certificate from the Client for work done should be submitted along with bid).

Similar Supply means: Supply of neoprene rubber materials for State/Central Govt., Shipyards, MNCs or similar etc. within the respective years ending last day of month previous to one in which applications are invited.

- ii. Audited Balance sheets showing turnover, Profit & Loss account of the firm for the preceding 03 financial years should be submitted along with the application for prequalification.
- iii. The Tenderer should enclose copy of PAN, GST registration certificate, Income tax returns for last three Financial Year.
- iv. Offers from joint ventures/consortium will not be accepted.
- v. Net worth of the bidder must be positive as per the latest balance sheet. (MSME/NSIC will get exemptions)

GENERAL TERMS AND CONDITIONS

Sl No.	Description	Compliance by Supplier (YES/NO) In case of non-compliance, please provide remarks
1.	Tenderers are to carefully go through the terms and conditions and the technical specification of the items for which offers are called for. Tenderers have to adhere to above and supply full technical scope of items along with compliance of commercial conditions. HCSL have full right upon deviations, if any, including rejecting the partial scope/ complied offers.	
2.	Offers are to be free from overwriting. Corrections and additions, if any, must be attested. The offers shall be submitted only through email. Incomplete/ambiguous/conditional offers are likely to be rejected.	
3.	Bidders can contact Officer-in-charge of the work which is indicated in the Tender Notice for any clarification before submitting the offer. If clarifications/details are not obtained before the offer is submitted, no claim on this account will be admitted.	
4.	Technical checklist, if applicable and current general terms & conditions of enquiry duly filled and signed and technical specifications of items offered, should be submitted along with part-1 techno-commercial bid. Non receipt of the document may lead to rejection of offers.	
5.	SPECIFICATIONS: - a) Manufacturer's name, their trade mark and brand, if any, should invariably be mentioned and illustrative leaflets giving technical particulars (technical details of items offered including technical literature) etc., should be attached to the offer.	
	b) Materials offered shall conform to HCSL specifications.	
6.	Packing materials should be eco-friendly.	
7.	Supplier should follow the statutory requirements of product offered.	
8.	Products supplied shall be nontoxic and harmless to health. In case of toxic materials, Materials Safety Data Sheet may be furnished along with the material.	
9.	Taxes and duties, if any, payable extra are to be indicated in the price part.	

10.	<p>Delivery time required for supplies should be indicated in the offer (including time frame for manufacture, transportation, delivery etc.).</p> <p>Delivery: Delivery Period is 30 days from the date of issuance of PO/LOI. Delivery period shall be clearly indicated in the technical bid. <u>HCSL reserves the full right to accept/reject any offer based on the delivery period</u></p> <p>Items to be delivered at following address:</p> <p>Hooghly Cochin Shipyard Ltd (HCSL), Satyen Bose Road, Danesh Sk. Lane (PO), Nazirgunge, Howrah, West Bengal, PIN -711109.</p>	
11.	<p><u>PAYMENT TERMS:</u></p> <p>I) HCSL payment term is 100% with applicable taxes within 30 days from the date of receipt and acceptance of all items/vessel as per tender at HCSL stores after inspection.</p> <p>II) The invoice shall be compliant with GST Law. (ii) GST liability is to be discharged and ensure filing of outward supply details on GSTN portal within timeline prescribed. (Covered under GST Terms and Condition at (B)) (iii) Any debit note/supplementary invoice if any, is to be raised within September month following the respective financial year or filing of annual return by HCSL, whichever is earlier. (iv) Any loss of tax credit due to the reason attributable to supplier shall be recovered from supplier along with Applicable interest and penalty.</p> <p>III) Payment mode shall be Electronic Clearing System (ECS)/cheque /NEFT/ LC/CAD/TT as mutually agreed in line with above standard payment terms. Variations from standard terms, if any, shall be appropriately loaded for tender comparison purposes for arriving the lowest bid.</p> <p>IV) Bidders to note that no advance payment will be made by HCSL against work order issued.</p> <p>V) The Prices offered should remain firm till the completion of delivery, in case the purchase order is placed with you.</p> <p>VI) Delivery of material at HCSL store including freight & insurance charges.</p>	
12.	<p><u>Earnest Money Deposit (EMD):</u> Tenderers participating in tender shall deposit an amount of Rs. 50,000/- as Earnest Money Deposit (EMD) for participation against individual schedule along with the tender.</p> <p>a) The EMD can be remitted in the form of Demand Draft (DD) / Banker's Cheque / Fixed Deposit Receipt (FDR)/ Bank Guarantee</p>	

	<p>drawn in favour of 'Hooghly Cochin Shipyard Ltd. payable at Kolkata and shall be valid for a period of 6 (Six) months from the due date of opening of Techno-commercial Bids from any Nationalized/ Scheduled Bank or paid online through e-gateway of -</p> <p style="text-align: center;">UNION BANK OF INDIA SHIBPPUR BRANCH ACCOUNT NO: 756905010000104 IFSC CODE: UBIN0575691</p> <p>b) EMD furnished by all manufacturers except the lowest tenderer will be released after issuing work order and its acceptance by the contractor to whom the work is awarded.</p> <p>c) EMD of the successful tenderer will be refunded after remittance of the security deposit and execution of the agreement.</p> <p>d) EMD deposited with the Client will be forfeited,</p> <p>i) if a bidder withdraws or modifies his bid during the period of validity specified or</p> <p>ii) if the successful bidder fails within the time limit to sign the agreement document or fails to furnish the required security deposit.</p> <p>iii) Request for enhancement in the quoted rates or bringing in new conditions after tender opening or unnecessary delayed acceptance of the order / commencement of work / submission of Security Deposit. The relevant documents pertaining to the proof of submission of EMD should be enclosed along with techno-commercial bid.</p> <p>TENDERS RECEIVED WITHOUT EMD WILL NOT BE CONSIDERED AT ALL FOR FURTHER EVALUATION.</p>	
13.	<p><u>a) Security Deposit:</u></p> <p>i) The successful bidder shall remit a security deposit of 3% of the total order value (excluding taxes, duties etc.) in the form of demand draft drawn in favor of Hooghly Cochin Shipyard Ltd. towards the satisfactory performance of the contract, if an order is placed on them. Alternatively, a Bank Guarantee equivalent to above % of the total order value (excluding taxes, duties) as per HCSL format from Scheduled Indian bank for Indian supplier can be submitted, if an order is placed towards satisfactory performance of the contract.</p> <p>iii) The Bank Guarantee /DD as above should be valid till 90 days after completion of supplies in terms of SD.</p> <p>(iii) Fixed Deposit Receipt (for equivalent amount of Security Deposit/BG required as per tender) in lieu of bank guarantee is also acceptable. Fixed Deposit Receipt shall be in the name of supplier with lien marked in favor of Hooghly Cochin Shipyard Limited, Kolkata.</p> <p>b) SD to be submitted within 2 weeks of receipt of order from yard.</p>	

	c) Format of bank guarantee along with enquiry to be agreed. Placed at Annexure-8.	
	d) The above SD is required or applicable only when the total order value (excluding taxes and duties) is Rs.20 lakhs and above.	
	e) If the bidder is not agreeable to submission of SD as per HCSL general terms and conditions of enquiry, HCSL reserves the right to reject the offer at our discretion or 3% of total order value (excluding taxes and duties) will be added to the quoted price for tender comparison/ evaluation purpose on case-to-case basis for arriving the lowest bid.	
14.	Risk Purchase: If the supplier fails to supply the items ordered in good quality as per contract specification and fails to deliver within the delivery date or violate any of the terms and conditions of the purchase order, HCSL shall have the following rights.	
	a. To cancel the order partially or full with 15 days' notice and to forfeit the security deposit, if any.	
	b. To impose tender holiday for the vendor for an appropriate period as decided by HCSL.	
	c. To initiate alternate procurement action at the risk and cost of the supplier. This clause is applicable only in the case of total order/ contract value (excluding taxes and duties) is Rs.20 lakhs and above (or equivalent foreign currency). Cases of value less than 20 lakhs will be addressed by serving appropriate caution/ warning notice to the firm.	
15.	<u>Liquidated Damage:</u> In case of delay in supply of ordered materials beyond the stipulated delivery period, which is not attributable to HCSL, supplier is to pay Liquidated Damages (and not by way of penalty) a sum equivalent to ½% (half percent) per week or part of the week of the total basic price of material delayed, subject to a maximum of 10% of the total basic price of undelivered material. (Total basic price is the order value excluding freight, taxes, other charges etc.) However, LD applicability is without prejudice to HCSL right to terminate contract for delayed delivery or other actions as per Risk Purchase clause.	
16.	<u>Warranty/Guarantee</u> a) The Items supplied shall be guaranteed for rated performance and against damage or failure due to faulty design, defective materials and bad workmanship for a period from delivery of items until 12 months from the date of delivery of the ship to Owners OR 24 months from delivery of items to Yard, whichever is earlier. Should such damage/failure occur within the Guarantee period, the Supplier should immediately rectify the failure by repair/replacement of any such part found to be under performing/ defective, at his own expenses.	

	b) Further to equipment guarantee, replaced/repaired items shall be guaranteed for 12 months from date of repair/replacement.	
17.	<p><u>Jurisdiction:</u> All questions, disputes or difference arising under, out of, or in connection with contracts shall be subject to the exclusive jurisdiction of the Courts at Kolkata, West Bengal, India. Alternate dispute resolution mechanism can also be considered.</p>	
18.	<p><u>Force Majeure condition:</u> Should failure in performance of the contract or part thereof arise from war insurrection, restraint imposed by Government, Act of Legislature or other Statutory Authority or illegal strike, riot, legal lock-out, flood, fire, explosion, act of God or any inevitable or unforeseen event beyond human control which may be construed as reasonable ground for an extension of time, HCSL may allow such additional time as is mutually agreed, to be justified by the circumstances of the case.</p> <p>The occurrence/cessation of force majeure situation is to be informed with documentary evidence within 15 days from the date of occurrence/ cessation.</p>	
19.	Clarifications, either technical or commercial, should be submitted to points specially asked for only. The opportunity so given should not be used for correcting/changing/amending the data/conditions already submitted with the tender	
20.	<p><u>PRICING:</u> All applicable taxes, duties if any etc should be included in the rate quoted, unless specified otherwise. HCSL reserves the right for the deduction of taxes and duties as applicable from the bill or invoice.</p> <p>Bidder should quote prices for delivery of materials at HCSL store.</p> <p>Address: Hooghly Cochin Shipyard Ltd (HCSL), Satyen Bose Road, Danesh Sk. Lane (PO), Nazirgunge, Howrah, West Bengal, PIN -711109.</p> <p>Insurance for transit shall be arranged by the vendor.</p>	
	Firm shall quote in INR only	
	Comparison of prices will be in INR only	
21.	<u>Validity:</u> a. Prices should be valid for acceptance for a period of two months from the date of tender opening.	

	<p>b. No enhancement of rate for whatsoever cause will be allowed once the offer is accepted and an order is placed. Withdrawal of the quotation after it is accepted or failure to make the supply within the stipulated delivery period, will entail cancellation of the order and forfeiture of Earnest Money Deposit/Security deposit, if any and/or risk purchase, without prejudice to other penal actions, including tender holiday after serving show cause notices, as deemed fit.</p>	
22.	<p>Conditional discounts, if any, will not be reckoned for tender evaluation/ comparison purpose. However, if the bidder becomes L1 at original offer, conditional discount shall also be considered.</p>	
23.	<p>Unpriced bid (price bid without price) duly signed is to be submitted along with techno-commercial offer in the price format, provided. Price should be quoted separately for each item shown in the format. In the event price bid is different from the unpriced format already submitted, yard reserves the right to reject the offer at our discretion without any further discussions. Details of optional items, if any, should be indicated under separate heading in the Techno commercial bid and the respective price details should also be given in the price bid. Combining of figures against more than one item and ambiguous clauses will lead to rejection of the bid.</p>	
24.	<p>If, in the price structure quoted for the required material/ item, there is discrepancy between the unit price and the total price (which is obtained by multiplying the unit price by the quantity), the unit price shall prevail and the total price corrected accordingly. If there is an error in a total corresponding to the addition or subtraction of subtotals, the subtotals shall prevail and the total shall be corrected. If there is a discrepancy between words and figures, amount in words of respective figures shall prevail. If the bidder does not agree to the observation of the HCSL, the tender is liable to be rejected and the same shall be intimated.</p>	
25.	<p>After submission of quotation/price offer no unsolicited correspondence will be entertained.</p>	
26.	<p>Hooghly Cochin Shipyard Limited does not bind itself to accept the lowest or any tender but reserves to itself the right to reject any or all or a part of any tender at its discretion.</p>	
27.	<p>L1 computation shall be based on total cost of all items including (excluding GST).</p>	
28.	<p>SUB CONTRACTING AND ASSIGNMENT Supplier shall not contract with any subcontractor and/or vendor without the prior written consent of HCSL. Such consent shall not relieve the Supplier from any of his responsibilities and liabilities under the Purchase Order. In addition, Supplier shall ensure that the terms and conditions of any such contract shall comply with and correspond to the terms and conditions of the Purchase Order.</p>	
29.	<p>General: a. Prior to price bid opening, HCSL is at liberty to take the credit rating of</p>	

	<p>bidders at our cost on case-to-case basis, and to include the same during the evaluation of the tender.</p>	
	<p>b. Deviations, if any in the techno-commercial offer from that of the tender enquiry in any form should be clearly furnished in a separate document titled as “List of Deviations”, failing which it will be presumed that all the terms and conditions are acceptable.</p>	
	<p>c. The techno-commercial part alone will be opened initially on the due date of tender. The price part will be opened only after evaluation of the Techno commercial part. Date of opening of the price part will be intimated to those firms whose Techno- commercial bids would be acceptable after the evaluation.</p> <p>Suppliers are allowed to depute their authorized representative to be present at the time of opening of Price Bid of their tender only.</p>	
30.	<p><u>Purchase Order</u> :- a. In the event supplier's offer leads to an agreement to effect supplies, a formal purchase order shall be issued by HCSL on the basis of agreed terms and conditions of tender.</p>	
	<p>b. Upon placement of order (by post or mail) the supplier shall submit the acknowledgement (ie: signed and stamped original/ scanned soft copy by mail) as a token of acceptance of order within 7 days. In case HCSL doesn't receive the above, it will be deemed as accepted.</p>	
31.	<p><u>INSPECTION:</u> - a) HCSL reserve the right to inspect the goods after receipt at HCSL store / prior to dispatch (by HCSL or HCSL authorized agency at yard cost). Short supply / Mismatch / Replacement of Defective items / those not meeting agreed / contractual specification/ Items failing during commissioning shall be sent on courier freight prepaid/delivered at HCSL store.</p>	
	<p>b) Replacements during guarantee period to be sent on Duty and all taxes paid basis to location as required by yard/vessel owner with all expenses to supplier account.</p>	
	<p>c) Defective items, if any, after receipt shall be sent back on cost, carriage, handling and insurance prepaid basis including re-export (wherever desired by supplier) to be arranged by supplier. Defective items shall be returned after receipt of replacement item. Supplier, shall replace all/ part of items as applicable, in case of rejection, within 1 week of reporting the defect, without any additional cost to HCSL. In case the defective materials are not taken back within the said period, HCSL reserves the right to dispose the same without further intimation.</p>	

	d) The supplier shall compensate HCSL for loss on account of shortage in quantity and number of pieces received than that indicated in the bill of landing provided the HCSL's claim is rejected by the insurance due to any fault of supplier. Such claims, if any, shall be supported by recognized surveyors report. The supplier shall also compensate for losses, if any sustained by the HCSL due to defective packing and/or marking of the goods not in accordance with the terms of contract. The time limits for filing claims under clauses above shall be generally 180 days from the date of complete discharge of goods.	
32.	Preservation & Packing: a. The preservation and packaging of the items to ensure that there is no damage and deterioration during transit and the period when the item is in storage in store house. b. Requirement of special provisions for storage and transportation to be specifically indicated.	
33.	HCSL reserves the right to alter, modify the scope of supply at its discretion and in consistent with the policy of the Government of India and statutory bodies under them as applicable to the contract from time to time.	
34.	HCSL reserves the right to commercially reject the offer if compliance is not issued to General terms and conditions without any further clarification / notice / communication in this regard from M/s. Hooghly Cochin Shipyard Ltd., even though the offer is technically acceptable.	
35.	MSEs, Startups and Make in India: Local Suppliers (Make in India), MSE firms and Start-ups will be eligible for various Relaxation in pre-qualification criteria and other Benefits as per orders promulgated by Government of India. Bidders are advised to refer the details of various Benefits and Relaxations in pre-qualification criteria as published at CSL website (www.cochinshipyard.com) under the Tenders tab.	

Specify Yes / No

Tender conditions for Restriction of bidders sharing land border with India vide Office memorandum dt 23.7.2020 Order - Public Procurement no 1 dt 23.7.2020, Order no 2 dt 23.7.2020 and order no 3 dt 24.7.2020	
A	Requirement of registration
1	Any bidder from a country which shares a land border with India will be eligible to bid in this tender only if the bidder is registered with competent authority as per C below. In works contracts, including turkey contracts, contractors shall not be allowed to sub contract works to any contractor from a country which shares a land border with India unless such contractor is registered with Competent authority. Relevant certificate to be submitted by bidder from a country which shares land border with India except for bidders to which Govt of India has extended lines of Credit or in which Govt of India has development projects, along with the offer as proof of registration with competent authority, failing which the offer will not be considered. A certificate is to be submitted by the bidder for compliance with the order referred above along with tender documents for consideration of offer (Wordings are as per Clause below). If such certificate given by a bidder whose bid is accepted is found to be false, this would be a ground for immediate termination and further legal action in accordance with law.
2	Wordings of certificate to be submitted along with tender documents
	I have read the clause regarding restrictions on procurement from a bidder of a country which shares a land border with India. I hereby certify that this bidder is not from such a country or, if from such a country, has been registered with the competent authority. I hereby certify that this bidder fulfils all requirements in this regard and is eligible to be considered. (Evidence of valid registration by the competent authority shall be attached wherever applicable).
2	Wordings of certificate to be submitted along with tender documents for Works involving possibility of sub-contracting.
	I have read the clause regarding restrictions on procurement from a bidder of a country which shares a land border with India and on sub-contracting to contractors from such countries. I certify that this bidder is not from such a country or if from such a country has been registered with the competent authority and will not subcontract any work to a contractor from such countries unless such contractor is registered with the competent authority. I hereby certify that this bidder fulfils all requirements in this regard and is eligible to be considered (Evidence of valid registration by the competent authority shall be attached wherever applicable)
B	Validity of registration
1	Registration should be valid at the time of submission of bids and at the time of acceptance of bids. In respect of supply otherwise than by tender, registration should be valid at the time of placement of order. If the bidder is validly registered at the time of acceptance /order placement, registration shall not be a relevant consideration during contract execution.
C	Competent authority and Procedure for registration

1	The competent authority for the purpose of registration under the order shall be Registration committee constituted by the Department of Promotion of Industry and Internal Trade (DPIIT). Details of the committee and procedure for registration and restrictions shall be as per Ann I of the Order - Public Procurement no 1 dt 23.7.2020 issued by Ministry of Finance, department of Expenditure.
D	Definition of Bidder and Bidder from a country sharing land border with India
1	Bidder is defined as any person or firm or company including any, member of a consortium or joint venture, every artificial, juridical person not falling in any of the descriptions of bidders stated hereinbefore, including any agency, branch or office controlled by such person, participating in a procurement process.
2	<p>"Bidder from a country which shares a land border with India" for the purpose of this Order means:-</p> <ul style="list-style-type: none"> a) An entity incorporated, established or registered in such a country; or b) A subsidiary of an entity incorporated, established or registered in such a country; or c) An entity substantially controlled through entities incorporated, established or registered in such a country; or d) An entity whose beneficial owner is situated in such a country; or e) An Indian (or other) agent of such an entity; or f) A natural person who is a citizen of such a country; or g) A constitution or joint venture where any member of the consortium or joint venture falls under any of the above.
3	<p>Type of business entity</p> <p>(Private Limited Company/ Public Limited Company/ Sole Proprietorship/ One Person Company/ Partnership/ Limited Liability Partnership/ Joint Venture/ Trust/ NGO)</p> <p>In case of incorporated entity - to attach certificate of incorporation</p>
	<p>Beneficial Owners</p> <p>- as defined in the Department of Expenditure Order (Public Procurement No.1) issued vide No. F.No.6/18/2019-PPD dated 23rd July, 2020.</p> <p>Details of all beneficial owners having entitlement of more than 01% of shares or capital or profit to be given, in the format as given in Annexure-I duly certified by practicing Chartered Account in India.</p>

COMPLIANCE STATEMENT- SPECIAL INSTRUCTIONS FOR TENDERERS AND TECHNICAL SPECIFICATION		PAGE 1 OF 1
Tender Name: Supply of materials for Sealing Arrangement of Cargo Hatch Cover for JAK 2200T MPV Vessels at Hooghly Cochin Shipyard Limited, Nazirgunge Unit, Howrah.		
TENDER NO: HCSL/OPS/SB/TEN/037/2024-25 DATE: 22.07.2024		
We hereby confirm and truly declare that our Offer / Bid No.datedis in full compliance with the documents issued against the Tender No. -----dated -----, except for the deviations listed below:		
<u>LIST OF DEVIATIONS (HCSL reserves the right to reject offers with deviations)</u>		
Sl. No.	Tender Reference & Description	Reasons for Deviation/Remarks
Name of tenderer:		
Date:	Name & Designation	Seal & Signature
Seal)		(Company

NEFT MANDATE FORM

(ON THE LETTER HEAD OF THE COMPANY)

Electronic Payment Mandate Form

(Mandate for receiving payments through RTGS/NEFT Hooghly Cochin Shipyard Ltd)

- 1) Vendor Name
- 2) Vendor Address with Phone No
- 3) Vendor Code
- 4) Permanent Account No. (PAN)
- 5) Particulars of Bank Account
 - a. Name of the Bank
 -
 - b. Name of the Branch
 -
 - c. Branch Code
 - d. NEFT Code of the Bank
 - e. City Name
 - f. Branch Location
 - g. Branch Telephone No.
 - h. Bank IFSC Code
 - i. 9-Digit MICR Code

(Where MICR is starting with "0". Please take the correct code from your bank for proper identification of city, bank, branch)

- i. Type of the Account (S.B Current or Cash Credit) with code

 (010/011/013)
- j. Account Number (as appearing on the cheque book)

6) Email Address of Vendor

7) Date of Effect of RTGS/NEFT in your Bank

(Please enclose a cancelled un-signed cheque leaf to enable us to verify the details mentioned above)

We hereby declare that the particulars given above are correct and complete. If the transaction is delayed or lost because of incomplete or incorrect information, we would not hold the company responsible.

(.....)

Signature of Employee

Bank Certificate
We certify that _____ has an Account No. _____

with us and we confirm that the details given above are correct as per our records.

Date:

Place:

(.....)
Authorized official of Bank

BANK GUARANTEE IN LIEU OF SECURITY DEPOSIT

To

HOOGHLY COCHIN SHIPYARD LTD

(Govt. of India Enterprise,)

Satyen Bose Road,

Danesh SK Lane (PO),

Nazirgunge, Howrah,

West Bengal - 711109.

WHEREAS(Name & Address of Supplier)
(hereinafter called" **the Supplier**") has undertaken, in pursuance of
Contract.....No.....Dated.....to
execute(Name of Contract and brief description of works)
(hereinafter called" **the Contract**").

AND WHEREAS it has been stipulated by **HOOGHLY COCHIN SHIPYARD LTD**
(The Buyer – hereinafter called "**HCSL**") in the said contract that the Supplier shall furnish
HCSL with a Bank Guarantee for the sum specified therein as security for compliance
with the Supplier’s obligations in accordance with the Contract.

AND WHEREAS we have agreed to give the Supplier such a Bank Guarantee.

NOWTHEREFORE we..... (Name of the Bank) having its Head Office
at..... (Address of Head Office)and acting through its branch office
at.....(Address of the executing branch)(hereinafter called" the Bank")
hereby affirm that we are the Guarantor and responsible to **HCSL**, on behalf of the Supplier
upto a total of.....(amount of Guarantee) in words).

We, the bank, hereby irrevocably undertake to pay you any amount not exceeding in total
the Guarantee Amount upon receipt by us of your demand in writing accompanied by the
following documents:

1. Your signed statement certifying that the Supplier is in breach of his
obligation(s)under the Contract and the respect in which the Supplier is in breach.
2. Your signed statement certifying that the Supplier has been given a prior written
notice by email from you to make good the aforesaid breach and that the Supplier
still failed to fulfill the Contract within 30 days of such notice. A copy of such
notice given by email to the Supplier shall be attached to the demand for payment.

Any demand for payment should contain your authorized signatures which must be
authorized by your bankers or by a notary public.

We, the Bank, further agree that no change or addition to or other modification of the terms
of the Contract or of the Works to be performed there under or of any of the Contract
documents which may be made between **HCSL** and the Supplier shall in any way release
us from any liability under this guarantee, and we hereby waive notice of any such change,-

addition or modification. We, the Bank, further agree that any change in the constitution of the said contractor or the said bank shall not discharge our liability hereunder.

Notwithstanding anything contained herein:

1. Our liability under this Bank Guarantee shall not exceed(only).
2. This Bank Guarantee shall be valid upto (date)and
3. We are liable to pay the guaranteed amount or any part thereof under this bank guarantee only and only if **HCSL** serve upon us a written claim or demand on or before..... (validity date).

Any demand for payment under this guarantee must be received by us at this office during working hours on or before the validity date. Should we receive no claim from you by the validity date, our liability to you will cease and the guarantee will definitely become null and void whether returned to us or not.

Yours truly,

Signature and seal of the

Guarantor.....

Name of

Bank.....

...

Address.....

Date.....

An amount shall be inserted by the Guarantor, representing the percentage of the Contract Price specified in the Contract and denominated in respective Dollars / Indian Rupees/Other Currency.

Tender condition- Preference to Make in India	
A	Purchase preference in accordance with public procurement (Preference to Make in India Order – 2017) Order from Department of Promotion of Industry and Internal Trade P–45021/2/2017/–B. E–II dt,4.6.2020 and as amended from time to time shall be applicable as per below
1	In the procurement of all goods/services/works in respect of which there is sufficient local capacity /local competition, only Class I Local suppliers shall be eligible to bid irrespective of purchase value
2	In the procurement of all goods/services /works which are not covered as above and with estimated value of purchase less than Rs 200.0 Crores, only Class I local Suppliers along with Class II local suppliers shall be eligible to bid.
Purchase preferences for Class I local suppliers	
B	In the procurement of goods/works covered under 2 above and which are divisible in nature, Class I local supplier shall be eligible for Purchase preference over Class II / Non local supplier as per following
1	If L1 bid is not a Class I local supplier, 50% of the order quantity shall be awarded to L1. Thereafter the lowest bidder among Class I local supplier will be invited to match the L1 price for the remaining 50% quantity subject to Class I local supplier quoted price falling within 20% margin. Contract for that quantity shall be awarded to such Class I local supplier subject to matching L1 price. In case such lowest eligible Class I local supplier fails to match L1 price or accept less than offered quantity, next higher Class I local supplier within 20% margin shall be invited to match the L1 price for the remaining qty and so on. If some quantity is left uncovered on Class I local supplier, such balance quantity shall be ordered on L1 bidder.
2	For procurements that are not divisible in nature and in procurement of services evaluated on price alone, Class I local supplier shall get purchase preference over Class II/Non local supplier as per below
3	If L1 is not a Class I local supplier, lowest bidder among Class I local supplier will be invited to match L1 price subject to Class I local supplier quoted price falling within 20% of L1 price and contract will be awarded to such Class I local supplier, subject to matching L1 price. In case such lowest eligible Class I local supplier fails to match L1 price, procedure same as para 3 above will be opted. In case none of Class I local suppliers within 20% margin matches L1 price, contract shall be awarded to L1 bidder. The purchase preference as above will be only for Class I local supplier and Class II local supplier will not be eligible for any Purchase preference
C	Local content requirement to categories a supplier as Class I/Class II/Non local supplier shall be as per below. Definition of local content shall be as per order dt 4.6.2020 i.e. amount of value added in India which shall be the total value of the item procured (excluding net domestic indirect taxes) minus the value of import content in the item (including all customs duties) as a proportion of total value in percentage.
1	Class I–Local content equal to or greater than 50%
2	Class II–Local content greater than 20%, less than 50%

3	Non-local–Local content less than 20%
D	Declaration of local content
1	Class I local supplier /Class II local supplier at the time of tender shall indicate % of local content and provide self-certification that offered item shall meet the local content requirement for Class I/Class II as applicable including details of locations at which local value addition is made.
2	In case of procurement for a value in excess of Rs 10.0 Crores Class I/Class II local supplier is to provide a certificate from statutory auditor/cost auditor (for companies) /practicing cost accountant/ Chartered accountant (suppliers other than companies) indicating % of local content
3	Verification of the Certificates issued by the bidder shall be carried out by HCSL on random basis. False declarations will attract actions as stipulated in the order referred, including other actions as permissible by law.
4	Exemption is applicable from provisions of order for purchases with estimated values less than Rs 5.0 lakhs
5	Notwithstanding above, exemptions for meeting local content as per relevant Clause of order dt 4.6.2020 and as amended from time to time shall apply.

VENDOR DETAILS (to be submitted along with BID)

1	Name of Bidder/Firm	
2	Registered office Address of Company/firm in Kolkata/Howrah: Local office address at Kolkata/Howrah (if held):	
3	Telephone No./Fax No./Mobile No:	
4	E-mail address:	
5	Names of the contact person & Designation:	1) 2) 3)
6	Type of Entity-Proprietorship/Partnership firm/company/NSIC/MSME Category etc. (Please attach registration certificate of Firm/Partnership agreement/proprietorship documents)	
7	Cost of Tender Details (DD No. Name of Bank)	NIL
8	EMD Details (DD No. Name of Bank)	NIL
9	PAN Card Number (Self-attested copy of PAN card has to be Submitted)	
	GST Registration No. (Self-attested copy has to be Submitted)	
10	Whether the agency has been blacklisted/de barred or given tender holiday or contract terminated before expiry of the contract period by any govt. autonomous bodies/organizations where bidder has provided services earlier due to deficiencies in service or misconduct etc.	Yes/No (Please tick as applicable) If yes, please furnish details on a separate sheet

- **Certified that the above information is true to the best of our belief and information.**

Place:

Date:

Signature of Supplier/Authorized signature of firm/agency:

Name of Supplier or authorized signatory of firm/agency:

Designation:

Self-Declaration to be given by the bidder in Letter head

Bid's Reference No. & Date:

Bidder's Name & Address:

Person to be contacted:

Designation:

Telephone No.:

Fax No.:

Email:

1. We do hereby declare that we have not been debarred/black listed by HCSL or by any of the Public Sector Undertaking or Government department etc.

2. If HCSL finds that, we have been blacklisted/ debarred by any of the Public Sector Undertaking or Government department, and then HCSL can reject the offer or terminate the contract at any point of time. In such case, we are aware that, EMD, security deposit, performance guarantee etc. will be forfeited by HCSL. Further we are confirming herewith that, any loss that has happened to HCSL due to this will be compensated by us.

For and on behalf of the firm

(Firms Name & Address)

(Signature of Authorized Signatory)

Name:

Designation

Phone No.:

Seal:

Date:

Place.....

(Sample Format)

Details of legal cases pending against the firm for the last five years

L. NO.	ORGANISATION AGAINST WHOM THE LITIGATION IS INVOLVED	BRIEF DETAILS OF DISPUTE	AMOUNTS INVOLVED (Rs.)	PRESENT STATUS	Remarks

SIGNATURE OF BIDDER