

कोचीन शिपयार्ड लिमिटेड / COCHIN SHIPYARD LIMITED  
कोची / COCHIN - 682 015

पोत निर्माण प्रभाग / SHIP BUILDING DIVISION

आउटसोर्सिंग विभाग  
OUTSOURCING DEPARTMENT



निविदा दस्तावेज़ / TENDER DOCUMENT

**TENDER NO. SB-OSD/CSOV/921/2025 Dtd 04-02-2025**

**IN-SITU MACHINING & DRILLING OF AZIMUTH THRUSTER  
FOUNDATIONS IN COMMISIONING SERVICE OPERATIONAL  
VESSEL (CSOV) BY.151**



**FEBRUARY - 2025**

**विषय - सूची / CONTENTS**

क्र.सं. SL.No.	विवरण DESCRIPTION	संदर्भ REFERENCE
1	निविदा सूचना TENDER NOTICE	
2	जांच के नियम और शर्तें TERMS & CONDITIONS OF ENQUIRY	अनुलग्नक ANNEXURE I
3	सामान्य शर्तें GENERAL CONDITIONS	अनुलग्नक ANNEXURE II
4	कार्यों का विषय क्षेत्र/ तकनीकी विनिर्देश SCOPE OF WORKS / TECHNICAL SPECIFICATION	अनुलग्नक ANNEXURE III
5	वाणिज्यिक जांच सूची COMMERCIAL CHECK LIST	अनुलग्नक ANNEXURE IV
6	मूल्य बोली प्रारूप PRICE BID FORMAT	अनुलग्नक ANNEXURE V
7	बयान DECLARATION	अनुलग्नक ANNEXURE VI
8	अनुपालन के लिए मैट्रिक्स COMPLIANCE MATRIX	अनुबंध APPENDIX A
9	वित्तीय क्षमता के लिए प्रारूप FORMAT FOR FINANCIAL CAPABILITY	अनुबंध APPENDIX B
10	प्रदर्शनी मूल्यांकन प्रपत्र PERFORMANCE EVALUATION FORM	अनुबंध APPENDIX C
11	चित्र DRAWINGS	अनुबंध APPENDIX D

**TENDER ENQUIRY NOTICE – IN-SITU MACHINING & DRILLING OF AZIMUTH THRUSTER FOUNDATIONS IN COMMISIONING SERVICE OPERATIONAL VESSEL (CSOV)****निविदा सूचना / TENDER NOTICE**  
**कोचीन शिपयार्ड लिमिटेड / COCHIN SHIPYARD LIMITED****पोत निर्माण प्रभाग / SHIP BUILDING DIVISION**  
**आउटसोर्सिंग विभाग/ OUTSOURCING DEPARTMENT**

SB-OSD/CSOV/921/2025

04<sup>th</sup> FEBRUARY - 2025**निविदा सूचना / TENDER NOTICE****संक्षिप्त विवरण / BRIEF DETAILS:**

निविदा जांच संख्या और तारीख Tender enquiry No. and date	SB-OSD/CSOV/921/2025 Dtd 04-02-2025
कार्य का नाम Name of work	IN-SITU MACHINING & DRILLING OF AZIMUTH THRUSTER FOUNDATIONS IN COMMISIONING SERVICE OPERATIONAL VESSEL (CSOV)
निविदाएं प्राप्त करने की अंतिम तिथि और समय Last date & time of receipt of Tenders (भाग/Part I – तकनीकी-वाणिज्यिक बोली और भाग - II मूल्य बोली/ Techno-Commercial Bid & Part II-Price Bid)	18 <sup>th</sup> February - 2025 at 15.00 Hrs IST
पूर्व बोली बैठक की तारीख Date of Pre bid meeting	12 <sup>th</sup> February - 2025 at 11.00 Hrs IST
भाग I (तकनीकी-वाणिज्यिक) बोली खोलने की तिथि और समय Date & time of opening of Part I (Techno – Commercial) Bid	18 <sup>th</sup> February - 2025 15.30 Hrs IST
संपर्क व्यक्ति Contact Person	<b><u>For Commercial queries:</u></b> Mr. Adarsh S, AM (Outsourcing), Mob No: 8714630926. <b><u>For Technical queries:</u></b> Harikrishnan K M, Manager (MOF) Mob. No: 8138917185



**TENDER ENQUIRY NOTICE – IN-SITU MACHINING & DRILLING OF AZIMUTH THRUSTER FOUNDATIONS IN COMMISSIONING SERVICE OPERATIONAL VESSEL (CSOV)**

**नोट:** इस निविदा के खिलाफ उद्धृत करने से पहले, संभावित बोलीदाता से अनुरोध है कि वे निविदा जांच दस्तावेज़ (और अनुलग्नक, यदि कोई हो) को पूरी तरह से और सावधानी से पढ़ लें। निविदा के नियमों और शर्तों में विचलन अत्यधिक हतोत्साहित किया जाता है। इसलिए, निर्धारित किसी भी नियम और शर्तों, योग्यता मानदंड, ईएमडी जमा करने से छूट के लिए पात्रता, दस्तावेज़ीकरण/प्रक्रियात्मक आवश्यकताओं आदि के संबंध में स्पष्टीकरण, यदि कोई हो, के संबंध में उत्पन्न होने वाले किसी भी संदेह को संभावित बोलीदाता द्वारा बोली जमा करने से पहले निरपवाद रूप से उपरोक्त सूचित व्यक्तियों के माध्यम से अनिवार्य रूप से स्पष्ट किया जाएगा।

**Note:** Before quoting against this Tender, the prospective bidder is requested to go through the Tender Enquiry document (& Annexes, if any) thoroughly & carefully. Deviations to the Terms & Conditions of the Tender are highly discouraged. Therefore, any doubts arising in respect of any of the Terms & Conditions stipulated, Qualification Criteria, Eligibility for exemption from submission of EMD, clarification if any w.r.t. Documentation / Procedural requirements, etc. shall get clarified by the prospective bidder through above noted contact persons invariably before the submission of the Bid.

1. कोचीन शिपयार्ड लिमिटेड, एक प्रमुख पोत निर्माण और पोत मरम्मत उद्योग और वैश्विक पोत निर्माण के मोर्चे पर विख्यात, इच्छुक, प्रतिष्ठित, संसाधन संपन्न और वित्तीय रूप से सक्षम कंपनियों/ठेकेदारों को एकल चरण दो भाग बोलियों को प्रस्तुत करने हेतु आमंत्रित करता है।

**Cochin shipyard Limited, a leading Ship Building & ship repair industry and also well known player on the global ship building front, invites interested, reputed, resourceful and financially solvent firms/contractors to submit single stage two part bids for this Limited tender.**

2. निर्धारित प्रपत्र में मुहरबंद प्रतिस्पर्धी निविदाएं निविदा जांच के अनुलग्नक में उल्लिखित नियम और शर्तों के अनुसार होनी चाहिए।

The Sealed competitive tenders in the prescribed form should be as per the terms and conditions as mentioned in the annexure to tender enquiry.

3. निविदा के कार्यक्षेत्र के विस्तार पर चर्चा करने के लिए निविदा पूर्व बैठक दिनांक **12.02.2025** को सीएसएल के योजना सम्मेलन कक्ष में पूर्वाह्न **11.00** बजे से आयोजित की जाएगी। पूर्व निविदा बैठक में भाग लेने के इच्छुक ठेकेदारों को अपने पूर्व निविदा प्रश्नों (यदि कोई हो) को दिनांक **12.02.2025** तक सकारात्मक रूप से सूचित और अग्रेषित करना चाहिए।

**The pre-bid meeting will be held on 12.02.2025 at Ship Building Conference Hall (Prerana) - of CSL from 11.00 AM to discuss the detail scope of work of the tender. The Contractors interested to participate in Pre-bid meeting should inform and forward their Pre-bid queries (if any) by 12.02.2025 positively.**

**TENDER ENQUIRY NOTICE – IN-SITU MACHINING & DRILLING OF AZIMUTH THRUSTER FOUNDATIONS IN COMMISSIONING SERVICE OPERATIONAL VESSEL (CSOV)**

4. निविदाएं दो बोली प्रणाली में प्रस्तुत की जानी हैं; भाग I: तकनीकी वाणिज्यिक बोली और भाग II: सॉफ्ट कॉपी के रूप में मूल्य बोली और निर्धारित तिथि और समय पर या उससे पहले अधोहस्ताक्षरी के पास पहुंच जानी चाहिए:

The tenders are to be submitted in two bid system; **Part I : Techno Commercial Bid** and **Part II : Price Bid** as Soft copy and should reach the undersigned on or before the date and time as stipulated:

5. **MODE OF SUBMISSION OF BIDS**

- a. निविदा केवल ई-मेल के माध्यम से सॉफ्ट कॉपी में प्रस्तुत की जानी चाहिए। सीएसएल किसी अन्य प्रकार की निविदा स्वीकार नहीं करेगा।

**Tender should be submitted in soft copy via E-mail only. CSL will not accept any other mode of tender.**

- b. ई-मेल के विषय में स्पष्ट रूप से निविदा पृष्ठताछ संख्या और जमा करने की देय तिथि का उल्लेख होना चाहिए। मूल्य बोलियों को पासवर्ड से सुरक्षित किया जाना चाहिए और जब तक मांगा नहीं जाता तब तक पासवर्ड अग्रेषित नहीं किया जाना चाहिए।

The subject of the E mail should clearly state the tender enquiry number and due date of submission. Price Bid is to be password protected and password is not to be forwarded unless asked for.

- c. निविदा दस्तावेज़ पीडीएफ प्रारूप में प्रस्तुत किया जाना चाहिए और पीडीएफ प्रारूप से सीधे खोला जा सकता है। उपरोक्त का अनुपालन न करने वाले प्रस्तावों को बिना किसी सूचना के सरसरी तौर पर खारिज कर दिया जाएगा।

Tender Documents should be submitted in PDF Format and Directly openable from the PDF format. Offers not complying with the above shall be summarily rejected without further intimation.

- d. निविदाएं, तकनीकी - वाणिज्यिक बोली (भाग-I) और मूल्य बोली (भाग-II) अलग से ई-मेल के माध्यम से **“SB-OSD/CSOV/921/2025”** विषय के साथ प्रस्तुत की जाएगी।

Tenders, Techno- commercial bid (Part-I) and Price bid( Part -II) shall be submitted separately via email , with subject as **“ SB-OSD/CSOV/921/2025”** to:

- (i) [ashtal.antony@cochinshipyard.in](mailto:ashtal.antony@cochinshipyard.in)

- (ii) [adarsh.s@cochinshipyard.in](mailto:adarsh.s@cochinshipyard.in)

प्रतिलिपि / Copy to:

- (iii) [madhu.pk@cochinshipyard.in](mailto:madhu.pk@cochinshipyard.in)

- (iv) [philip.thomas@cochinshipyard.in](mailto:philip.thomas@cochinshipyard.in)

6. बोलियां दिनांक **18 फ़रवरी - 2025** को अपराह्न **15.00** बजे या उससे पहले कोचीन शिपयार्ड लिमिटेड में प्राप्त की जाएंगी और भाग I तकनीकी - वाणिज्यिक बोली उसी दिन अपराह्न **15.30** बजे खोली जाएगी।

**The Bids shall be received at Cochin Shipyard Ltd on or before 15.00 Hrs on 18<sup>th</sup> February - 2025 and Part I Techno-Commercial Bid will be opened at 15.30 Hrs on the same day.**

**TENDER ENQUIRY NOTICE – IN-SITU MACHINING & DRILLING OF AZIMUTH THRUSTER FOUNDATIONS IN COMMISSIONING SERVICE OPERATIONAL VESSEL (CSOV)**

7. देर से आनेवाली निविदाएं/शर्तों वाली निविदाएं सरसरी तौर पर खारिज कर दी जाएंगी।  
Late tenders / tenders with conditions will be summarily rejected.
8. सीएसएल ई-मेल द्वारा भेजी गई निविदाओं के विलंब, खो जाने या प्राप्त न होने की कोई ज़िम्मेदारी नहीं लेगा।  
CSL takes no responsibility for delay, loss or non-receipt of tenders sent by e-mail.
9. मूल्य बोली खोलने के लिए केवल तकनीकी रूप से योग्य बोलियों पर विचार किया जाएगा। तकनीकी पहलुओं और वाणिज्यिक शर्तों दोनों के लिए बोलियों का मूल्यांकन करने के बाद, तकनीकी-व्यावसायिक रूप से योग्य बोलीदाताओं को भाग-II  
Only technically qualified bids will be considered for price bid opening. After evaluating the bids for both technical aspects and commercial terms, the techno-commercially qualified bidders will be intimated regarding the date and time of opening of Part II - Price Bid.
10. केवल तकनीकी - वाणिज्यिक बोली खोलने को अनुबंध देने के लिए प्रस्ताव की स्वीकृति के रूप में नहीं माना जा सकता है।  
Merely opening of Techno-Commercial Bid cannot be construed as acceptance of offer for awarding of contract.
11. भाग I (तकनीकी-वाणिज्यिक) बोली के साथ निम्नलिखित प्रस्तुत किया जाएगा:

**The following shall be submitted along with Part I (Techno-commercial) Bid:-**

- i. अनुलग्नक I, II, III, IV, V और परिशिष्ट – A,B,C & D में रखे गए पूछताछ के नियम और शर्तें, समान्य शर्तें, तकनीकी विनिर्देश और आरेखण सहित सभी पृष्ठों पर विधिवत हस्ताक्षरित मूल निविदा दस्तावेज़।  
**Original tender document duly signed on all pages - including Terms & conditions of enquiry, general conditions, technical specification and drawings placed at Annexure I, II, III, IV, V & Appendix- A,B,C & D**
- ii. अनुलग्नक IV में तकनीकी वाणिज्यिक जांच सूची पूरी तरह से भरी हुई है और विधिवत हस्ताक्षरित है। विधिवत भरी हुई तकनीकी वाणिज्यिक जांच सूची प्रस्तुत न करने पर बोलियों को अस्वीकार कर दिया जाएगा।  
**The techno commercial Check List at Annexure IV filled up completely and duly signed. The non-submission of duly filled techno commercial checklist will lead to the rejection of the bids.**
- iii. गैर-मूल्य बोली प्रारूप की प्रतिलिपि (कीमत/अंकों के बिना मूल्य बोली)।  
**Copy of un-priced bid format (price bid WITHOUT prices/numerals)**
- iv. निविदा पूछताछ नियम और शर्तों से विचलन/बहिष्करण की सूची (यदि कोई हो)।  
List of deviations/exclusions from the tender enquiry terms and conditions (if any).

**TENDER ENQUIRY NOTICE – IN-SITU MACHINING & DRILLING OF AZIMUTH THRUSTER FOUNDATIONS IN COMMISSIONING SERVICE OPERATIONAL VESSEL (CSOV)**

**12. एमएसएमई - विशेषाधिकार / MSME- PRIVILEGES**

सीएसएल वेबसाइट ([www.cochinshipyard.in](http://www.cochinshipyard.in)) के अनुसार एमएसएमई, स्टार्ट-अप आदि से संबंधित भारत सरकार की सार्वजनिक खरीद नीति पहल इस निविदा के लिए लागू होगी।

Public procurement policy initiatives of Govt. of India, pertaining to MSME's, Start-up etc. as per CSL website ([www.cochinshipyard.in](http://www.cochinshipyard.in)) shall be applicable for this tender.

13. कोचीन शिपयार्ड लिमिटेड (सीएसएल) ने ट्रेड्स पोर्टल अर्थात आरएक्सआईएल, एम1 एक्सचेंज और इनवॉयस मार्ट में पंजीकरण कराया है। वे विक्रेता जिन्होंने ट्रेड्स पोर्टल में पंजीकरण कराया है, वे ट्रेड्स पोर्टल के ज़रिए भुगतान को संसाधित करने के लिए संबंधित निष्पादन अधिकारी को सूचना के तहत संबंधित पोर्टल में चालान अपलोड कर सकते हैं। आपूर्तिकर्ताओं से अनुरोध है कि ट्रेड्स पोर्टल में चालान अपलोड करने से पहले, जहां भी लागू हो, गुणवत्ता निरीक्षण स्थिति के संबंध में संबंधित निष्पादन अधिकारी से जांच करें।

14. Cochin Shipyard Limited (CSL) has registered in the TReDS Portal viz., RXIL, M1xchange and Invoice Mart. Those vendors who have registered in the TReDS portal may upload the invoice in the respective portal under an intimation to concerned executing officer for processing the payment through TReDS portal. Suppliers are requested to check with the concerned executing officer regarding the Quality inspection status, where ever applicable, before uploading the invoices in TReDS portal.

15. सीएसएल के पास पूरा ऑर्डर देने या ऑर्डर की मात्रा का कुछ हिस्सा देने या काम को दो या दो से अधिक फर्मों/उपठेकेदारों में विभाजित करने या किसी भी निविदा को स्वीकार या अस्वीकार करने, या निविदा खोलने की तारीख बढ़ाने, और या कुल निविदा प्रक्रिया को रद्द करने और सभी को अस्वीकार करने का अधिकार सुरक्षित है। अनुबंध प्रदान करने से पहले किसी भी समय निविदाएं। सीएसएल प्रभावित फर्म(फर्मों) के प्रति कोई दायित्व नहीं निभाएगा, सीएसएल की कार्रवाई के आधार के बारे में प्रभावित फर्म(फर्मों) को सूचित करने का कोई दायित्व नहीं होगा। बोलीदाताओं से अनुरोध है कि वे नोट करें और तदनुसार बोली लगाएं।

CSL reserves the right to place order whole or part of order quantity or split the work on two or more firms/subcontractors or to accept or reject any tender, or extend the tender opening date, and or to cancel the total tender process and reject all tenders at any time of the contract. CSL will not incur any liability to the affected firm(s), any obligation to inform the affected firm(s) of the grounds for CSL's action. Bidders are requested to note and quote accordingly.

16. मुख्य महाप्रबंधक, पोत निर्माण प्रभाग, कोचीन शिपयार्ड लिमिटेड, निविदा या उसके हिस्से को स्वीकार करने हेतु अधिकृत व्यक्ति है, जो न्यूनतम निविदा को स्वीकार करने हेतु स्वयं को बाध्य नहीं करता है और बिना कोई कारण बताए प्राप्त किसी या सभी निविदाओं को अस्वीकार करने का अधिकार सुरक्षित रखता है।



**TENDER ENQUIRY NOTICE – IN-SITU MACHINING & DRILLING OF AZIMUTH THRUSTER FOUNDATIONS IN COMMISSIONING SERVICE OPERATIONAL VESSEL (CSOV)**

General Manager, Ship Building Division, Cochin Shipyard Limited, is the authorized person to accept the tender or part thereof, who does not bind himself to accept the lowest tender and reserves the authority to reject any or all of the tenders received without assigning any reason.

कृते उप महाप्रबंधक / For Deputy General Manager  
आउटसोर्सिंग विभाग / Outsourcing Department





## ANNEXURE I

### जांच की नियम और शर्तें / TERMS & CONDITIONS OF ENQUIRY

#### IN-SITU MACHINING & DRILLING OF AZIMUTH THRUSTER FOUNDATIONS IN COMMISSIONING SERVICE OPERATIONAL VESSEL (CSOV)

##### 1. कार्य का विवरण / DESCRIPTION OF WORK

- 1.1. This tender enquiry pertains to the awarding contract for IN-SITU MACHINING & DRILLING OF AZIMUTH THRUSTER FOUNDATIONS IN COMMISSIONING SERVICE OPERATIONAL VESSEL (CSOV) as per the following documents:
  - 1.1.1. Cochin Shipyard Ltd - Terms and conditions (Annexure I)
  - 1.1.2. Cochin Shipyard Ltd - General conditions (Annexure II)
  - 1.1.3. Enquiry specification (Annexure III)
- 1.2. The scope of work involves the In-situ machining of the foundation for the Azimuth Thruster, as per the drawings, tolerances, specifications, work completion schedule, CSL - Terms and conditions in all respects.
- 1.3. Bidders are requested to study the scope of work before submitting their offer. Clarification, if any, required may be obtained from **Manager (MOF)** before quoting.

##### 2. चिक्रेताओं के लिए पात्रता मानदंड / QUALIFICATION CRITERIA FOR VENDORS

- 2.1. The firm should have a proven track record of completing similar types of projects.
- 2.2. The contractor should have the capability to work continuously, round the clock, to meet production schedules.
- 2.3. Relevant supporting documents shall be submitted by the contractors for validating the requirements as per (2.1) and (2.2).
- 2.4. Bidder shall not be under a declaration of ineligibility issued by Govt. of India/ State govt./Public Sector Undertakings etc. The bidder shall not have been debarred / black listed by CSL or by any of the Public Sector Undertaking or Government department etc.

**TENDER ENQUIRY NOTICE – IN-SITU MACHINING & DRILLING OF AZIMUTH THRUSTER FOUNDATIONS IN COMMISSIONING SERVICE OPERATIONAL VESSEL (CSOV)**

**3. FINANCIAL CAPABILITY**

- 3.1. The bidder shall have an average annual financial turnover of **Rs. 5 Lakh** during the last three years ending on 31st March 2024.
- 3.2. The Bidder shall enclose with its Proposal, certificate issued by Chartered Accountant with their seal and signature, stating its, turnover and profit during the past three years. Certificate shall be as per the format placed at Appendix – B.

**4. प्रस्ताव की वैधता / VALIDITY OF OFFER**

- 4.1. The offer shall be valid for acceptance for a period of 90 days from the date of opening of the Part-I Techno-Commercial Bid.

**5. काम की मात्रा / QUANTUM OF WORK**

- 5.1. The quantum of work proposed to be offloaded under this contract is Machining of 02 Azimuth Thruster Foundation and Drilling of Bolt Holes in the Azimuth Thruster Foundation (30 holes per foundation) as per attached machining drawings provided by CSL.

**6. अनुबंध प्रदान करने का तरीका / METHOD OF AWARDING CONTRACT**

- 6.1. Contract will be concluded with the bidders qualifying to techno-commercial conditions and emerging as L1 bidder.
- 6.2. Once work order is placed successful bidder should be able to start the works immediately.
- 6.3. CSL reserves the right to cancel the tender at any stage without assigning any reasons whatsoever based on CSL requirement. The decision of CSL regarding the same shall be final and conclusive.

**7. अनुबंध की वैधता / VALIDITY OF CONTRACT**

- 7.1. Once the contract is awarded, the price offered and mutually agreed shall remain firm (Contract concluded price as per Annex-V) till completion of work and no escalation in rate shall be allowed by CSL on whatsoever reason thereafter.
- 7.2. The contract shall be valid for one vessel. However, the contract may be further extended to other vessel (BY.152) with the same rate and conditions based on overall project timelines and awarded work performance of the firm.

8. **कार्य की प्रगति तथा समापन की समय - सारणी / WORK PROGRESS AND SCHEDULE OF COMPLETION**

- 8.1. The successful bidder must be able to complete mobilization of equipments and commence work within 7 days from the date of notification.
- 8.2. The contractor is required to work around the clock to meet the project deadlines.
- 8.3. The maximum time allocated for completing each foundation is as follows:
- 8.3.1. Machining activity should be completed within 03 days including machine setup.
- 8.3.2. Drilling activity should be completed within 02 days including machine setup.

9. **कार्य प्रक्रिया / WORK PROCEDURE**

- 9.1. The work procedure briefly described below, detailed for each category of works are mentioned in the Annexure III to the tender enquiry.
- 9.2. Necessary job instructions, drawings etc. for the work will be issued by CSL.
- 9.3. Contractor is to carry out the work as per the specifications / drawings supplied, and to the satisfaction of CSL.
- 9.4. Contractor should maintain the quality as per CSL Quality Standards, yard quality procedures.
- 9.5. Contractor shall submit the weekly /monthly progress reports to CSL.

10. **बोलियां जमा करने के लिए दिशानिर्देश / GUIDELINES FOR SUBMISSION OF BIDS**

9.1. **Technical Bid ( Part –I )**

- 9.1.1. **The following shall be submitted along with technical Bid, failing which the bid may be summarily rejected :-**
- 9.1.2. The technical bid as specified in the scope of work (Annexure III) duly signed shall be submitted along with the offer
- 9.1.2.1. Original tender document general Terms & conditions and technical specifications placed at Annexure I, II & III duly signed on all pages.
- 9.1.2.2. The commercial Check List at Annexure IV filled up completely and duly signed
- 9.1.2.3. Copy of un-priced bid format of each category of works at Annexure V.
- 9.1.2.4. All other documents relevant to this tender.
- 9.1.3. The non-submission of duly filled commercial checklist will lead to the rejection of the bids.

**TENDER ENQUIRY NOTICE – IN-SITU MACHINING & DRILLING OF AZIMUTH THRUSTER FOUNDATIONS IN COMMISIONING SERVICE OPERATIONAL VESSEL (CSOV)**

**9.2. Price Bid ( Part-II )**

- 9.2.1. The bid shall be comprehensive of the nature of **In-Situ Machining & Drilling Of Azimuth Thruster Foundations in Commisioning Service Operational Vessel (CSOV)** and shall be inclusive for all the applicable charges envisaged under the scope of the contractor as specified in the technical specification Annexure III and other terms & conditions of this tender.
- 9.2.2. Bidders shall quote total amount in figures and in words. Corrections and additions if any must be attested/ duly signed by the bidder. In the case of error in multiplication/addition in amount calculated, the unit rate quoted will be considered as correct and the amount will be calculated accordingly. Conditional rebates & discounts, incomplete/ ambiguous offer will be rejected.
- 9.2.3. The price bid shall be all inclusive of scope of contractor on unit rate basis and any rates on variable basis will not be accepted within the price bid and thereafter throughout the period of the contract. Any variable rates if deemed inevitable and applicable only in special cases/situations (not in the normal course of execution of contract) will only be considered for mutual agreement.
- 9.2.4. Price Bid Format: The price bids shall be prepared as per the format given in Annexure V to the enquiry. The bidder must quote all line items as per price bid format any failure in this regard will lead to the rejection of bid. L1 will be determined based on Sub total amount.
- 9.2.5. Rates of individual line items for the overall L1 is considered as L1 rate irrespective of lower rates in case of the line items of other bidders.
- 9.2.6. Currency: The price bids shall be prepared in Indian National Rupees for all bidders.
- 9.2.7. The bids which are not conforming above requirements shall be summarily rejected without any further notice.

**10. असामान्य रूप से कम उद्धृत दरें /ABNORMALLY LOW QUOTED RATES**

- 10.1. In case the price of L-1 Bidder is found to be unreasonably low and/ or bidder expresses desire to withdraw from the tender after opening of price bid, then tender will be cancelled and suitable penal action as per CSL procedure shall be taken against the firm.

**TENDER ENQUIRY NOTICE – IN-SITU MACHINING & DRILLING OF AZIMUTH THRUSTER FOUNDATIONS IN COMMISSIONING SERVICE OPERATIONAL VESSEL (CSOV)**

**11. कर / TAXES**

11.1. GST shall be applicable extra on the prescribed work. Bidders should indicate the applicable GST percentage and HSN code of the category in the offer. Bidders are also requested to furnish the following details in the invoice/Bill.

12.1.1. Applicable rate of GST/SAC Code

12.1.2. Firms GST Reg. NO

12.1.3. Service accounting code (SAC) as prescribed by statutory authorities.

12.1.4. GST Reg. No. of Cochin Shipyard Ltd (32AAACC6905B1ZD).

11.2. Any new tax/duty that may be made effective by the government for this work and paid by the contractor shall be reimbursed on production of documentary evidence.

**12. भुगतान की शर्तें / PAYMENT TERMS**

12.1. Payment will be made on 100% satisfactory completion of works on certification by the officer-in-charge.

12.2. All claims for payment for the work/additional work shall be submitted by the subcontractor within one month of completion of work.

12.3. An invoice upload facility by vendor is established through the Vendor Invoice Management (VIM) Portal is currently available for supply as well as service vendors including subcontractors so as to facilitate transparency and timely payment. The portal can be accessed at: <https://apps.cochinshipyard.in:446/vim/Home.jsp>

12.4. The same can also be accessed via Cochin Shipyard Website (<https://cochinshipyard.in>) as below;

12.5. Path: Cochin Shipyard Website --> Related Links --> Vendor Payment Info

12.6. All invoices above 10 Lakhs (including GST) are required to be digitally signed by the vendors and uploaded in VIM portal. The direct submission of invoices value above 10 Lakhs will not be accepted. Once the invoices are digitally signed and uploaded, there is no need to submit the hard copy for processing the payment.

12.7. Service Acknowledge Number (SAN) to be obtained from the Executing Officer at the time of certification of Work Completion Certificate (WCC) for the above process.

12.8. The invoice can be tracked using the generated Invoice Tracking Number till the payment.

12.9. Statutory levies such as I.T, Contribution towards PF, ESI etc., shall be deducted from the bill as applicable.

**TENDER ENQUIRY NOTICE – IN-SITU MACHINING & DRILLING OF AZIMUTH THRUSTER FOUNDATIONS IN COMMISSIONING SERVICE OPERATIONAL VESSEL (CSOV)**

12.10. Payment will be made by RTGS/NEFT to the account of contractor. The name of the bank, branch, A/C No., IFSC code & other particulars shall be furnished by the contractor in the proforma of CSL.

13. **बयाना राशि /EARNEST MONEY DEPOSIT (EMD)**

13.1. Bidders shall furnish Earnest Money Deposit (EMD) equivalent to **Rs. 1 Lakhs** by way of RTGS/NEFT to the following account of Cochin Shipyard Ltd, Kochi

Bank	State Bank of India
IFSC	SBIN0004062
Account No.	10319928321 of Cochin Shipyard Ltd.

13.2. The bidder shall submit the proof of such transfer along with the submission of technical bid.

13.3. This shall be returned after finalization of contract and upon receipt of Security deposit in accordance with clause 15 below, with respect to successful bidders; With respect to unsuccessful bidders, the same shall be returned within 15 days of issuance of PO/Contract.

13.4. Bidders belonging to Micro and Small Enterprises (MSE's) category are exempt from furnishing EMD subject to the bidders producing valid UDYAM Certificate and shall be duly verified by CSL. Bidders who fail to submit UDYAM Certificate along with the Techno-Commercial Offer shall not be considered eligible for EMD exemption.

13.5. In case the offer validity is extended on mutual consensus, the validity of EMD shall be mutually extended, EMD may be forfeited in the following cases:

- Bidder withdraws, amends, impairs or derogates from the tender, agreed conditions in any respect within the period of validity of his offer.
- Non-acceptance of order.

14. **प्रतिभूति जमा /SECURITY DEPOSIT**

14.1. The successful tenderer shall remit 5% of the value of the contract as security deposit within 15 days of receipt of the work order. This amount has to be remitted by way of demand draft or bank guarantee (in approved proforma of CSL) from any of the



**TENDER ENQUIRY NOTICE – IN-SITU MACHINING & DRILLING OF AZIMUTH THRUSTER FOUNDATIONS IN COMMISSIONING SERVICE OPERATIONAL VESSEL (CSOV)**

nationalized banks/ Scheduled Indian Bank, valid till the satisfactory completion of the entire work. The Security Deposit will be released after satisfactory completion of the contract on certification of nil liability to CSL by Officer-in Charge. The Security Deposit will not bear any interest.

**15. निष्पादन गारंटी/PERFORMANCE GUARANTEE**

- 15.1. The complete work carried out by the contractor shall be guaranteed against performance of work and/or poor workmanship for a period of one year from the date of completion of work. Any damage or failure due to defects in execution of the work for a period of 12 months from the date of completion of work, should such damage or failure occur within the guarantee period, the contractor shall rectify/rework the defect as applicable without any extra expenditure to CSL and such repaired work shall be guaranteed for a further period of one year from the date of repair.
- 15.2. Towards this, a performance guarantee equivalent to 5% of the value of the contract to be furnished by the contractor within 21 days of receipt of work order, by way of a bank guarantee (in approved proforma of CSL) from a nationalized bank / Scheduled Indian Bank valid till the expiry of the guarantee period. (Payment will be released only on submission of PBG)
- 15.3. PBG will be returned to the Contractor after one year from the date of completion of work on certification of nil liability to CSL by Officer-in charge.
- 15.4. Performance Guarantee is applicable for all bidders irrespective of MSME/NSIC registration for necessary coverage under the performance guarantee clause.

**16. परिसमापन क्षतिपूर्ति / LIQUIDATED DAMAGES**

- 16.1. The progress of work will be monitored against the mutually agreed detailed schedule referred in clause. Liquidated damages for delays in execution of the work envisaged as per this order, for any reason other than force majeure conditions, will be recovered at the rate of half percent (0.5%) of the total contract value of delayed work per week or part thereof, subject to a maximum of ten (10) percent of the basic value of the delayed work.

**17. आदेश रद्द करना और जोखिम अनुबंध / CANCELLATION OF ORDER AND RISK CONTRACTING**

- 17.1. In the event the contractor fails to complete the work promptly and satisfactorily as per the terms of the order, and if the work is delayed beyond the agreed schedule, CSL,

**TENDER ENQUIRY NOTICE – IN-SITU MACHINING & DRILLING OF AZIMUTH THRUSTER FOUNDATIONS IN COMMISSIONING SERVICE OPERATIONAL VESSEL (CSOV)**

without prejudice, reserves the right to cancel the order and get the work done at contractor's cost and the expenditure so incurred including any damage or loss will be recovered from him and the Security Deposit furnished by him is liable to be forfeited either in whole or in part.

17.2. In addition to above tender holiday will be imposed against the firm as per discretion of CSL.

18. **अप्रत्याशित घटना / FORCE MAJEURE**

18.1. Should failure in performance of any part of this contract arise from war, insurrection, restraint imposed by Government act or legislation of other statutory authority, from explosion, riot, legal lock-out, flood, fire, act of Govt. or any inevitable or unforeseen event beyond human control which will be construed as a reasonable ground for extension of time, CSL may allow such additional time as is mutually agreed to be justified by the circumstances of the case.

18.2. The occurrence / cessation of force majeure situation have to be informed with documentary evidence within 15 days from the date of occurrence / cessation.

19. **मध्यस्थता / ARBITRATION**

19.1. Any disputes arising during the currency of the contract shall, in the first instance be settled by mutual discussions and negotiations. The results of such resolution of dispute shall be incorporated as an amendment to the contract, failing which the parties can resort to arbitration.

19.2. If any dispute, disagreement or question arising out of or relating to or in consequence of the contract, or to its fulfillment, or the validity of enforcement thereof, cannot be settled mutually or the settlement of which is not herein.

Specifically provided for, then the dispute shall within thirty days from the date either party informs the other in writing that such disputes, disagreement exists, be referred to arbitration. The arbitrators shall be appointed and the arbitration proceedings shall be conducted in accordance with and subject to the Arbitration and Conciliation Act, 1996 (No. 26 of 1996) as amended from time to time and the decision of the Arbitrators shall be final and binding on the parties hereto. The arbitration will be done by a Board comprising one officer nominated by each party, and a mutually agreed Umpire. Each party shall bear its own cost of preparing and presenting its case. The cost of arbitration shall be shared equally by the parties unless the award provides otherwise. The



**TENDER ENQUIRY NOTICE – IN-SITU MACHINING & DRILLING OF AZIMUTH THRUSTER FOUNDATIONS IN COMMISSIONING SERVICE OPERATIONAL VESSEL (CSOV)**

enforcement of the award shall be governed by the rules and procedures in force in the State in which it is to be executed. Performance under this Contract shall however, continue during arbitration proceedings and no payment due or payable by the parties hereto shall be withheld unless any such payment is or forms a part of the subject matter of arbitration proceedings.

19.3. In case of disputes, the same will be subjected to the jurisdiction of courts at Ernakulam, Kerala, India only.

**20. क्षेत्राधिकार / JURISDICTION**

20.1. All questions, disputes or differences arising under/out of or in connection with this contract shall be subject to the jurisdiction of the Courts in Cochin.

**21. गोपनीयता खंड / SECRECY CLAUSE**

21.1. The CONTRACTOR shall be responsible to ensure that all persons employed by them in the execution of any work in connection with this contract are aware of the provisions of the official secrets act 1923 and to comply with the same. The CONTRACTOR shall also ensure secrecy of design, construction, equipment and completion of the vessel. Any information provided to you under this contract is to be treated as strictly confidential and is not to be disclosed to any person or persons not concerned therewith.

21.2. All documents under this Contract transferred between the parties shall be treated as UNCLASSIFIED unless explicitly marked.

21.3. The CONTRACTOR shall ensure that their organization, suppliers/ installation agency/test and trials teams etc. shall not communicate for use in advertising, publicity, sales release or in any other medium, system details, photographs and reproduction of equipment and their fitment on board.

21.4. SECRECY, Titles: Maps, layouts and photographs of the unit/plant including its surrounding regions showing vital installation for national security of CSL country shall not be published or disclosed to the third parties or taken out of the country without prior written approval of the CSL and upon execution of confidentiality agreements satisfactory to the CSL with such third parties prior to disclosure.

**TENDER ENQUIRY NOTICE – IN-SITU MACHINING & DRILLING OF AZIMUTH THRUSTER FOUNDATIONS IN COMMISIONING SERVICE OPERATIONAL VESSEL (CSOV)**

**22. श्रम कानून और विनियम /LABOUR LAWS AND REGULATIONS**

- 22.1. The Contractor shall undertake and execute the work with contract Labour only after taking license from the appropriate authority under the Contract Labour (Regulation & Abolition) Act 1970.
- 22.2. The Contractor shall observe and comply with the provisions of all labour and industrial laws and enactments and shall comply with and implement the provisions of the Factories Act, 1948, `Employees Provident Funds & Miscellaneous Provisions Act, 1952, Employees State Insurance Act, Payment of Gratuity Act, minimum Wages Act, Payment of Bonus Act, Contract Labour (Regulation and Abolition) Act and all other enactments as are applicable to him and his workmen employed by him. The Contractor shall inform CSL his license number from the Central Labour Commissioner.
- 22.3. All contract workmen, except those exempted under the respective Acts, shall necessarily be insured under the ESI scheme and be made members of the EPF Scheme from the day of their engagement as contract workmen in the Company. All such insured contract workmen should carry with them their ESI Identity Card for verification by the authorities. No contract workmen without a valid ESI Identity Card for verification by the authorities will be permitted to work in the company.
- 22.4. The Contractor shall submit the Compliance Certificate by means of uploading relevant documents such as Electronic Challan cum Receipt, Challans etc. as having remitted the contributions towards EPF/ESI in respect of their workers, in the goggle form provided for the purpose, every month so as to reach Welfare Section on or before 22nd of every month. Google form link: <https://forms.gle/3GidCgsP4jHhXDJt9>
- 22.5. The Contractor shall submit the Labour Reports>Returns as required by the Company from time to time in respect of their workmen in standard format to the concerned contracting officer so as to enable the same to reach Personnel Department by the 5th of every month. Delayed submission of the same shall attract penal interest /damages at the rate as levied by the respective authorities under the relevant Acts.
- 22.6. The Contractor shall maintain the records viz. Muster Roll, Acquaintance Roll with full details, Account books etc., in original. These are required for inspection by the concerned authorities under each scheme.
- 22.7. If the Contractor fails to pay any contributions, charges or other amounts payable under any of the aforementioned provisions of law, CSL shall deduct or adjust amounts equivalent to such contribution, charges or amounts from amount payable to him by CSL, including any deposit or amounts payable against bills and make payments on his account

**TENDER ENQUIRY NOTICE – IN-SITU MACHINING & DRILLING OF AZIMUTH THRUSTER FOUNDATIONS IN COMMISSIONING SERVICE OPERATIONAL VESSEL (CSOV)**

to the appropriate authority. He shall not be entitled to question or challenge such deductions, adjustments or payment made by CSL.

- 22.8. Any other amount payable under any law or in respect of any person employed by the Contractor, if not paid by him, shall be deducted or adjusted by CSL out of any amount payable to the Contractor including any Security Receipt and paid ever or withheld for payment by CSL.
- 22.9. The Contractor shall be fully responsible for the conduct and discipline of the workmen employed by him in the Company premises. If such workmen commit any misconduct or criminal act inside the Company, the Contractor shall take appropriate action against such workmen. The contractor shall abide by the instructions/ guidelines issued by the Company for maintenance of discipline and good conduct among the workmen employed by him.
- 22.10. All person who are engaged for various works in CSL either directly or through contractors, should produce the following documents prior to issuing their entry passes:
- 22.11. Passport/attested copy of passport with photo and address particulars. OR
- 22.12. Police clearance certificate with photo and address particulars. (Police clearance certificate to the effect that the concerned person is staying in the area of jurisdiction of the certificate issuing Police Station and that the person is not involved in any criminal offences as per the records available therein.)
- 22.13. Application and Declaration for enrolling under Employees Provident Fund and ESI Scheme - 3 individual passport size photographs and two copies of family photographs of the members.
- 22.14. **Contractors are requested to familiarize themselves with the labour rules & regulations prevailing in CSL including the labour wage pattern of contract labour as per the settlement between the trade unions & contractors.**

**23. आईएमएस दिशानिर्देश /IMS GUIDELINES**

23.1. CSL has implemented an Integrated Management System (IMS) consisting of Environmental Management system (EMS), Occupational Health and Safety Management System (OHSMS) and the Quality Management System (QMS) within the yard. As part of IMS, subcontractors shall comply with the following measures related to the Quality, Health, and Safety & Environment (QHSE) policy of CSL.

- 23.1.1. Meeting or exceeding customer requirements.
- 23.1.2. Assuring quality of the products and service.
- 23.1.3. Preventing occupational ill health & injuries.

**TENDER ENQUIRY NOTICE – IN-SITU MACHINING & DRILLING OF AZIMUTH THRUSTER FOUNDATIONS IN COMMISSIONING SERVICE OPERATIONAL VESSEL (CSOV)**

- 23.1.4. Ensuring safe work sites.
- 23.1.5. Conserving natural resources.
- 23.1.6. Preventing / minimizing air, water & land pollution.
- 23.1.7. Handling and disposal of Hazardous wastes safely.
- 23.1.8. Complying with statutory & regulatory and other requirements.
- 23.1.9. Developing skills and motivating employees.
- 23.2. Occupational Health, safety & Environmental requirements of CSL shall also include the following.
- 23.3. The contractor (or a sub-contractor performing work on behalf of the contractor) is deemed to comply with the Occupational health, safety and environmental policy of the company and also to all operational controls/standard operating procedures and shall undertake the work in total compliance with the requirements of the established Integrated Management System (IMS) of the company.
- 23.4. The Contractor shall undertake the work in total compliance with all applicable legal/statutory requirements related to occupational health, safety and environment effective in the state of Kerala.
- 23.5. It is the sole responsibility of the contractor to assure that any sub-contractor/s who shall perform works in company lands/facilities/worksites on behalf of the contractor, is also following all requirements related to the Integrated Management System of the company and the health/safety/environmental Rules effective in the state.
- 23.6. The contractor shall provide/implement and operate/practice all occupational health, safety and environmental management measures/facilities, for their period of contract, in their activities/at their work sites, which shall be required according to the IMS of the company or that required by the health/safety/environmental Rules established and effective in the state, at their own cost.
- 23.7. If any contractor failed to comply with or violated any clauses/requirements of occupational health, safety and environmental Rules effective in the state, in their activities or at work sites and the same shall be exposed to the government or any competent authorities upon inspections, the contractor shall be solely responsible for all liabilities caused by his/her action and shall be responsible for paying the penalty and taking stipulated corrective actions insisted by the authorities within the specified time, at their own cost. Any liability to the company in this regard needs to be compensated by the contractor.

**TENDER ENQUIRY NOTICE – IN-SITU MACHINING & DRILLING OF AZIMUTH THRUSTER FOUNDATIONS IN COMMISSIONING SERVICE OPERATIONAL VESSEL (CSOV)**

23.8. Upon completion of the work, contractor shall clear the area and shall not leave any Occupational health/safety/environmental liabilities to the company, from their activities at the worksites.

23.9. Any clarification related to IMS requirements of the yard, may be obtained by the contractor from the DGM (In charge of work) or the authorized representative of the contract, prior to the commencement of work.

**24. बिजली नियम और विनियमन / ELECTRICITY RULES AND REGULATION**

24.1. The contractor shall adhere to the various rules in respect of electrical installation as per the Indian Electricity Rules and Regulations and Electrical Inspectorate Standards in order to make sure that men and materials are safe from hazards.

**25. गोपनीयता खंड / SECRECY CLAUSE**

25.1. The CONTRACTOR shall be responsible to ensure that all persons employed by them in the execution of any work in connection with this contract are aware of the provisions of the official secrets act 1923 and to comply with the same. The CONTRACTOR shall also ensure secrecy of design, construction, equipment and completion of the vessel. Any information provided to you under this contract is to be treated as strictly confidential and is not to be disclosed to any person or persons not concerned therewith.

25.2. All documents under this Contract transferred between the parties shall be treated as UNCLASSIFIED unless explicitly marked.

25.3. The CONTRACTOR shall ensure that their organization, suppliers/ installation agency/test and trials teams etc. shall not communicate for use in advertising, publicity, sales release or in any other medium, system details, photographs and reproduction of equipment and their fitment on board.

25.4. SECRECY, Titles: Maps, layouts and photographs of the unit/plant including its surrounding regions showing vital installation for national security of CSL country shall not be published or disclosed to the third parties or taken out of the country without prior written approval of the CSL and upon execution of confidentiality agreements satisfactory to the CSL with such third parties prior to disclosure.

**26. HEALTH, SAFETY & ENVIRONMENT CONTRACT GUIDELINES FOR OEMS /TURNKEY JOBS / SUB CONTRACT WORKS INSIDE CSL**

**INTRODUCTION**

26.1. CSL is the largest public sector shipyard in India in terms of dock capacity, and caters to

**TENDER ENQUIRY NOTICE – IN-SITU MACHINING & DRILLING OF AZIMUTH THRUSTER FOUNDATIONS IN COMMISSIONING SERVICE OPERATIONAL VESSEL (CSOV)**

clients engaged in the defence sector in India and clients engaged in the commercial sector worldwide.

- 26.2. CSL is committed to provide safe and healthy work environment for the prevention of work-related injury and ill health by following the best practices in safety. CSL is certified Occupational Health and Safety management System and Environmental Management system under ISO standards/international standard.
- 26.3. Many of the works of CSL at various sites are executed by the sub-contractors. During these works, sub-contractors personnel are likely to be exposed to different types of hazards. Similarly unsafe acts of contractor's personnel may create hazards for CSL staff or workmen of other contractors working at the site. Such unsafe acts may also pose danger to the existing installations and even to members of public.
- 26.4. CSL ensures that the requirements of its HSE Management System are conveyed by contractors and their workers. This guide is prepared to facilitate safe working during execution of contract works. The General guide lines and HSE requirements are given below for compliance in CSL.

**GENERAL GUIDELINES**

- 26.5. OEMs/Turnkey jobs /Contractors are selected to work inside the CSL based on their track record.
- 26.6. Along with the contract order/Registration, a copy of the HSE Safety Handbook (CSL/QMS/S&F/SOP 02 – Refer CSL Website) of CSL is given to all contractors. The details of all HSE requirements to be followed in CSL for the various types of work are detailed in the hand book. The OEMs/Turnkey jobs /Contractors shall go through all the details and strictly follow the relevant HSE guidelines for their work. In case of any doubt the same shall be clarified from Chief Safety Officer (CSO). Being ignorant of these HSE requirements will not be treated as an excuse for any HSE violations during course of work.
- 26.7. OEMs/Turnkey jobs /Contractors workmen are given a multilingual HSE induction and Emergency Response training. The individual passes for contractors and their workers are issued only after successful completion of this training. The passes are revalidated every year after successful completion of refresher training. Training requirements of other roles of the subcontractor's staff shall be complied as per the CSL requirements time to time.
- 26.8. Before start of any work, the CSL officer in charge explains the scope of work and the safety precautions, hazards, PPE usage as per PPE matrix of CSL, Work Instructions, SOPs, Emergency responses to the contractor and his workers. Only trained worker with necessary skills are allowed to work as per the requirement. Necessary PPEs for the work



**TENDER ENQUIRY NOTICE – IN-SITU MACHINING & DRILLING OF AZIMUTH THRUSTER FOUNDATIONS IN COMMISIONING SERVICE OPERATIONAL VESSEL (CSOV)**

are to be arranged by the contractor.

- 26.9. Workmen shall have Cotton coverall with identifiable logo on the dress. Supervisors, fire watch man if required, safety staff and other workforce shall be deployed as per CSL guide lines.
- 26.10. The site work supervisor of the OEMs/Turnkey jobs /Contractors shall be ensured that works are being carried out by CSL HSE requirements on daily basis and till the completion of works. The safe start and safe end requirements shall be verified by the site work supervisor on daily basis.
- 26.11. OEMs/Turnkey jobs /Contractors HSE performance will be evaluated on HSE matters as per the CSL policies time to time.
- 26.12. During the course of work if any HSE violation is noticed the same is dealt as per the Rewards and Reprimand (R&R) Policy of CSL.
- 26.13. HSE Plan to be submitted to S&F Dept while commencing the work in CSL and shall be resubmitted in every year.

**HSE REQUIREMENTS**

- 26.14. The OEMs/Turnkey jobs /Contractors shall take all safety precautions during the execution of awarded work and shall maintain and leave the site safe at all times. At the end of each working day and at all times when the work is temporarily suspended, he shall ensure that all materials, equipment and facilities will not, cause damage to existing property, personal injury or interfere with the other works of the project or Station.
- 26.15. The OEMs/Turnkey jobs /Contractors shall provide and maintain all type of lights, guards, fencing, warning signs, caution boards and other safety measures for vigilance as and where necessary or as required by the CSL officer-in-charge or Safety staff. The caution boards shall also have appropriate symbols.
- 26.16. Where Permit to work (PTW) is required, the work has not started without obtaining the necessary permit and the PTW requirements are followed strictly throughout the work.
- 26.17. For Project specific or non-routine work on the existing installations, separate Job Safety Assessment (JSA) is to be prepared by the contractor, cleared by the Dept in charge and approval obtained from CSO before start of work. The work shall be executed through Notification Control Procedure (NCS).
- 26.18. A separate HSE plan will be required for the new projects in the yard or any turnkey projects. It shall be in line with CSL HSE requirements and same shall be routed through respective S&F dept and approved by respective HOD.
- 26.19. OEMs/Turnkey jobs /Contractors shall hold toolbox talks with his workers on daily basis

**TENDER ENQUIRY NOTICE – IN-SITU MACHINING & DRILLING OF AZIMUTH THRUSTER FOUNDATIONS IN COMMISIONING SERVICE OPERATIONAL VESSEL (CSOV)**

to convey matters regarding the Safety aspects of the work.

- 26.20. The OEMs/Turnkey jobs /Contractors shall plan his operations so as to avoid interference with other Departmental works and other Sub-Contractors at the site. In case of any interference, requires, coordination shall be sought by the contractor from the Department for safe and smooth execution of work. This shall be done through CSL executing officer.
- 26.21. The OEMs/Turnkey jobs /Contractors shall at all times keep their work spot, site office and surroundings clean and tidy from rubbish, scrap, surplus materials and unwanted tools and equipment. Welding cables, hoses and electrical cables shall be so routed as to allow safe way to all concerned.
- 26.22. All waste generated in course of the work shall be segregated as per the yard requirements and shall be disposed at the respective collection pallets / points of the work areas as the case may be. Any kind of pollution made by the subcontractor shall attract the reprimand proceedings.
- 26.23. All necessary precautions shall be taken to prevent outbreak of fires at the work site. Adequate provisions shall be made to prevent the possibility of fires and ensure the availability of fire extinguishers at site.
- 26.24. The OEMs/Turnkey jobs /Contractors shall be held responsible for non-compliance of any of the safety measures and delays, implications, injuries, fatalities and compensation arising out of such situations of incidents including statutory obligations.

**27. सामान्य शर्ते / GENERAL CONDITIONS**

- 27.1. Quality of workmanship shall conform to the specification/ standards laid down by CSL
- 27.2. CSL reserves the right to award the work to more than one contractor or to take over partially or fully the work depending upon the scheduled requirements.
- 27.3. Compliance of all statutory safety requirements and other safety rules stipulated by CSL and other applicable statutory bodies shall be the responsibility of the Contractor while working at CSL premises. The Contractor should ensure that their workmen and staff are adequately covered under Insurance.
- 27.4. Damages caused to the Shipyard properties/tools/accessories should be rectified by the Contractor at his cost or proportional recoveries will be made from the contractor while passing their bills for payment.
- 27.5. Cochin Shipyard Limited reserves the right to terminate the Contract at short notice in case the Contractor's performance is found not satisfactory with regard to progress of work, quality, time factor, labour dispute with their workers, poor safety records etc., and other contractual obligations. No claim whatsoever will be entertained by Cochin



**TENDER ENQUIRY NOTICE – IN-SITU MACHINING & DRILLING OF AZIMUTH THRUSTER FOUNDATIONS IN COMMISIONING SERVICE OPERATIONAL VESSEL (CSOV)**

Shipyard Limited on this account.

- 27.6. The Contractor shall have to engage men on round the clock basis and also on Sundays and holidays, if required. Work has to be completed to the satisfaction of Cochin Shipyard representative deputed for the job. The job should be completed at the time specified by the representative deputed for the job for each stage of work.
- 27.7. The Contractor shall indemnify CSL and CSL's personnel against any claims arising out of accidents or injuries to workmen or other persons or damage to other property which may arise during the execution of the contract or from breach of any Law or Regulation prior to delivery and acceptance of the items at CSL.
- 27.8. It is also to be understood by the Contractor that Cochin Shipyard Limited does not bind itself to give the Contractor any regular or specific quantity or area of work and it shall be done at the sole discretion of CSL depending on the prevailing site conditions and other limiting factors and no claim on this account from the contractor shall be entertained.
- 27.9. The Contractor shall also be governed by the General Conditions of Contract of CSL, General Safety Rules and other relevant labour laws.
- 27.10. The contractor shall arrange to collect and clean up every day all waste, scraps; debris, etc. generated by the work men while working on-board the vessel and other locations and dispose the same suitably at his cost to the full satisfaction of CSL. In case any failure on his part to comply with this requirement, CSL will arrange the required cleaning entirely at the contractors cost.
- 27.11. The upper age limit of all workers and supervisors employed by the contractor and those contractors who do or supervise the job themselves shall be as per the prevailing rules of CSL.
- 27.12. General Manager (SB) or his authorized representative will be the Officer-in-charge of this Contract.
- 27.13. Withdrawal of the quotation after it is accepted or failure to make contract execution within the stipulated completion period will entail cancellation of the order and forfeiture of EMD/ Security Deposit, if any/ and or risk purchase.
- 27.14. Subcontracting to other vendors shall be only after written intimation and approval of competent CSL authorities. Vendor shall not delegate or subcontract any of its obligations under the agreement without CSL's written consent. Vendor will remain liable for all subcontracted obligations and all acts or omissions of its subcontractors.
- 27.15. The procedures of work, standard operating procedures of work including documents like welding procedure specifications developed by CSL are intellectual property of CSL. Vendors shall not use or copy the procedure in any format without the written consent of

**TENDER ENQUIRY NOTICE – IN-SITU MACHINING & DRILLING OF AZIMUTH THRUSTER FOUNDATIONS IN COMMISSIONING SERVICE OPERATIONAL VESSEL (CSOV)**

competent authorities of CSL.

27.16. Vendor shall return the CSL resources to CSL immediately after provision of all deliverables and services or any termination of the agreement.

27.17. Conditional discounts, if any, will not be reckoned for tender evaluation/comparison purposes. However the same will be considered at the time of placement of purchase order if the firm turns out to be lowest bidder.

**28. कार्मिकों की सुरक्षा और प्राथमिक चिकित्सा /SAFETY OF PERSONNEL AND FIRST AID**

28.1. The contractor shall be entirely responsible for the safety of all the personnel employed by him on the work. In this regard, he may adopt all the required safety measures and strictly comply with the safety regulations in force.

28.2. The Contractor may arrange to suitably insure all his workmen/ other personnel in this regard. CSL will not be responsible for any injury or illness to the Contractor's workmen/other personnel during execution of the works due to whatsoever reasons.

28.3. In this regard, the Contractor will have to fully indemnify CSL against any claims made by his workmen/other personnel.

28.4. The Contractor shall provide and maintain so as to be readily accessible during all working hours, a first aid box with prescribed contents at every place where he employs contract labour for executing the works.

**29. अधिलेखन और सुधार / OVERWRITING & CORRECTIONS**

29.1. Tenders shall be free from overwriting or erasures. Corrections and additions, if any, shall be duly attested and a separate list of such corrections shall be attached with the offer.)

29.2. All terms and conditions, other than those mentioned above, contained in the Enquiry specification and drawings (Annexure I), Cochin Shipyard Ltd - General Terms and conditions (Annexure II) and other annexure pertaining to this tender shall also be attested by the bidder as a token of acceptance.

29.3. CSL reserves the right to reject any or all bids without assigning any reasons whatsoever and or based on the past unsatisfactory performance by the bidders at CSL/other PSE's/Government Departments. After issuing the work order, CSL reserves the right to terminate the contractor if the performance of the contractor is not found satisfactory. The decision of CSL regarding the same shall be final and conclusive.



**कृते उप महाप्रबंधक / For Deputy General Manager  
आउटसोर्सिंग विभाग / Outsourcing Department**

**TENDER ENQUIRY NOTICE – IN-SITU MACHINING & DRILLING OF AZIMUTH THRUSTER FOUNDATIONS IN COMMISSIONING SERVICE OPERATIONAL VESSEL (CSOV)**

**ANNEXURE-II**

कोचीन शिपयार्ड लिमिटेड / COCHIN SHIPYARD LIMITED  
कोच्ची / KOCHI-682015

**आउटसोर्सिंग विभाग / OUTSOURCING DEPARTMENT**  
**सामान्य शर्ते / GENERAL CONDITIONS**

**सामान्य शर्ते / GENERAL CONDITIONS**

- a. The complete work to be carried out with the highest degree of workmanship under the guidance of CSL, Classification Society/ Ship owner, or any other agency nominated by the Shipyard (when specifically indicated in the technical specifications).
- b. Quality of workmanship shall conform to the specification/ standards laid down by CSL
- c. Any minor modifications, resulting from the change in statutory regulations prevailing at the time of final inspection of work by Classification Society, to be carried out by the Contractor free of cost. In case of rework/modification/additional work, written consent is to be obtained from the Officer-in-Charge before commencement of the work.
- d. Contractor shall carry out the complete work in accordance with Shipyard's approved drawings. Any minor modifications from drawing or any other work or supply of material, which is not specified hereunder, but is considered incidental and essential for the successful completion of the job, shall be carried out by the Contractor without any additional charge.
- e. CSL reserves the right to award the work to more than one contractor or to take over partially or fully the work depending upon the scheduled requirements.
- f. Contractor shall execute, during or after completion of the work, any minor job connected with the work, should it be considered necessary by Shipyard and/or Classification Society
- g. Material supplied by CSL may not be in the required size and shape. These may be cut and prepared after proper nesting by the Contractor. Special care to be taken to reduce wastages. Shortage of any material (supplied by CSL) arising out of excess wastages due to improper planning shall have to be made up by Contractor free of cost.
- h. Contractor should strictly comply with the welding specification as mentioned in the drawing.
- i. The Contractor shall have to engage men on round the clock basis and also on Sundays and holidays, if required. Work has to be completed to the satisfaction of Execution officer of CSL. The job should be completed at the time specified by the contract depending on the loaded quantity.

**TENDER ENQUIRY NOTICE – IN-SITU MACHINING & DRILLING OF AZIMUTH THRUSTER FOUNDATIONS IN COMMISIONING SERVICE OPERATIONAL VESSEL (CSOV)**

- j. Compliance of all statutory safety requirements and other safety rules stipulated by CSL and other applicable statutory bodies shall be the responsibility of the Contractor while working at CSL premises. The Contractor should ensure that their workmen and staff are adequately covered under Insurance.
- k. Cochin Shipyard Limited reserves the right to terminate the Contract at short notice in case the Contractor's performance is found not satisfactory with regard to progress of work, quality, time factor, labour dispute with their workers, poor safety records etc., and other contractual obligations. No claim whatsoever will be entertained by Cochin Shipyard Limited on this account.
- l. The Contractor shall indemnify CSL and CSL's personnel against any claims arising out of accidents or injuries to workmen or other persons or damage to other property which may arise during the execution of the contract or from breach of any Law or Regulation prior to delivery and acceptance of the items at CSL.
- m. The Contractor shall also be governed by the General Conditions of Contract of CSL, General Safety Rules and other relevant labour laws.
- n. The upper age limit of all workers and supervisors employed by the contractor and those contractors who do or supervise the job themselves shall be as per the prevailing rules of CSL.
- o. General Manager (SB) or his authorized representative will be the Officer-in-Charge of this Contract.
- p. Withdrawal of the quotation after it is accepted or failure to make contract execution within the stipulated completion period will entail cancellation of the order and forfeiture of EMD/ Security Deposit, if any/ and or risk purchase.
- q. Subcontracting to other contractors shall be only after written intimation and approval of competent CSL authorities. Contractor shall not delegate or subcontract any of its obligations under the agreement without CSL's written consent. Contractor will remain liable for all subcontracted obligations and all acts or omissions of its subcontractors.
- r. The procedures of work, standard operating procedures of work including documents like welding procedure specifications developed by CSL are intellectual property of CSL. Contractor shall not use or copy the procedure in any format without the written consent of competent authorities of CSL.
- s. Conditional discounts, if any, will not be reckoned for tender evaluation/comparison purposes. However the same will be considered at the time of placement of purchase order if the firm turns out to be lowest bidder.

**TENDER ENQUIRY NOTICE – IN-SITU MACHINING & DRILLING OF AZIMUTH THRUSTER  
FOUNDATIONS IN COMMISSIONING SERVICE OPERATIONAL VESSEL (CSOV)**

- t. Any particulars/literature/information/certificates required by the Shipyard in connection with the work is to be forwarded free of cost.
- u. All correspondence with the Shipyard to be in English language. All documents and plans to be in English and in metric units.



कृते उप महाप्रबंधक / For Deputy General Manager  
आउटसोर्सिंग विभाग / Outsourcing Department

**ANNEXURE III**

**कार्य क्षेत्र / SCOPE OF WORK**

**IN-SITU MACHINING & DRILLING OF AZIMUTH THRUSTER FOUNDATIONS IN COMMISSIONING SERVICE OPERATIONAL VESSEL (CSOV)**

**1. INTRODUCTION**

Cochin Shipyard Limited (CSL) is constructing two Commissioning Service Operational Vessels (CSOVs) with yard numbers BY.151 and BY.152. These vessels are methanol-based dual-fuel electric hybrid vessels equipped with dynamic positioning capabilities facilitated by:

- 2 Azimuth Thrusters (Aft)
- 1 Swing-Up Thruster (Fwd)
- 2 Tunnel Thrusters (Fwd)

**2. VESSEL PARTICULARS**

Length Overall (Excl. Boat Landing)	Approx. 92.10 M
Length Overall (Incl. Boat Landing):	Approx. 93.40 M
Length Between Perpendiculars (P.P.):	83.10 M
Breadth Moulded (MLD):	19.60 M
Breadth Over Bridge Wings:	22.40 M
Depth to Freeboard Deck (from Baseline):	7.50 M
Design Draught:	5.00 M
Maximum Draught:	Approx. 5.50 M

**TENDER ENQUIRY NOTICE – IN-SITU MACHINING & DRILLING OF AZIMUTH THRUSTER FOUNDATIONS IN COMMISSIONING SERVICE OPERATIONAL VESSEL (CSOV)**

### 3. SCOPE OF WORK

#### 3.1 MACHINING OF AZIMUTH THRUSTER FOUNDATIONS

- a) The scope of work involves the in-situ machining of the foundation for the Azimuth Thruster, as per the drawings and tolerances detailed in Appendix - D.
- b) **Machining Requirements**
  - Machining is to be performed on the inner circular area of the Azimuth Thruster foundations.
  - This will have to be carried out in-situ in overhead position once the foundations are welded on to the hull block.
- c) **Number of Foundations**
  - The vessel contains two foundations for Azimuth Thrusters.
  - The scope of work includes the machining of 02 foundation for azimuth thruster.
- d) **Tolerance Specifications**
  - Flatness Tolerance: 1 mm
  - Surface Roughness: Ra3.2
- e) **Machine Setting**
  - Centreline of the circular seat will be provided by CSL.
  - The contractor is responsible for completing the remaining machine setup and adjustments based on this centreline.

#### 3.2 DRILLING OF AZIMUTH THRUSTER FOUNDATIONS

- a) The scope of work involves the in-situ drilling of foundation bolt holes for the Azimuth Thruster, as per the drawings and tolerances specified in Appendix - C.
- b) Position of holes will be marked by CSL.
- c) **Number of Holes**
  - Per Seat: 30 holes
  - Per Vessel: 2 seats (60 holes per vessel)
- d) **Hole Specifications:**
  - Size: 30 mm
  - Tolerance: 0.5 mm



**TENDER ENQUIRY NOTICE – IN-SITU MACHINING & DRILLING OF AZIMUTH THRUSTER FOUNDATIONS IN COMMISSIONING SERVICE OPERATIONAL VESSEL (CSOV)**

**4. JOB DESCRIPTION**

SL.NO	DESCRIPTION	TOTAL QUANTITY
1	Machining of Azimuth Thruster Foundation	2 Foundations
2	Drilling of Bolt Holes in the Azimuth Thruster Foundation (30 holes per foundation)	60 Holes

**5. SCOPE OF CONTRACTOR**

- 5.1 The contractor is responsible for providing all necessary tools, accessories, jigs, and fixtures required for the execution of the work.
- 5.2 The contractor must ensure that all machining tolerances are met as specified. The contractor is required to demonstrate compliance to CSL personnel, CSL QC, owner representatives, and class surveyors. All tools used to prove these tolerances must be calibrated and supported by relevant certificates.
- 5.3 Before beginning the machining process, all applicable dimensional checks must be verified and confirmed with CSL personnel. Any deviations must be reported in advance.
- 5.4 Approval from CSL personnel must be obtained before the start of each phase of the operation.
- 5.5 The contractor is responsible for performing hot work (cutting, welding, dry survey for installation, and removal of machinery/equipment) and any other related tasks required for the project.
- 5.6 The work must be completed to the full satisfaction of CSL personnel, owner representatives, and class surveyors.
- 5.7 The contractor is responsible for procuring all items necessary for the successful completion of the work, excluding those already provided under CSL's scope

**6. SCOPE OF CSL**

- 6.1 Centre Point of the thruster foundation will be established and given by CSL.
- 6.2 Marking of all the areas to be machined, marking of bolt holes.
- 6.3 Verifying dimensions prior to each stage of operation.



**TENDER ENQUIRY NOTICE – IN-SITU MACHINING & DRILLING OF AZIMUTH THRUSTER FOUNDATIONS IN COMMISIONING SERVICE OPERATIONAL VESSEL (CSOV)**

- 6.4 Conducting survey for each stage of operation after the receipt of request from the contractor.
- 6.5 Gas, Compressed air, Electricity and Water will be provided at predetermined locations free of cost. Connection from switch board/cock assembly of gas, air and water to be arranged by the contractor.
- 6.6 Service of CSL Cranes, forklifts if required will be made available subject to availability at free of cost.
- 6.7 Staging above 3m height.
- 6.8 Arranging QC/ Owner reps/class surveyors for inspection and survey.

**7. SAFETY/STATUTORY RESPONSIBILITY**

- 7.1 The contractor shall be entirely responsible for the safety of all the personnel employed by him on the work. In this regard, he should adopt all the required safety measure and strictly comply with the safety regulations in force. A copy of CSL's "Safety Rules for Contractors (Revised)" is available with Outsourcing Department for reference.
- 7.2 The Contractor should arrange to suitably insure all his workmen/other personnel in this regard. CSL will not be responsible for any injury or illness to the Contractor's workmen/other personnel during execution of the works due to whatsoever reasons.
- 7.3 In this regard, the Contractor will have to fully indemnify CSL against any claims made by his workmen/other personnel.
- 7.4 The Contractor shall provide and maintain so as to be readily accessible during all working hours, a first aid box with prescribed contents at every place where he employs contract labour for executing the works.



कृते उप महाप्रबंधक / For Deputy General Manager  
आउटसोर्सिंग विभाग / Outsourcing Department

**ANNEXURE- IV**

**तकनीकी वाणिज्यिक जांच सूची / TECHNO COMMERCIAL CHECK LIST**

**(To be submitted by the bidder)**

**TENDER NO. SB-OSD/CSOV/921/2025 Dtd: 04-02-2025**

**FIRM NAME:**

(Bidders may confirm acceptance of the Tender Conditions/deviations if any to be specified)

SL. No	Tender Enquiry Requirements	Confirmation from bidder ( <u>strike off whichever is not applicable</u> )	Specific comments /Remarks
1	Scope of work as per Technical Specification/Drawings/ General Terms & conditions (Annexure III)	Agreed as per tender /Do not agree	
2	Whether technical bid & two price bids are submitted in separate PDFs?	Yes / No	
3	Schedule of work as specified in technical specification/ price bid of this tender is acceptable	Yes/ No	
4	Submission of Information/Documents with offer	Submitted/Not submitted	
5	Submission of MSME and NSIC registration document with offer	Submitted/Not submitted	
a	Specify the current status of the firm	MSME/MSE/Startup	
6	Offer Validity (date)	90days - Agreed as per tender/Do not agree	
7	Completion period as mentioned in the tender enquiry is acceptable	Yes/ No	
8	Taxes & Duties	Specified/included in Price	
9	Payment terms - confirm		
a	Any others (Specify details)		

**TENDER ENQUIRY NOTICE – IN-SITU MACHINING & DRILLING OF AZIMUTH THRUSTER FOUNDATIONS IN COMMISIONING SERVICE OPERATIONAL VESSEL (CSOV)**

10	Price shall remain firm and fixed and No Escalation in prices after awarding of contract	Agreed as per tender/Do not agree	
11	Termination of contract/risk purchase as per relevant clause in the terms & conditions of tender enquiry is acceptable	Yes / No	
12	Force Majeure	Agreed as per tender/Do not agree	
13	Liquidated damages and cancellation of contract	Agreed as per tender/Do not agree	
14	Arbitration & Jurisdiction clauses	Agreed as per tender/Do not agree	
15	Confirm all other terms and conditions of our enquiry are acceptable.	Confirmed/Not confirmed	
16	Confirm, un-priced price bid (price bid without price) is submitted with Part – I bid	Confirmed/Not confirmed	
17	Mode of submission of tender	Direct / Email	
18	Fully aware about the safety, general rules, regulations, standards, validity of offers and price, entry pass eligibilities.	Yes / No	
19	Is your firm registered under TReDS	Yes/No	
20	Is your firm registered as vendor in CSL	Yes/No	
21	Do your firm have valid registration under statutory schemes such as ESI / EPF	Yes/No	
22	Deviations from Tender conditions	No Deviations /Deviations are specified	

हस्ताक्षर / Signature:

ठेकेदार का पता / Address of the Contractor

मुहर / Seal:

**TENDER ENQUIRY NOTICE – IN-SITU MACHINING & DRILLING OF AZIMUTH THRUSTER FOUNDATIONS IN COMMISIONING SERVICE OPERATIONAL VESSEL (CSOV)**

**ANNEXURE-V**

**मूल्य बोली प्रारूप / PRICE BID FORMAT**

**TENDER NO. SB-OSD/CSOV/921/2025 Dtd: 04-02-2025**

**IN-SITU MACHINING & DRILLING OF AZIMUTH THRUSTER FOUNDATIONS IN COMMISIONING SERVICE OPERATIONAL VESSEL (CSOV)**

SL.NO	DESCRIPTION OF WORK	TOTAL AMOUNT (INR)
1	Machining of One Azimuth Thruster Foundation as per scope of work.	
2	Drilling of Bolt Holes in One Azimuth Thruster Foundation (30 Holes)	
3	<b>SUB-TOTAL AMOUNT OF ONE FOUNDATION (SUM OF SL.NO 1 + SL. NO.2)</b>	
4	<b>GST .....% HSN CODE.....</b>	
5	<b>TOTAL AMOUNT FOR ONE FOUNDATION (SUM OF SL.NO 3 + SL. NO 4)</b>	
6	<b>GRAND TOTAL AMOUNT FOR TWO FOUNDATION 2* (SL.NO. 5)</b>	



**TENDER ENQUIRY NOTICE – IN-SITU MACHINING & DRILLING OF AZIMUTH THRUSTER FOUNDATIONS IN COMMISIONING SERVICE OPERATIONAL VESSEL (CSOV)**

Grand Total amount (in words)

Rupees.....  
.....  
.....

**NOTE:**

- A. L1 will be determined based on Sub total amount **SL.No.3** Excluding GST.
- B. GST as per the prevailing rate will be paid.
- C. L1 declaration will be based on the price bid verification by CSL finance department as per the calculation specified.
- D. The scope of work involves the in-situ drilling of foundation bolt holes for the Azimuth Thruster ie, 30 holes per foundation.**
- E. Rate quoted shall be inclusive of labor costs, handling charge, sorting, Equipment's, Tools & tackles, consumable charges, part naming and any other cost included for the satisfactory completion of all works as specified in the scope of work mentioned at Annex-III.

Signature of Contractor/authorized signature  
of firm or agency:

Name of contractor or authorized signatory of  
firm/agency:

Designation:

Address:

Contact No:



**TENDER ENQUIRY NOTICE – IN-SITU MACHINING & DRILLING OF AZIMUTH THRUSTER FOUNDATIONS IN COMMISSIONING SERVICE OPERATIONAL VESSEL (CSOV)**

**APPENDIX- A**

**COMPLIANCE MATRIX**

<u>Clause No.</u>	<u>Compliance/ Deviation</u>

**Notes:**

1. If offer is not fully conforming to the requirements given in any clause of this specification, the deviation shall be stated in detail against the particular clause in the Compliance matrix.

**TENDER ENQUIRY NOTICE – IN-SITU MACHINING & DRILLING OF AZIMUTH THRUSTER FOUNDATIONS IN COMMISSIONING SERVICE OPERATIONAL VESSEL (CSOV)**

**APPENDIX - B**

**FORMAT FOR FINANCIAL CAPABILITY**

Sl. No.	Last three Financial Year	Annual Turnover	Profit after Tax (PAT)
1	Year 2021-22		
2	Year 2022-23		
3	Year 2023-24		

To be signed by the Authorized Signatory of the Applicant with Name, Designation, seal and date.

**Certificate from Chartered Accountant:**

This is to certify that \_\_\_\_\_ (name of the Firm) has received the payments shown above against the respective years and as computed.

Name of the Authorized Signatory representing Auditing firm:

Designation:

Name of firm (Chartered Accountant):

Signature of the Authorized Signatory:

Seal of Audit firm



**TENDER ENQUIRY NOTICE – IN-SITU MACHINING & DRILLING OF AZIMUTH THRUSTER FOUNDATIONS IN COMMISIONING SERVICE OPERATIONAL VESSEL (CSOV)**

**APPENDIX-C**

**PERFORMANCE EVALUATION FORM**

Parameters	Evaluation Grade Points Awarded (Grade Points X Weightage)					
	Grade	Excellent	Good	Average	Bad	Very Poor
	Weightage	5	4	3	2	1
Timely Completion as per Project schedule	10					
Work Planning & Coordination	2					
House Keeping and HSE	2					
Responsiveness to critical and complex works	2					
Overall Quality Management	2					
Integrity and Professionalism	2					
<b>Total Grade Points</b> (sum of points in each grade)	<b>20</b>					
Grand total of grade points awarded (Max 100)						

**Points to be considered during evaluation**

Timely Completion as per Project schedule	Completion of work within stipulated time, including class surveys & till submission of proper quotation. (No Reworks/Survey failures)
Work Planning & Co-ordination	Planning of (material, labour & machinery) for smooth execution of work, coordination with multiple agencies/stakeholders, Pro-active approach in avoiding hindrance of work, Supervisory skills, communication etc.
Responsiveness to critical and complex works	Willingness to execute complex works understanding the importance of the work for CSL, deployment of adequate workers in time & round the clock in critical tasks.
Overall Quality Management	Quality of Work, No of QC/Class survey points, Re-works, RT/Survey Failures, quality of manpower, supervisors etc. to be considered
House Keeping and HSE	Adherence to CSL HSE policies and instructions especially based on Number of Unsafe acts/ near misses ,use of PPEs, commitment & continuing practices for good housekeeping at site including waste management, daily tool box meetings at site.
Integrity and Professionalism	Responsiveness & commitment to work, uniforms to workers, appropriate & polite behaviour at site, ethics in preparation of quotations, corrections in quotation, proper documentation.



**TENDER ENQUIRY NOTICE – IN-SITU MACHINING & DRILLING OF AZIMUTH THRUSTER FOUNDATIONS IN COMMISIONING SERVICE OPERATIONAL VESSEL (CSOV)**

Signature (CSL Officer in-Charge)	
Name & Design	



**DETAILS OF MAIN FOUNDATION RING**

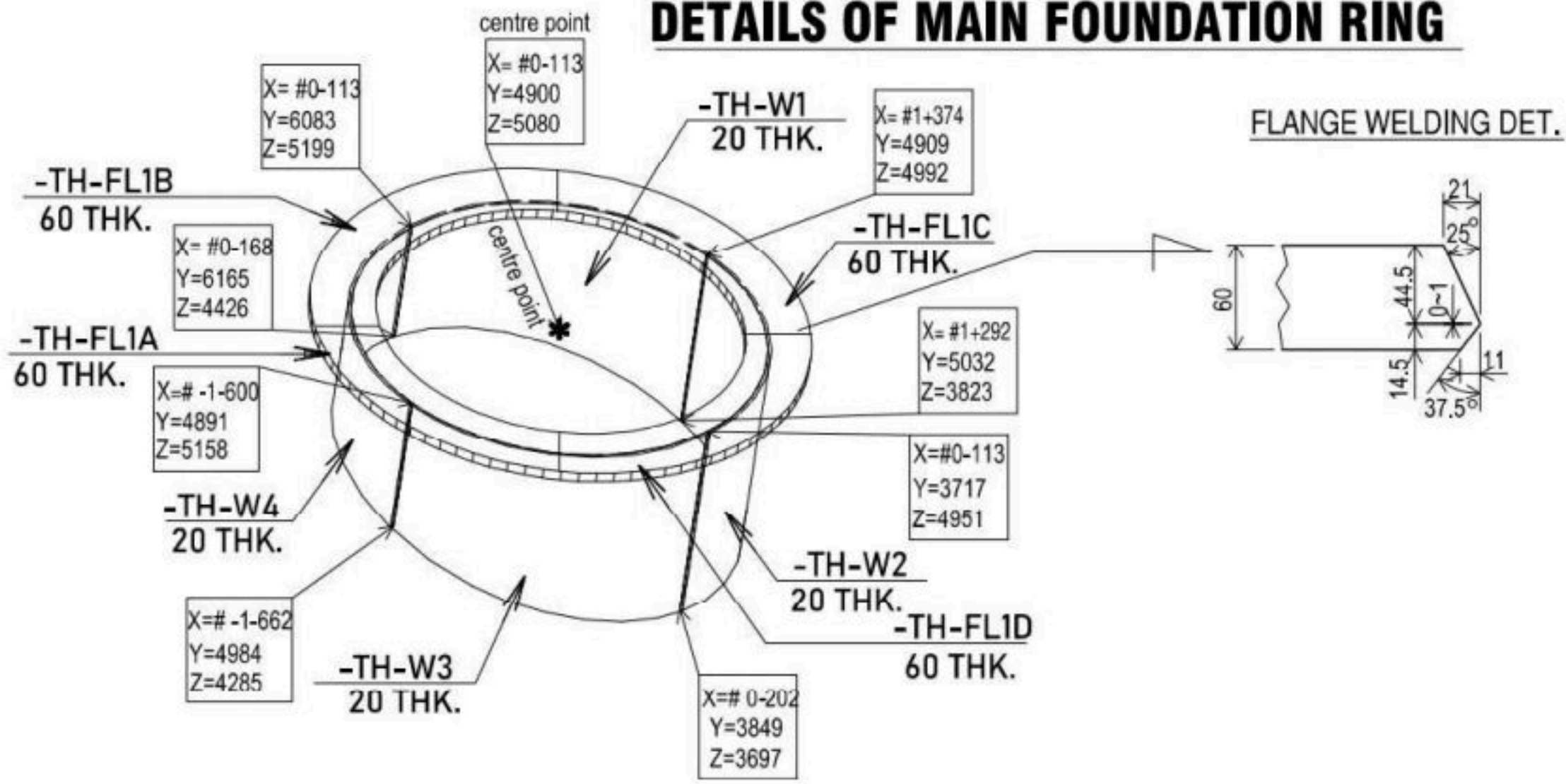

**SEC. AT FR.FR0-113**

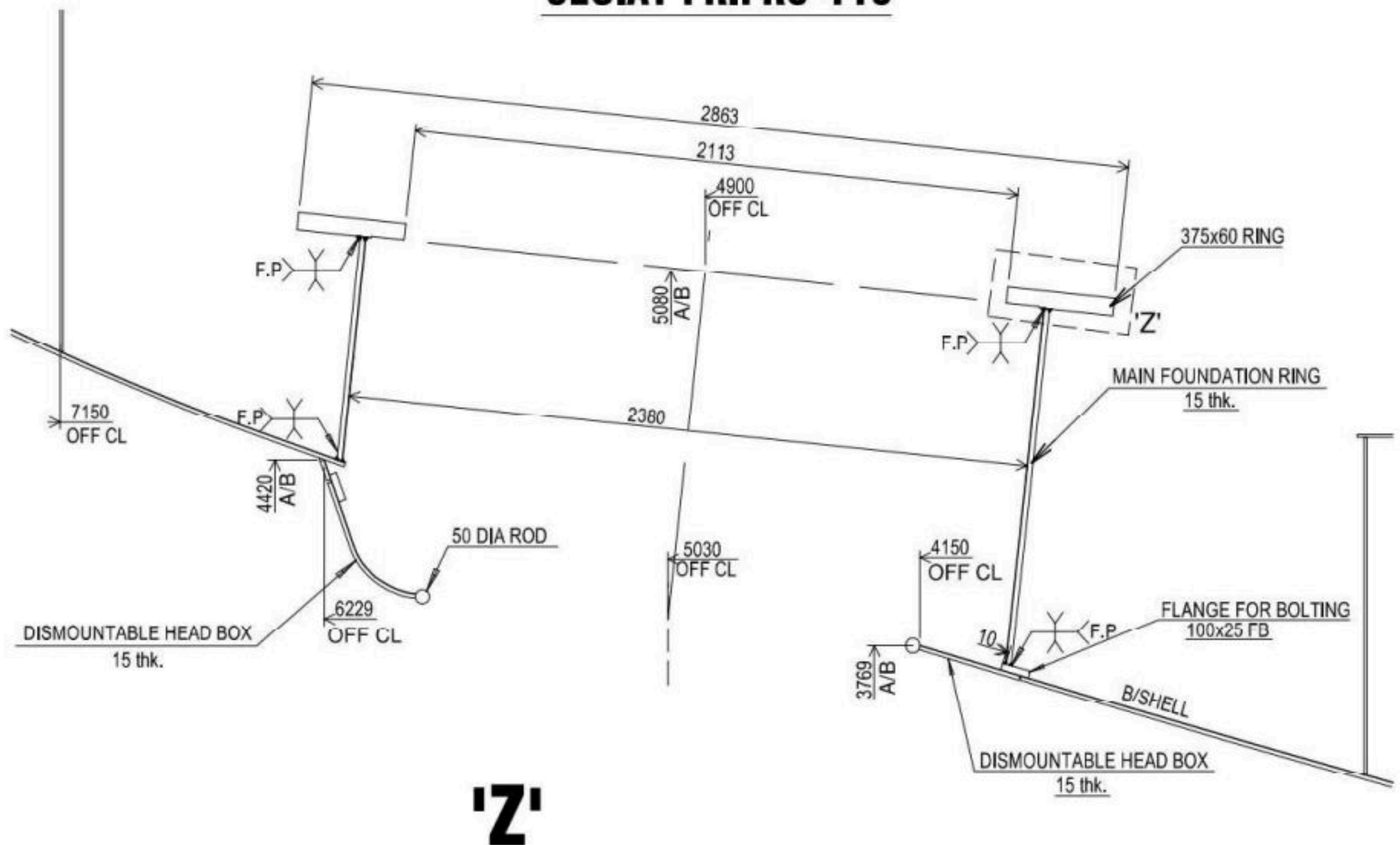

**'Z'**

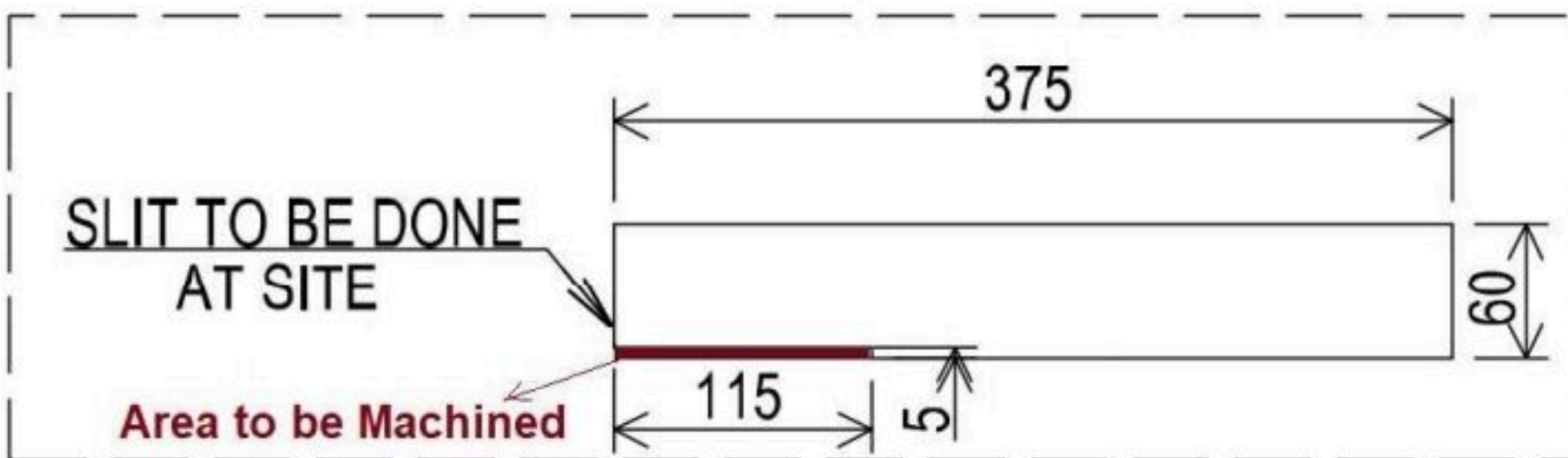

**Notes:**

1. Area to be Machined is highlighted in red in detail 'Z'
2. Surface Roughness of Machined Surface - Ra6.3
3. Flatness Tolerance of Machined Surface -  $\square 1$

1 2 3 4 5 6 7 8

A B C D E F

Frame 6x120x240, prepared for Roxtec insert's RM60x18 or RM120x12. Inserts are yard supply.

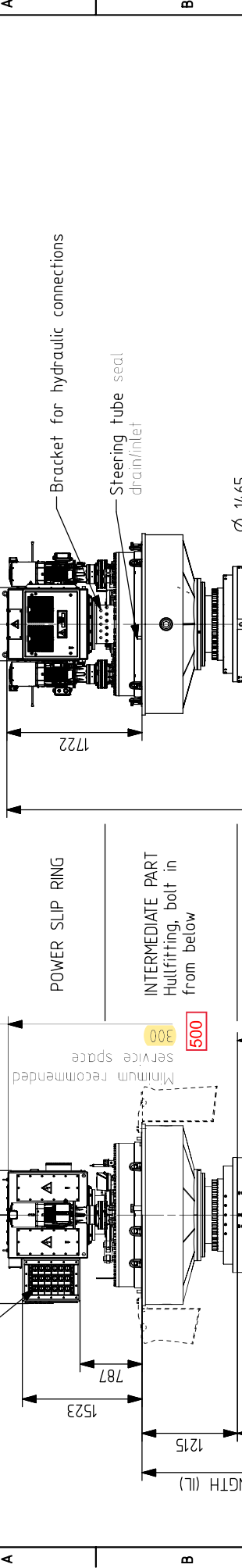

PROPELLER DIAMETER	[mm]	2600
PROPELLER BLADES	[n]	6
INSTALLATION LENGTH (IL)	[mm]	3395 (3595)

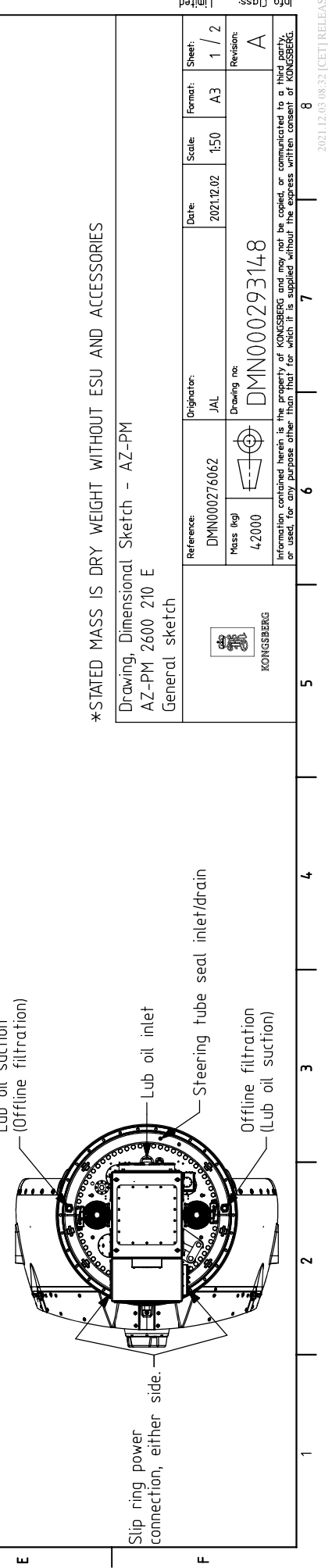
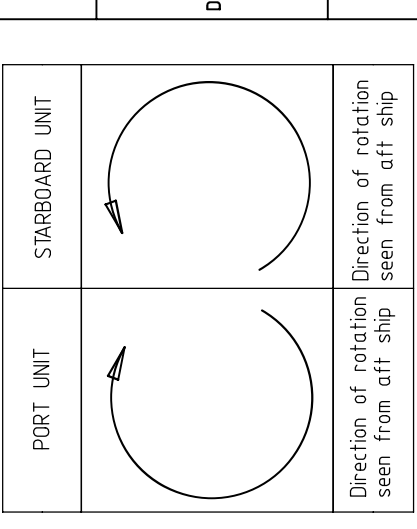

\*STATED MASS IS DRY WEIGHT WITHOUT ESU AND ACCESSORIES

Drawing, Dimensional Sketch - AZ-PM  
AZ-PM 2600 210 E  
General sketch

Reference:	DMN00276062	Origination:	JAL	Date:	2021.12.02	Scale:	1:50	Format:	A3	Sheet:	1 / 2
Mass (kg)	42000	Drawing no:	DMN00293148							Revision:	A

Information contained herein is the property of KONGSBERG and may not be copied, or communicated to a third party, or used, for any purpose other than that for which it is supplied without the express written consent of KONGSBERG.

1 2 3 4 5 6 7 8

A B C D E F

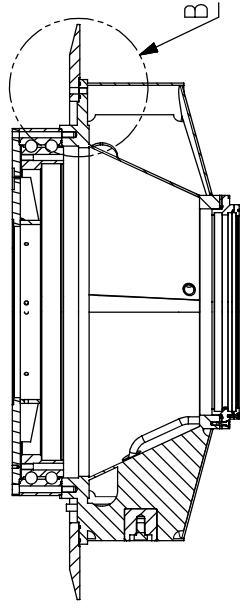

A-A (1:25)

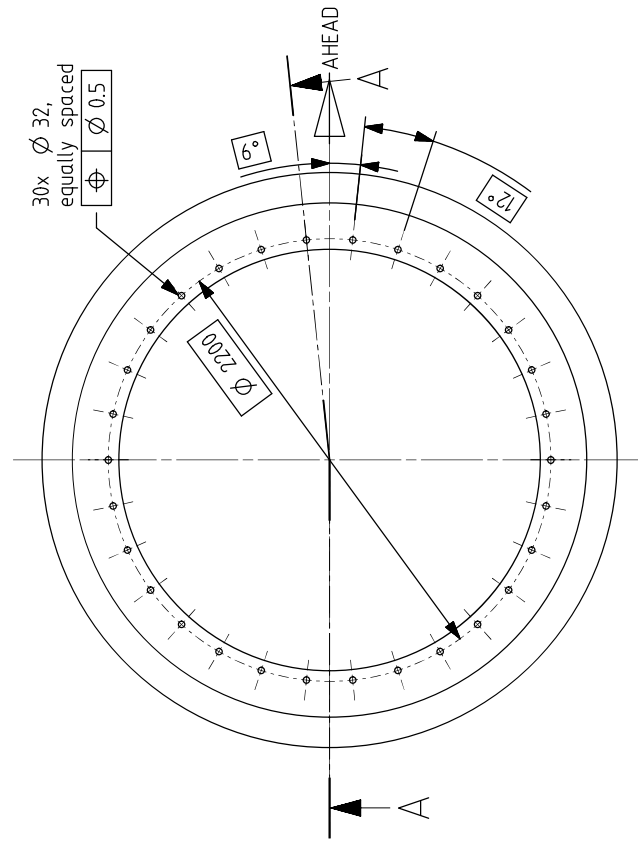

Hole pattern for vessel foundation

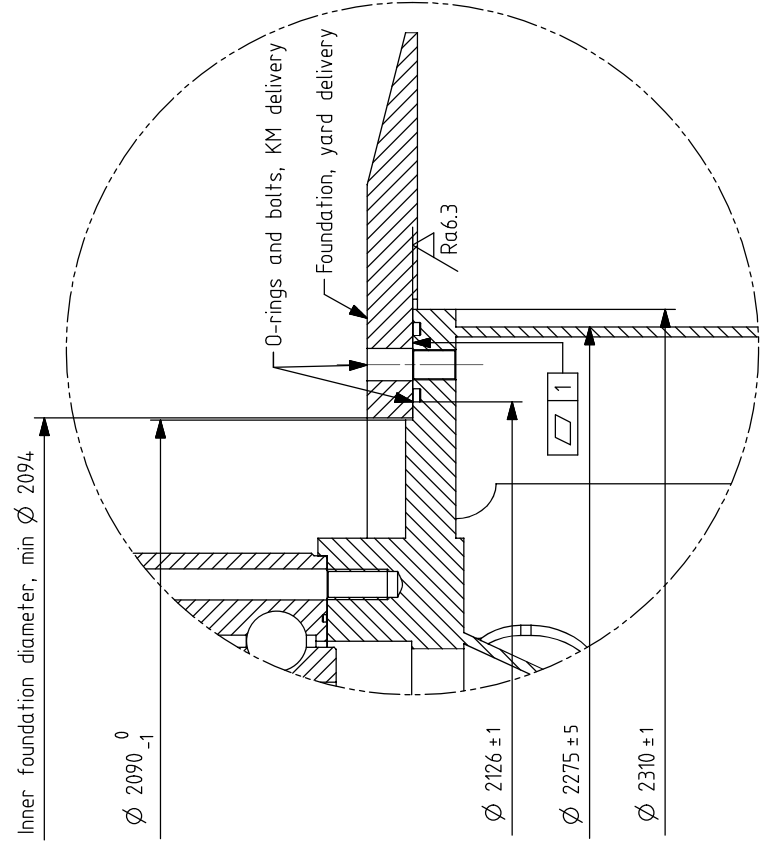

B (1:5)

Drawing, Dimensional Sketch - AZ-PM  
AZ-PM 2600 210 E  
General sketch

Reference:	DMN00276062	Origination:	JAL	Date:	2021.12.02	Scale:	1:25	Format:	A3	Sheet:	2 / 2
Mass (kg)	42000	Drawing no:	DMN000293148	Revision:	A						

Information contained herein is the property of KONGSBERG and may not be copied, or communicated to a third party, or used, for any purpose other than that for which it is supplied without the express written consent of KONGSBERG.